

PROBLEMS OF HOUSING AND PLANNING IN A GROWING URBAN CENTRE:  
A UNIT OF CURRICULUM AND INSTRUCTION  
BASED ON THE THEORIES OF MAURITZ JOHNSON, JR.  
AND THE CRITERIA OF THE CANADA STUDIES FOUNDATION

**CENTRE FOR NEWFOUNDLAND STUDIES**

**TOTAL OF 10 PAGES ONLY  
MAY BE XEROXED**

**(Without Author's Permission)**

FREDERICK T. BUTLER



C.1

101789

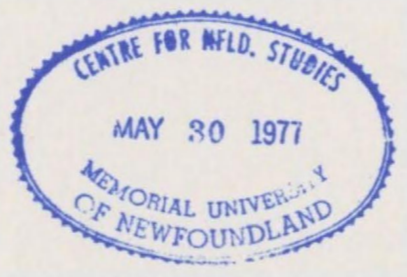

1875





PROBLEMS OF HOUSING AND PLANNING IN A GROWING URBAN CENTRE:

A UNIT OF CURRICULUM AND INSTRUCTION

BASED ON THE THEORIES OF MAURITZ JOHNSON, JR.

AND THE CRITERIA OF THE CANADA STUDIES FOUNDATION



BY

Frederick T. Butler

A Thesis submitted in partial fulfillment of  
the requirements for the degree of  
Master of Education

Department of Curriculum and Instruction

Memorial University of Newfoundland

Fall, 1975

St. John's

Newfoundland

## Abstract

The major purpose of this study was to develop a unit of curriculum and instruction based on the theories of Mauritz Johnson, Jr. (1967, 1969) and the criteria of the Canada Studies Foundation.

The unit developed, "Problems of housing and planning in a growing urban centre," is part of an interdisciplinary, multi-media kit which is presently being developed by the St. John's team of Project Atlantic Canada. The kit includes student booklets, teacher's guidebook, slide tape production, wall charts and aerial photographs. The writer participated in the development and selection of many of the materials in the kit.

The unit was formatively evaluated at several stages of the developmental process. Materials were appraised by experts in social studies education and audio visual education to establish the validity and teachability of the unit. Guiding questions (Anderson, 1972; Hodgetts, Tomkins, and Bowles, 1974) for the development of units of curriculum and instruction were employed throughout the formative evaluation to ensure adherence to Johnson's theories and the criteria of the Canada Studies Foundation. Fry's readability formula (Fry, 1968) was applied to determine the reading level of the student narrative. Finally, the unit was field tested in six classrooms. The major conclusions which result from this study are as follows:



1. Johnson's theories (1967, 1968) can be used as a theoretical framework on which to build a unit of curriculum and instruction.
2. The criteria of the Canada Studies Foundation can be incorporated into the development of a unit of curriculum and instruction.
3. The theories of Mauritz Johnson, Jr., used in conjunction with the criteria of the Canada Studies Foundation can provide a useful framework for involvement in curriculum development by an inexperienced developer.
4. The "Guiding questions to aid in the development of curriculum and instruction units (Anderson, 1972)" can aid in the formative evaluation of units of curriculum and instruction.
5. The "Guiding questions for developing Canada studies curricula (Hodgetts, Tomkins, and Bowles, 1974)" can be useful in the evaluation process of curriculum development.
6. The unit developed can be successfully taught to junior high school students.
7. Both students and teachers enjoyed and understood the materials and activities of the unit developed.
8. Both students and teachers considered the materials and activities used throughout the unit developed to be appropriate

9. The unit developed can be used to supplement existing social studies programs in Canada studies.



## Acknowledgements

A sincere thank you is extended to the many people who aided in the preparation of this study. In particular, a special thank you goes to Mr. M. Brewster, the supervisor, and the other members of the committee, Dr. R. M. Anderson and Dr. J. A. Muir, for the constructive criticism and encouragement which was provided throughout the course of this study. Further, much gratitude is expressed to the St. John's team of Project Atlantic Canada in offering the opportunity for the writer to become actively involved in curriculum development. Finally, the writer wishes to thank his parents and Carol without whose love, confidence, and understanding, this thesis could not have been written.

## Table of Contents

	<u>Page</u>
1. Introduction	
Purpose	1
Background Information	1
Problem	5
Major questions	6
Minor questions	7
Limitations	7
Definition of Terms	7
Summary	9
2. Review of Related Literature	
Introduction	10
Johnson's Theories	10
Curriculum development system	12
The instructional system	14
Instructional plan	14
The execution	15
Evaluation	16
The Criteria of the Canada Studies Foundation	18
The Unit Approach in Curriculum and Instructional Development	24
Summary	26
3. Methodology	

	<u>Page</u>
Introduction	27
The Curriculum	27
Source of the curriculum	27
The general intended learning outcomes	30
The specific intended learning outcomes	34
The Instructional Plan	37
The instrumental content	37
Student text	37
Teacher's guidebook	39
Audio-visual materials	39
Teaching strategies	42
Evaluation Procedure	44
Summary	46
4. Formative Evaluation	
Verification by Outside Experts	47
Application of the Guiding Questions	51
Application of Fry's Readability Formula	55
Field Testing	59
Teacher questionnaire for lesson	60
Student questionnaire for lesson	63
Summary	71
5. Summary, Conclusions, and Recommendations	
Summary	73



	<u>Page</u>
Conclusions	74
Recommendations	75
References	77
Appendices	
Appendix A: Student Narrative	81
Appendix B: Teacher's Guidebook	99
Appendix C: Rating Scales for Validation of Programs (RSVP)	122
Appendix D: Guiding Questions to Aid in the Development of Curriculum and Instruction Units	148
Appendix E: Teacher Questionnaire for Lesson (TEQL)	153
Appendix F: Student Questionnaire for Lesson (STQL)	160
Appendix G: Tables and Graphs of Results of Student Questionnaire	171



## List of Figures

		<u>Page</u>
Figure 1	Curriculum Evaluation Model	17
Figure 2	Fry's Readability Graph	58
Figure 3	STQL Miscouche Regional High, Prince Edward Island	173
Figure 4	STQL Vineland Public School, Ontario	175

## List of Tables

		<u>Page</u>
Table 1	STQL Miscouche Regional High School	172
Table 2	STQL Vineland Public School	174

## CHAPTER 1

### Introduction

#### Purpose

The purpose of this thesis is to describe how a unit of curriculum and instruction was developed based on the theories of Mauritz Johnson, Jr., and the criteria of the Canada Studies Foundation.

#### Background Information

The publication of What Culture? What Heritage? revealed that by 1968, "Canadian studies in our elementary and secondary schools had stagnated (Hodgetts, 1968, p. 7)." This statement was reaffirmed by Massey (1971) in a report on Canadian studies in Canadian schools. These reports of the deplorable conditions which dominated the Canadian social studies educational scene made teachers aware that what was needed throughout the nation was a revitalized approach toward the implementation of Canada studies programs. Teacher initiative in curriculum development has been one such attempt to enliven the state of Canada studies and since its inception, has become "a burgeoning phenomenon in Canada (Anderson and Roald, 1973, p. 1)." Evidence of the increased participation in curriculum development by teachers is the many teachers who are directly involved in developing curriculum in Canada studies as members of project teams of the Canada Studies Foundation. Through a Canada Studies Foundation project team, a teacher can partake in designing



curriculum that reflects the major organizing principle of the Canada Studies Foundation, that of "continuing Canadian concerns" (Tomkins, 1972). Each of the projects, regardless of the topic chosen or the title, has the following features in common:

- a. The projects are teacher-based, thereby providing an immediate impact in the classroom and involving students from the outset.
- b. The projects have academic and other expert consultants to ensure that the materials produced are academically and pedagogically sound and to encourage close co-operation between classroom teachers and people at other levels of education.
- c. The projects have a high degree of inter-regional co-operation. A substantial part of the Foundation's budget is allocated to provide opportunities for teachers from different regions and provinces to meet regularly and work together on classroom materials and methods related to Canadian questions of shared interest. This inter-provincial and inter-regional kind of co-operation is an important aspect of all projects but is a special feature of the Laurentian Projects which bridge not only regional, but cultural and linguistic boundaries. Since its inception, the Foundation has sponsored, either during the regular school year or during the summer holidays, 190 of these inter-regional meetings.
- d. The projects have generated local support within their regions in cash, services and facilities from school boards, universities, teachers, federations, and other organizations. It is estimated that the value of this regional support, as distinct from grants made to projects by the Foundation, will exceed \$500,000 by June, 1975.
- e. The projects are engaged in the development of multi-media classroom materials organized into units of work of three to eight weeks duration that can be slotted into existing curricula. Interprovincial co-operation means that regional, ethnic, and other group differences and similarities of viewpoint on any Canadian concern are built into the materials



from the outset, thus ensuring a comparative approach to the various issues under consideration, (Canada Studies Foundation Annual Report, 1972).

Yet the above commonalities do not interfere with each project's individuality. The Canada Studies Foundation has chosen the following four major areas of continuing Canadian concerns which are evident in all parts of Canadian society.

1. The relations between the various ethnic and linguistic groups in Canadian society.
2. The exposed nature of Canadian society.
3. The regionally divided nature of Canadian society.
4. The impact of industrialization and technological change on Canadian society, (Canada Studies Foundation, Memorandum #6, pp. 11-12).

From the four listed major areas, each team chose one and then commenced the process of developing a topic which could easily be researched in its own local area. According to Anderson (1973), the Canada Studies Foundation director for Project Atlantic Canada, Newfoundland and Labrador, when work began on developing units by an individual team, it then became the responsibility of the members to develop materials based on the following criteria:

1. A series of curriculum and instruction units developed and evaluated largely by practicing teachers.

2. Materials developed from a regional viewpoint.
3. Materials of national significance.
4. Materials interchangeable across Canada.
5. Materials which encompass all grade levels.
6. Materials to be inserted as a unit of an existing course, or combined into a full course.
7. Materials that are interdisciplinary in nature.
8. Printed materials that are supported by multi-media materials.
9. Materials that deal with controversial issues.
10. Materials that present differing points of view.
11. Materials that contain inquiry-oriented and expository materials.
12. Materials that stress empathy for all individuals and multiple loyalties, (Anderson, 1973, p. 13).

The Canada Studies Foundation, a funding organization for the development of curriculum units in Canada studies, was established in 1970. The Foundation has three major divisions: Project Canada West, The Laurentian Projects, and Project Atlantic Canada. In June, 1974, the writer was approached by the chairman of the St. John's team of Project Atlantic Canada and offered the opportunity to become an active curriculum developer on that team. Through consultation with Dr. R. M. Anderson of Memorial University of



Newfoundland and consideration of the offer by the St. John's team, the writer accepted and immediately commenced research on the topic, "Culture in transition: Problems of a changing lifestyle." After several months of research on the original topic, the team members determined that the most efficient way to approach the development of curriculum on "Culture in transition: Problems of a changing lifestyle," was to divide the major topic into several sub-units. The sub-unit which the writer decided to research was "Problems of housing and planning in a growing urban centre." It was concluded by the writer and the project team that the topic could be investigated and designed to achieve the goals of the Canada Studies Foundation which are implied in the above-stated criteria.

### Problem

Two graduate students at Memorial University have devised units of curriculum and instruction in social studies. Cowan (1973) produced a unit based solely on the theories of Mauritz Johnson, Jr. (1967, 1969). Fagan (1974), however, did construct a unit based on the theories of Mauritz Johnson, Jr., and the criteria of the Canada studies Foundation. It is this researcher's opinion that

6

Fagan (1974) placed her major emphasis on Johnson's theories. Although an adequate application of the Canada Studies Foundation criteria was evident in the production of the unit, "Resource-based one industry towns;" (Fagan, 1974), there seemed to be not as great a discussion in depth of the application of the Canada Studies Foundation criteria while the employment of Johnson's theories was obvious. Furthermore, additional published criteria have become available since Fagan's report. Finally, Fagan (1974) created a unit of curriculum and instruction primarily for use with high school students. Hence, it was resolved by this writer that as a member of a Canada Studies Foundation team, it would be possible to further test Fagan's findings and at the same time investigate the utilization of the Canada Studies Foundation criteria in the construction of a unit of curriculum and instruction for use primarily with junior high school students. The main problem, therefore, of this study is to answer several questions concerning the development of the unit, "Problems of housing and planning in a growing urban centre."

#### Major questions

- a. Can Johnson's theories be used as the theoretical framework on which to build a unit of curriculum and instruction on problems of housing and planning in a growing urban community?



- b. Can the criteria of the Canada Studies Foundation be incorporated into the development of a unit of curriculum and instruction on problems of housing and planning in a growing urban community?

Minor questions.

- a. Can this unit be successfully taught to junior high school students?
- b. Can the intended learning outcomes for knowledge, techniques, values, and attitudes be achieved?

Limitations

- a. The unit is limited to problems of housing and planning in a growing urban centre.
- b. The unit will be suitable for students who have achieved a minimum reading level of grade seven.
- c. Sources of non-disciplined knowledge will be the major sources of reference.

Definition of Terms

The definitions are based on the theories of Johnson (1967, 1969).

cultural content - the disciplined and non-disciplined knowledge from which a curriculum may be developed.

disciplined knowledge - knowledge that is the result of deliberate inquiry and is formally structured.

non-disciplined knowledge - knowledge that is the result of ordinary experiences and is informally structured. Examples of non-disciplined knowledge are found in newspapers, magazine articles, interviews, and periodicals.

curriculum - a structured series of intended learning outcomes.

instructional plan - a model of instruction that is comprehensive enough to encompass all possible instructional situations. It should not, however, include every instance in which learning occurs or studying takes place.

instrumental content - the object, event, or action with which the students transact affectively, cognitively and conatively. It is the content not intended to be learned, but to facilitate learning.

instructional content - the intended learning outcomes and the instrumental content taken together.

teaching strategies - the way in which teaching techniques are used with the developed unit.

instruction - the interaction between the student and the classroom display and the interaction between the student and the teacher.

formative evaluation - evaluation conducted throughout the developmental process.

unit - will refer to the unit titled, "Problems of housing and planning in a growing urban community." junior high school - grades seven, eight, and nine in Newfoundland schools.

#### Summary

The purpose of this study was to develop a unit of curriculum and instruction based on the theories of Mauritz Johnson, Jr. and the criteria of the Canada Studies Foundation. The title of the unit is "Problems of housing and planning in a growing urban centre." This chapter discussed the background of the study and provided a justification for the study. Unfamiliar terms which will appear later in the study were defined.

Succeeding chapters will include discussions of the methodology employed in the development of the unit, the application of Johnson's theories and the criteria of the Canada Studies Foundation to the development of the unit, the utilization of formative evaluation procedures, and the provision of conclusions and recommendations which result from this study.



## CHAPTER 2

### Review of Related Literature

#### Introduction

The review of the related literature for the development of the unit of curriculum and instruction, "Problems of housing and planning in a growing urban centre," is divided into three sections: (1) Johnson's theories, (2) the criteria of the Canada Studies Foundation, and (3) the unit approach in curriculum and instructional development.

#### Johnson's Theories

According to Cowan (1973) and Fagan (1974), a firm theoretical base is required for the adequate development of a unit of curriculum and instruction. Both of these writers have agreed that Johnson's theories for curriculum and instruction development can provide a developer with a workable theory which is easily applied when developing units in curriculum and instruction. In addition, the St. John's team of Project Atlantic Canada had already commenced using Johnson's theories in the process of developing units of curriculum and instruction on the topic, "Culture in transition: Problems of a changing lifestyle," when the writer joined the team. For these reasons Johnson's theories were chosen as the theoretical framework for the development of the unit, "Problems of housing and

planning in a growing urban centre."

Various attempts have been made by curriculum theorists in trying to define the term curriculum. Doll (1964) views curriculum as "involving what happens in classrooms, gymnasiums, hallways, cafeteria, and school activities - anywhere the children are under the direction and guidance of the school (p. 15)." Others like Saylor and Alexander (1966) see curriculum "as encompassing all learning opportunities provided by the school (p. 5)." Taba (1962), while expanding Tyler's (1950) model for curriculum development, defined curriculum in the following way:

Curriculum usually contains a statement of aims and objectives. It indicates some selection and organization of content; it either implies or manifests certain patterns of learning and teaching; and, finally, it includes a program of evaluation of the outcomes (p. 10).

A close look at each of the above definitions will reveal, however, that in many cases curriculum is defined with some references to "planned learning experiences." Other writers like Short and Marconnit (1967), Richmond (1971), Wright, et. al., (1971), and Lavatelli, et. al., (1972) have expressed a similar point of view in their definitions of curriculum. According to Johnson (1967) any definition related to planned learning experiences "is unsatisfactory, however, if curriculum is to be distinguished from instruction (p. 4)."

Gagne (1967) makes the following statement in his definition of curriculum:

Curriculum is a sequential development of content units arranged in such a way that the learning of each unit may be accomplished as a single act, provided the capabilities described by specific prior units (in the sequence) have already been mastered by the students, (p. 23).

The above definition is more indicative of how Johnson defines curriculum. Johnson (1967, 1969) defines curriculum as a structured series of intended learning outcomes. This is one of the outstanding features of Johnson's theories. By defining curriculum as a structured series of intended learning outcomes, he is distinguishing curriculum from instruction in his model for curriculum and instruction development. Unlike MacDonald who sees curriculum and instruction as separate concepts that overlap to some extent (Johnson, 1967, p. 3) and Maccia who sees curriculum not as a system but as instructional content (Johnson, 1967, p. 3), Johnson (1967) views the curriculum "as an output of a curriculum development system and an input of an instructional system (p. 7)."

#### Curriculum development system

According to Johnson (1969), "it is useful to think of curriculum development as occurring in two phases (p. 118)." Phase one is a selection from the cultural reservoir of a



curriculum matrix. Phase two involves a selection of a curriculum from this matrix for a particular program or unit.

The cultural reservoir for phase one is the source for the curriculum. It consists of both disciplined and non-disciplined knowledge. As Johnson (1967) states: "the only possible source... is the total available culture (p. 6)." Selection from this cultural reservoir is essential in the development of the curriculum matrix or master curriculum. The curriculum matrix consists of all the teachable cultural content which has been selected and structured from the areas of disciplined and non-disciplined knowledge. It is Johnson's opinion that the best available scheme for classifying curriculum items is the taxonomy of educational objectives (Bloom, et. al., 1956; Krathwohl, et. al., 1964).

The further selection from the curriculum matrix results in the curriculum, the structured series of intended learning outcomes for a specific unit of work. These intended learning outcomes are selected for a particular purpose. Curriculum in this phase prescribes the results of instruction; it does not prescribe the means. The curriculum is concerned with the ends. In other words, as Johnson (1967) states, "curriculum indicates what is to be learned, not why it should be learned (p. 4)."

### The instructional system

Johnson (1969) emphasizes "a definition or model of instruction must be comprehensive enough to encompass all possible instructional situations (p. 123)." In direct disagreement with writers like Doll (1964), and Short and Marconit (1968), Johnson points out that instruction should not include every instance in which learning occurs or studying takes place. According to his definition, there must be "an intent on the part of some agent or agency to bring about learning directly or indirectly (p. 124)." Unlike Taba (1962), who propounds that learning results in an observable change in behavior, Johnson (1968) states, "learning does not always result in a change of behavior, nor does a change of behavior always result from learning (p. 124)." Johnson's instructional system consists of three major components which include the instructional plan, the execution, and evaluation.

### Instructional plan

Earlier in this paper it was stated that curriculum is the output of the curriculum development system and the input of the instructional system. Johnson (1969) points out "primarily, curriculum influences instruction through the mediation of an instructional plan (p. 128)." This plan would include the intended learning outcomes selected

from the curriculum matrix. Further, the plan would include the selection of the instrumental content which is intended to facilitate the learning, but which is not to be learned. In addition, when developing the instructional plan, it is recommended that a selection of teaching strategies be considered.

The instructional plans may take many forms. They may be instructional programs in which even the detailed central tactics are specified; they may take the form of instructional packages, in which display media are provided and control strategy is prescribed; or instructional planning may be done by the instructors themselves (Johnson, 1969). In the case of the unit, "Problems of housing and planning in a growing urban centre," the display media have been provided. The control strategy, however, is not prescribed but is suggested. This is to enable the teacher of the unit to take an active part in the instructional planning of the unit.

#### The execution

The execution of the instructional plan depends on the learning activities and the instrumental content which the individual teacher has incorporated into the unit plans to achieve the intended learning outcomes. The execution or instruction "consists of two sets of interactions (Johnson, 1967, p. 8)." One is the transaction between the student and



the display. The second is the interpersonal interaction between the teacher and the students.

### Evaluation

In his 1969 paper, Johnson presented a seven step model for evaluation. He has since refined this to a five step process for curriculum evaluation. The five steps from Johnson (1974) are represented diagrammatically in Figure 1. A close look at the model will reveal that evaluation of curriculum is prompted only when a curriculum is not being satisfactorily achieved, and then only when broader educational results are unsatisfactory. Johnson (1974) points out that evaluation thus prompted involves a review both of the curriculum and the curriculum developmental process.

Johnson (1974) continues to explicate that when the learning outcomes are unsatisfactory, it is the execution (instruction), not the curriculum, which is first investigated in the evaluation procedure. Either the instructional plan has not been adequately implemented in the process of instruction, or the plans themselves are inadequate as a means of achieving the intended learning outcomes.

Finally, in his discussion of evaluation, Johnson (1974) expresses the opinion, "it should be apparent that to the extent that appropriate procedures for evaluating the educational results are not available, the summative

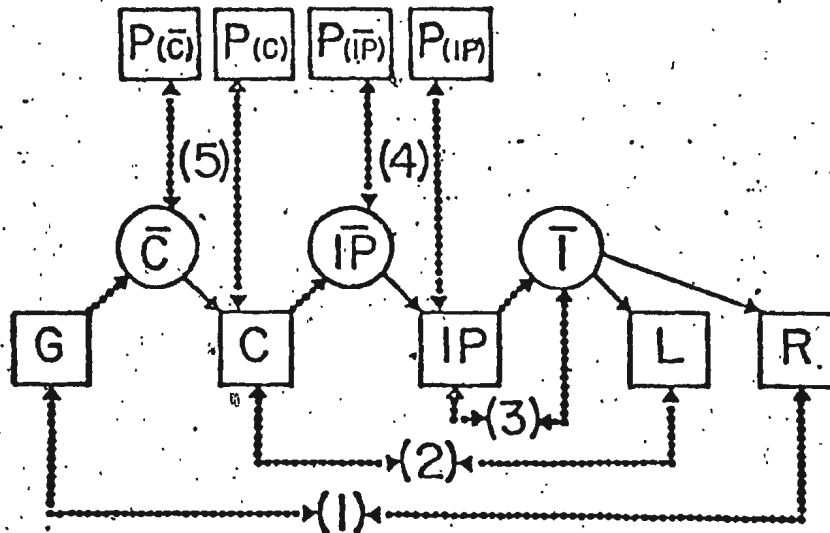

Fig. 1. "Curriculum evaluation" finds meaning within a five-step process. Curriculum evaluation (5) is called for when (1) is unsatisfactory. Instructional plans and planning need evaluation (4) when (1) and (2) are both unsatisfactory, but (3) is satisfactory (Johnson, 1974, p. 381).

#### Legend

- C - curriculum (intended learning outcomes)
- IP - instructional plan
- L - product of instruction through learning process (actual learning outcomes)
- R - educational results (product of instruction through developmental process of integrating)
- G - educational goals (intended educational products or results)
- $\bar{C}$  - process of curriculum development
- $\bar{IP}$  - process of instructional planning
- $\bar{I}$  - process of instruction (implementation of IP)
- $P(\bar{C})$  - plan for the process of curriculum development
- $P(C)$  - plan for the curriculum
- $P(\bar{IP})$  - plan for the process of instructional planning
- $P(IP)$  - plan for the instructional plan

evaluation of curriculum is impossible or at least necessarily inadequate (p. 381)." He goes on to mention that no amount of evidence that curriculum is being achieved will tell whether the curriculum should be achieved. He states, however, "such evidence shows that the current curriculum is achievable, and this is worth knowing (Johnson, 1974, p. 381)."

In this section a brief introduction to the theories of Mauritz Johnson, Jr., for the development of units in curriculum and instruction was presented. Johnson's model was chosen for its unique separation of curriculum and instruction into two developmental systems, (1) the curriculum development system, and (2) the instructional development system. Johnson's theories played a vital role in providing a workable theoretical framework for the development of the unit of curriculum and instruction, "Problems of housing and planning in a growing urban centre." For a further discussion of Johnson's theories the reader is referred to Cowan (1973) and Fagan (1974).

#### The Criteria of The Canada Studies Foundation

The history, background, and an introduction to the criteria of the Canada Studies Foundation (C.S.F.) were presented in Chapter One. In this section, however, the discussion of C.S.F. criteria will be expanded.

Johnson (1967) stated that in the selection of

intended learning outcomes "that whatever criteria are used be made explicit (p. 6)." An explicit statement of the criteria of the C.S.F. presented a problem to the developer of the unit "Problems of housing and planning in a growing urban centre." In the majority of cases in C.S.F. publications the criteria for developing curriculum are implied rather than explicated. The only definite criterion which is presented in the literature prior to 1974 is that all C.S.F. projects must have one major goal, "to encourage a greater degree of national understanding in the minds of students (Hodgetts, 1974, p. 1)."

Probably one of the best attempts at expanding on C.S.F. criteria was that of Hodgetts (1974) when he implied that the following points be considered in the development of Canada studies programs:

1. they should be consciously designed to give our young people a better understanding of their total Canadian environment;
2. they should be based on specific, clearly defined kinds of knowledge that will indeed help students to raise their perspectives from the local and regional to the wider Canadian scene;
3. they should give our young people a chance to make meaning from the present chaos. For example, students should be able to analyze change more skilfully and to recognize that trend is not destiny;
4. they should be based on knowledge of both the social and cultural environments which should be the starting point in any program of study and the basis for all good teaching;



5. they should be organized around the principal of continuing Canadian concerns and developed under one of the following characteristics that help determine the nature of Canadian society:
  - (a) Canada is a large, regionally divided and diverse country;
  - (b) Canada is a highly industrialized and technologically advanced country;
  - (c) Canada is an urbanized country, rapidly becoming a nation of city dwellers;
  - (d) Canada is a multi-ethnic country with two predominant linguistic groups;
  - (e) Canada is an exposed country, open to a multitude of external, cultural, economic, and political influences;
  - (f) Canada is a country with a unique northern geographic location;
  - (g) Canada is a country that has previously ignored, to its detriment, the significance of its past; the work of its historians and the contribution of its artists, poets, novelists, and other creative people who have had much to say emotionally and imaginatively about Canada;
6. they should be developed around the great issues, the problems, the values, the striving for common social purposes that Canadian society deems worthy of the continuing concerns of its members;
7. they should help our students to understand that as Canadians they share many vital concerns;
8. they should point out that the differences from coast to coast, on which we tend to dwell too much, are less significant when compared to the challenges faced together;
9. they should help students realize that it is important for people in one part of the country to know how people from other parts react to these problems; (Hodgetts, 1974, pp. 1-6).

A more explicit attempt at establishing C.S.F. criteria was finally achieved by Hodgetts and Tomkins, directors of the C.S.F., and Bowles, associate director. Hodgetts, Tomkins, and Bowles (1974) presented five series of guiding questions for developing Canada Studies curricula. In these questions which cover the major aspects of curriculum development, C.S.F. criteria are naturally inherent. The five series of questions are as follows:

#### Series 1

- (a) What are the main features that help to determine the nature of Canadian society?
- (b) To what extent do these features or characteristics generate a range of national problems that are of continuing concern to Canadians?
- (c) What is the role of the various disciplines in studying Continuing Canadian Concerns?
- (d) What sources besides the conventional disciplines are available in using the Continuing Canadian Concerns approach?
- (e) How can local studies be used to help students understand Canada?
- (f) How do Continuing Canadian Concerns lend meaning to local or regional studies?
- (g) What means best ensure that a comparative element is built into work in Canada studies?

#### Series 2

- (a) Why is a consideration of goals such as "national understanding," "mutual awareness," "identity," and "citizenship," and the meaning of these, fundamental

to the development of Canada studies programs?

- (b) What are the guidelines for Canada Studies set out in your provincial and local jurisdictions? What are some of the problems and possibilities inherent (sic) in these?
- (c) What are the implications for Canada Studies goals of the socio-economic and cultural characteristics (including ideologies, beliefs, and values) of the local community and student body?
- (d) How stable and dependable in the long range are the suggested goals of any Canada Studies curriculum likely to be, given the rate of change at the local and societal levels?

### Series 3

- (a) What knowledge/skill objectives will contribute to the overall goal of Canada Studies?
- (b) What value/attitude objectives will contribute to these goals?
- (c) How can unintended learning outcomes be identified and assessed?
- (d) What major criteria should be used for selecting content for Canada Studies courses?
- (e) Which principle of organization of Canada Studies, i.e., disciplinary, multi-disciplinary, interdisciplinary, "issues" or "problems" seems best for your setting? Why?

### Series 4

- (a) In terms of goal and course objectives, how would you justify inclusion of any particular topic in a Canada Studies unit of work?
- (b) What themes or main ideas illustrative of Continuing Canadian Concerns could be taught by means of the chosen topic?

- (c) What are some examples of knowledge objectives relevant to the topic chosen in (a) or (b)?
- (d) State some examples of skill objectives (inquiry, human relations, valuing and data handling skills).
- (e) State some examples of value/attitude objectives relevant to the topic chosen in (a) or (b).

#### Series 5

- (a) What outside academic and pedagogical support are teachers likely to need to engage in effective curriculum development work in Canada Studies? How should such support be provided?
- (b) What incentives and resources are likely to be necessary if teachers are to engage in effective Canada Studies work? What are the obstacles to the provision of these?
- (c) What are some examples of materials, other resources, and strategies consistent with the objectives of the unit chosen in Series 4 above and likely to assist achievement of the objectives? What are some examples of appropriate starting points for the chosen unit?
- (d) What purposes should evaluation of Canada Studies work serve and what forms should it take? What should count as evidence that the objectives have been attained?
- (e) What techniques are available and practical to ensure that a comparative element is built into the work of teachers in Canada Studies? How can the range of inter-regional co-operation in Canada Studies best be extended (Hodgetts, Tomkins, and Bowles, 1974, pp. 16-20)?

The above stated questions can be used to facilitate the development of units of curriculum and instruction. These questions, in conjunction with the C.S.F. criteria as outlined by Anderson (1973) and the rationale for Canada



Studies (Hodgetts, 1974), were used to ensure adherence to the criteria of the C.S.F. throughout the development and formative evaluation of the unit, "Problems of housing and planning in a growing urban centre."

The Unit Approach in Curriculum  
and Instructional Development

Historically, the use of the unit method can be traced from the writings of Herbert and his followers through McMurry, Dewey, Kilpatrick, Morrison and others (Wilson, 1963). The unit method, according to Joyce (1974), "was a child of the Progressive Era, especially the first forty years of the twentieth century (p. 252)." During this era, emphasis switched from the learning of subject matter to the development of the child. With the switch in emphasis the unit method developed. By the early 1950's the unit method was praised for its substantial contributions to the progress of education. Preston (1950) lauded the unit method and attributed its success to several factors:

1. it (the unit method) is flexible;
2. it (the unit method) conforms to the psychology of childhood;
3. it (the unit method) yields superior learning; (p. 75) .

The prominence of the unit method resulted in many attempts to establish a procedure to be followed in a unit approach. One group of educators: Hanna, Porter, and Hagaman (1955),

suggested a procedure which could be followed for the unit approach. The approach, revised by Hanna, Porter, and Hagaman (1966), was basically as follows:

1. make statements of objectives or anticipated outcomes of the proposed unit;
2. select and organize the content for the unit;
3. suggest activities to implement instruction;
4. provide suggestions for evaluation of the unit.

Other educators, (Taba, 1962; Darrow, 1964; Joyce, 1965; Meussig, 1965; Jarolimek, 1967; Michaelis, 1967; Hill, 1970; Kenworthy, 1970), recommended the unit approach as an effective means of organizing curriculum.

The unit approach has been highly extolled by the Canada Studies Foundation (C.S.F.) as very useful in developing curriculum in Canada Studies (Hodgetts, Tomkins and Bowles, 1974). According to Hodgetts (1974) in using the unit approach for continuing Canadian concerns "the focus is still likely to be historical but ideas from other disciplines are also likely to be significant (p. 10)." This provides a great deal of flexibility in developing the curriculum. It is pointed out by the Canada Studies Foundations that within the unit approach it is possible to determine the intended learning outcomes (the curriculum); develop a suitable instructional plan; suggest possible teaching

strategies; and consider means of evaluating the curriculum (Hodgetts, 1974, p. 11). Most of the prevailing ideas of the unit approach in curriculum development have been incorporated into the unit of curriculum and instruction, "Problems of housing and planning in a growing urban centre."

#### Summary

In this chapter background information on the theories of Mauritz Johnson, Jr., the criteria of the Canada Studies Foundation, and the unit approach in curriculum and instructional development was presented. The next chapter will present the procedure employed in applying Johnson's theories and the Canada Studies Foundation criteria to the development of the unit of curriculum and instruction, "Problems of housing and planning in a growing urban centre."

## CHAPTER 3

### Methodology

#### Introduction

The major purpose of this thesis is to recount the development of a unit of curriculum and instruction based on the theories of Mauritz Johnson, Jr., (1967, 1969) and the criteria of the Canada Studies Foundation. In this chapter an attempt will be made to demonstrate the ways in which Johnson's theories and Canada Studies Foundation criteria were applied to the development of the unit, "Problems of housing and planning in a growing urban centre." This chapter will present discussions of the curriculum, the instructional plan, and the evaluation procedure for the unit developed.

#### The Curriculum

##### Source of the curriculum.

The sources from which both the general and specific intended learning outcomes selected for the unit, "Problems of housing and planning in a growing urban centre," are what Johnson (1967, 1969) refers to as the areas of disciplined and non-disciplined knowledge.

Although history forms the basic discipline in the unit developed, various aspects of the disciplines of sociology,



economics, and geography have been intertwined to provide, as suggested by the Canada Studies Foundation, an interdisciplinary approach to the development of the unit.

Sources of disciplined knowledge from which the information included in the student booklet was gleaned were wide and varied. General histories of Newfoundland (Anspach, 1819; Tocque, 1878; Harvey and Hatton, 1883; Perlin, 1959; Rothney, 1964; Matthews, 1968; Horwood, 1969; Mowatt, 1971) provided a great deal of information which helped place the development of St. John's in historical perspective. The Book of Newfoundland (Smallwood, 1937-1967) was instrumental in supplying the writer with many articles written by contemporary Newfoundlanders on various aspects of municipal growth in the city of St. John's. Finally, statistics published by the Canada Bureau of Statistics gave much needed data concerning population growth and population trends in the city of St. John's.

Since no formal history of problems of housing and planning in St. John's has been written, however, many of the intended learning outcomes for the unit were derived from less formally structured material of an undisciplined nature. Reports and articles which appeared in newspapers such as the Financial Post, the Evening Telegram, and the Daily News were extremely helpful in providing contemporary

cultural content related to problems of housing and planning both on the local scene in St. John's, and on the national scene in Canada. Briefs submitted to the St. John's municipal council and planners by the Newfoundland Historic Trust (1969, 1972), made the developer aware of their stand on urban renewal schemes. Reports by Project Planning Associates (1961, 1966) and Proctor and Redfern, Ltd. (1973) provided information about various urban renewal schemes which have been undertaken in the city of St. John's. Plan 91 (1972), the proposed twenty year master plan for the city of St. John's, was studied. The accounts of Our city in conference compiled by the Memorial University Extension Service (1973) brought out many of the problems which will have to be encountered by the citizens of tomorrow in a rapidly growing urban centre. Finally, discussions with employees of the St. John's municipal council planning office aided the developer in researching the many aspects of town planning which are presented in the curriculum.

Once the source of the teachable cultural content was researched and identified, the curriculum for the unit "Problems of housing and planning in a growing urban centre," was then chosen based on the theme of the Canada Studies Foundation, that

of "continuing Canada concerns." Continuing because as stated by Hodgetts (1974):

The word continuing emphasizes that Canadian concerns worthy of attention in our schools are firmly rooted in the past and can be understood, therefore, only in historical perspective. Continuing also indicates a present and future dimension and the need to develop programs having contemporary relevance (p. 5).

The source of the curriculum which has been stated previously permitted the researcher to obtain and develop materials on problems of housing development and town planning which were constructed from a regional viewpoint but of national significance and interchangeable across Canada. This was basic to the attaining of the criteria of the Canada Studies Foundation through the development of the unit.

The general intended learning outcomes.

The unit, "Problems of housing and planning in a growing urban centre," is one of the components of the St. John's project of Project Atlantic Canada, "Culture in transition: Problems of a changing lifestyle." Very early in the developmental process, the project team members developed a series of general intended learning outcomes which eventually became the curriculum matrix or master curriculum for the project. Those general intended learning outcomes were developed considering (1) the needs of the students, and (2) the improvement of the present

curriculum. The rationale governing the selection and organization of these general intended learning outcomes is presented in the teacher's guidebook, Appendix B, page 99 of this thesis. The general intended learning outcomes were constructed under the following three headings which are recommended by the Canada Studies Foundation.

1. Knowledge. Objectives dealing with the cognitive domain to facilitate student recall of factual information and the development of intellectual skills and abilities were compiled (Bloom, 1956).
2. Techniques. Objectives dealing with student techniques to be achieved were developed to enable the teacher to see any changes in student performance which might occur throughout the period of time that the unit is to be taught.
3. Attitudes and Values. Objectives dealing with the affective domain to facilitate student internalization of attitudes and values based on intense emotional problems which are presented in the unit were written (Krathwohl, 1964).

The general intended learning outcomes for the topic, "Culture in transition: Problems of a changing lifestyle,"



were chosen on the basis of their applicability to the criteria of the Canada Studies Foundation which have been stated previously in Chapter One and Chapter Two. These general intended learning outcomes form the curriculum matrix for the St. John's project of Project Atlantic Canada. It was from this master curriculum that the specific intended learning outcomes for the unit, "Problems of housing and planning in a growing urban centre," were selected.

1. Knowledge. The student should be able:

- a) to show an understanding of the concepts of culture, diversity, and transition;
- b) to show an understanding of the meaning of cultural diversity;
- c) to specify some problems of a "cultural transition;"
- d) to show how the lifestyles of the St. John's people are influenced by a multitude of factors;
- e) to make general comparisons between St. John's and other Canadian urban centres;
- f) to make cultural comparisons between urban areas and rural areas;

- g) to trace the history of urban growth in the city of St. John's;
  - h) to recognize the many facets of public controversy to which they are exposed;
  - i) to show how geography plays an important role in urbanization;
  - j) to recognize the trend in Canada towards urbanization.
2. Techniques. The student should be able:
- a) to demonstrate ability to work with primary and secondary sources, if only on a limited scale;
  - b) to gather, organize, and critically analyze data;
  - c) to establish a frame of reference and to work within that frame of reference;
  - d) to demonstrate the ability to work with maps, contour maps, charts, tables, and graphs;
  - e) to demonstrate skill in the use of interviewing techniques;
  - f) to show an ability to utilize a camera effectively in the development of a theme;
  - g) to interpret photographs to find answers to questions;
  - h) to work effectively as a member of a group;
  - i) to dramatize issues of great interest;
  - j) to demonstrate skill in arranging an effective bulletin board display centered around a given theme;

k) to develop a questionnaire and conduct a survey if only on a limited scale;

l) to demonstrate ability to role-play;

m) to debate effectively issues of great controversy.

3. Values and Attitudes. The student should be able:

a) to show understanding for and appreciation of different lifestyles;

b) to make sound judgements regarding the value of modernization and its effects on lifestyles;

c) to show an appreciation for his own culture, and to see it as part of the Canadian identity;

d) to weigh the pros and cons of a problem situation, take a stand and support it;

e) to internalize attitudes dealing with the problem situations presented in the narrative;

f) to express respect and tolerance of diversity.

The specific intended learning outcomes.

The developer, after a careful consideration of the general intended learning outcomes stated above, extracted items from the curriculum matrix which were most appropriate to the development of the unit, "Problems of housing and planning in a growing urban centre." In several instances, items were added to the curriculum matrix to help achieve the specific purposes of this particular unit. In keeping

with the criteria of the Canada Studies Foundation, the specific intended learning outcomes for the unit are as follows:

1. Knowledge. The student should be able:
  - a) to list the advantages and disadvantages of home ownership;
  - b) to list the advantages and disadvantages of rented housing;
  - c) to compare home ownership with rented accommodations;
  - d) to describe nineteenth century St. John's;
  - e) to specify the effects urban renewal schemes have on older sections of a city;
  - f) to enumerate ways in which planning expansion for a city can be implemented;
  - g) to describe plans directly related to the growth of St. John's;
  - h) to give examples of great public controversy in the city of St. John's;
  - i) to compare the housing situation in St. John's with that in other Canadian cities;
  - j) to trace the history of urban growth in St. John's and other Canadian cities;
  - k) to describe the role of planning in a growing urban centre.
2. Techniques. The student should be able:
  - a) to demonstrate skill in interviewing techniques;

- b) to show an ability to research using primary and secondary sources if only on a limited scale;
- c) to demonstrate the ability to work with maps, charts, and tables;
- d) to show an ability to utilize a camera effectively in the development of a theme;
- e) to interpret photographs and slides to find answers to questions;
- f) to work effectively as a member of a group;
- g) to dramatize issues of great public interest;
- h) to demonstrate skill in arranging an effective bulletin board display centered around a given theme;
- i) to develop a questionnaire and conduct a survey if only on a limited scale.

3. Attitudes and Values. The student should be able:

- a) to show an understanding of and an appreciation for the problems involved in town planning;
- b) to make sound judgements regarding the value of modernization;
- c) to understand the problems associated with trying to house a growing population;
- d) to become aware of the importance of a well-thought out plan for expanding a city's limits;
- e) to weigh the pros and cons of a problem situation,

- take a stand, and support it;
- f) to determine whether or not housing should be preserved for its intrinsic historic value;
  - g) to internalize attitudes dealing with the problem situations presented in the narrative.

### The Instructional Plan

#### The instrumental content

The instrumental content was designed to help facilitate the learning. The instrumental content which has been developed to help achieve the intended learning outcomes for the unit consists of a student text, teacher's guidebook, and audio-visual materials. These printed and multi-media materials were devised to attain the criteria of the C.S.F. The components of the unit, "Problems of housing and planning in a growing urban centre," contain inquiry oriented and expository materials, present differing points of view, and deal with controversial issues. For examples, the reader is referred to Appendix A, and Appendix B.

#### Student text

The student text, Appendix A page 81, of this thesis, presents St. John's as an area which is undergoing many changes in the realm of urban development. Systematic town planning and provision of adequate housing are problems



which confront town planners and city inhabitants all across Canada. In this text, the student is presented with the haphazard development which prevailed in the early history of St. John's and he is exposed to the transition which included the initiation of a planning division in the St. John's municipal government. The changes are determined by means of inquiry. The student is also encouraged through the use of comparison studies to compare town planning and housing development in St. John's with his own community and other Canadian cities. The content of the student text is as follows:

1. background information of housing and planning in St. John's;
2. description of nineteenth century St. John's;
3. questioning on twentieth century St. John's;
4. recent developments in town planning in the city of St. John's;
5. controversies related to housing a growing population;
6. suggested activities to bring about an understanding of the terms "culture in transition" and "town planning;"
7. comparative studies;
8. summary.

Pictures are provided throughout the text to stimulate inquiry and to provide visual examples of some of the problems which are discussed throughout the narrative.

The activities suggested throughout the student text are based on the idea that students can learn a great deal by being actively involved in the learning process (Hanna, 1973; Jarolimek, 1967; Joyce, 1965). Each of the activities is designed so that students can discover for themselves various aspects of the problem regardless of the region in which an urban centre is located. It is anticipated that through these activities students will learn to look at the many elements which have to be considered in any public controversy.

#### Teacher's guidebook

The teacher's guidebook, Appendix B, page 99, provides the teacher with the rationale for the St. John's project. Included with this rationale are the general intended learning outcomes for the project, the criteria for the selection of the intended learning outcomes, an outline of the instrumental content for the project, suggested teaching strategies, related activities, a rationale for questioning techniques, background information, and the specific intended learning outcomes for the various components of the project to this date.

#### Audio-visual materials

For many years audio-visual materials have been among the resources for teaching and learning in educational programs

(Kemp, 1968). It is the responsibility of the educator to use these resources effectively. According to Wilkinson (1971), "good teachers have always used whatever available media made their lessons more effective (p. 135)." It was the intent of the developer of the unit of curriculum and instruction, "Problems of housing and planning in a growing urban centre," to produce, as Smith and Nagel (1972) suggested, materials that could be used as an integral part of the unit. These materials provide teachers with a ready supply of media for more effective lessons.

Dale (1969), in a discussion of the use of audio-visual materials in instruction, pointed out their advantages. According to Dale, audio-visual materials can:

1. heighten motivation for learning;
2. provide freshness and variety;
3. appeal to students of varied ability;
4. encourage active participation;
5. give needed reinforcement;
6. widen the range of student experience;
7. assure order and continuity of thought;
8. improve the effectiveness of other materials; (pp. 150-156).

Others (Kemp, 1968; Wilkinson, 1971; Smith and Nagel, 1972; Brown, Lewis and Harcleroad, 1973) have expressed similar points of view. With audio-visual materials being acclaimed as being so vital to the learning environment, it is most

imperative that they be integrated into a unit of curriculum and instruction. This emphasis, according to Johnson (1969), "is consistent with the view that the media is the message. Recently the importance of a multi-media approach has been stressed (p. 127)."

As was pointed out by Hodgetts (1968) and Massey (1971) there is a lot of discontent expressed by students in Canada with the traditional modes of classroom instruction. This, however, is not only a Canadian phenomenon. Fransecky (1972) in a paper on the use of audio-visual materials stated:

Our students are demanding schooling that is more responsible and responsive; they are seeking programs that permit them a variety of communication opportunities and options in classrooms where they can write out, act out, speak out, and see out using the tools of visual technology to extend their total linguistic and communicative facility (p. 7).

In an attempt to provide the learning experiences suggested by Fransecky (1972) above, the materials to accompany "Problems of housing and planning in a growing urban centre" were produced.

"Problems of housing and planning in a growing urban centre" is part of a multi-media kit which was designed to provide a multi-sensory, multi-disciplinary approach to the overall topic of the St. John's project of Project Atlantic Canada, "Culture in transition: Problems of a changing life-style." The kit, to this date, contains:

- a) 4 student booklets
- b) 1 teacher's guidebook
- c) 1 slide tape production
- d) 1 street map of St. John's
- e) 1 copy of Plan 91
- f) 4 wall charts
- g) 8 aerial photographs
- h) miscellaneous resource sheets

It should be noted, however, that work on this kit will not cease with the completion of this thesis. It is intended that the developer of the unit, "Problems of housing and planning in a growing urban centre," as an active member of the St. John's team of Project Atlantic Canada will continue to develop materials.

#### Teaching strategies

Hodgetts (1974) in his Rationale for Canada studies stated that, "classroom teaching methods should grow from the materials being taught and from the rationale that determined their selection (p. 2)." The teaching strategies for the unit were developed with the intent that the teacher be given as much freedom as possible in utilizing his own creative talents. It is not the intention of the developer to have produced what Romey (1973) has called a "teacher proof curriculum." Therefore, the teaching strategies of

inquiry/discovery, group discussion, independent study, and lecture are to be considered only as recommendations to help achieve the intended learning outcomes for the unit. It is left entirely to the individual teacher to use any or all of the proposed teaching strategies for effective interaction between the students and the teacher, the teacher and the display, and the students and the display.

The questioning techniques and activities suggested as part of the teaching strategies were utilized to stimulate inquiry and discovery in the classroom environment. For example, number three, page one of the student text, Appendix A, "Contact the Statistics Canada office in your area to obtain information regarding the percentage of owned and rented houses in your province. Compare with that of Newfoundland," is indicative of the type of activities employed throughout the unit.

The nature of the questioning in the unit provides for many interpretations of a question. Opposing viewpoints are encouraged to enable students to resolve a conflict based on the many facets which comprise that problem. This technique is employed to foster a greater national understanding which is one of the aims of the Canada Studies Foundation. A further examination by the reader of the questioning techniques used in "Problems of housing and planning in a growing urban centre" will reveal



that many different types of questions as suggested by Bloom (1955) are evident throughout the unit. These include questions of knowledge, comprehension, application, analysis, synthesis, and evaluation.

#### Evaluation Procedure

Evaluation of the unit "Problems of housing and planning in a growing urban centre" has been and will continue to be in accordance with the procedures suggested by the Canada Studies Foundation evaluation officer (Carswell, 1972). The Canada Studies Foundation recommends evaluation of a formative nature throughout the developmental process. As some of the St. John's project is still in the developmental stage, evaluation of the unit was undertaken to achieve the aim of formative evaluation which, as stated by Scriven (1967), is "to identify aspects of the unit where revision is desirable (p. 42)." Briefly, the formative evaluation of the unit developed was as follows:

- a) content verified by outside experts;
- b) first draft revisions and second draft materials developed;
- c) field testing; and
- d) - analysis of field testing results.

Evaluation instruments developed by Weiss (1972) were used at various stages of the formative evaluation process.

"Rating scales for the validation of programs' (RSVP)"

(Weiss, 1972, Appendix C, page 122) was used in the formative evaluation of first-draft materials. Results from this evaluation resulted in the second-draft materials which were field tested. Analysis of the field testing was aided by the use of the "Student questionnaire for lesson (STQL)," Appendix F, page 160, and the "Teacher questionnaire for lesson (TEQL)," Appendix E, page 153. Information feedback in the form of written evaluation reports concerning areas not covered by the STQL and TEQL forms were provided by the piloting teachers.

In addition to the steps outlined above which are recommended by the Canada Studies Foundation for formative evaluation, the "Guiding questions for curriculum and instruction development" (Anderson, 1972) were applied to ascertain adherence to Johnson's theories at each stage of the development. Although the Canada Studies Foundation guiding questions (Hodgetts, Tomkins, and Bowles, 1974) were unavailable in the early stages of the development of "Problems of housing and planning in a growing urban centre," they were useful in affirming compliance with the criteria of the Canada Studies Foundation throughout the evaluation procedure. In addition, Fry's readability formula (Fry, 1968) was applied to determine the reading level of the student material.

Summary

In this chapter, the methodology employed in the development of the unit of curriculum and instruction, "Problems of housing and planning in a growing urban centre," was presented. The curriculum, the instructional plan, and the evaluation procedure for the unit were discussed. The chapter which follows will be concerned with the results of the formative evaluation of the unit.

## CHAPTER 4

### Formative Evaluation

The rationale and procedure for the formative evaluation of the unit, "Problems of housing and planning in a growing urban centre," have been outlined in the previous chapter. Formative evaluation (Scriven, 1967; Carswell, 1972) was used for the purpose of discovering, as suggested by Scriven (1967), "deficiencies and successes in the intermediate versions of a new curriculum (p. 51)." The unit, "Problems of housing and planning in a growing urban centre," is still in the formative evaluation stages. For the purposes of this study no summative evaluation activities will be reported. It is anticipated, however, that a summative evaluation of the unit will be undertaken in the fall of 1975, after the materials have been revised based on the formative evaluation. The formative evaluation of the unit, "Problems of housing and planning in a growing urban centre," will be discussed under the following headings: (1) Verification by outside experts, (2) Application of the guiding questions, (3) Application of Fry's readability formula, and (4) Field testing.

#### Verification by Outside Experts

This first step, verification by experts, was very important in the formative evaluation of the unit of

curriculum and instruction, "Problems of housing and planning in a growing urban centre." First-draft materials were submitted to experts in the fields of social studies education and audio-visual education at various stages of the developmental process. The comments of the experts were sought for the purpose of determining the validity and teachability of the materials developed.

Early in June, 1974, Dr. K. Matthews, an expert in Newfoundland history, was consulted to suggest sources to research which could aid the developer in the selection of the intended learning outcomes for the unit developed. By August, 1974, the intended learning outcomes had been identified and first-draft student reading materials had been prepared. At this time, Dr. R. M. Anderson and Mr. M. Brewster, consultants in the field of social studies education, were approached to read and evaluate the student materials to determine the validity of the substantive content of the student narrative. While the material was being read for its internal significance, the experts were asked to examine the material for its relevance to social studies and to make suggestions in structuring the materials and activities for use with junior high school students. In addition, Mr. M. Brewster was requested to complete the "Rating Scale for the Validation of Programs (RSVP)" instrument,

Appendix C, page 122, an instrument developed by Weiss (1972) to aid in establishing the validity of a unit in the formative evaluation stages.

The above-mentioned professionals were aware of the criteria of the Canada Studies Foundation which has been stated earlier in this study. They found that the content of the unit was valid, but reports of this initial examination of the materials indicated several discrepancies with regard to the teachability of the materials in keeping with the criteria of the Canada Studies Foundation. The discrepancies noted by the experts are summarized as follows:

1. materials were too expository in nature;
2. materials were not inquiry oriented enough;
3. materials were often not interdisciplinary enough;
4. materials were often too local in nature;
5. national concerns needed to be emphasized more;
6. more questions, activities, and projects were needed;
7. reading level was too high.

A revision of first-draft materials was undertaken based on the above-stated findings. The unit, "Problems of housing and planning in a growing urban centre," is a result of the suggested revisions of the first-draft materials. The form which now comprises the unit has been verified by experts as both valid and teachable.



A full report of the formative evaluation of the audio-visual materials included with the unit will be submitted to the Department of Curriculum and Instruction, Memorial University, by Bramwell Dawe upon completion of his internship report. Basically, when the audio-visual materials were submitted to Dr. G. Fizzard and Dr. D. Boehnker, experts in audio-visual education, it was decided that:

1. several slides had to be photographed again because of the poor quality of some of the original slides;
2. the audio-tape had to be recorded again because of several mistakes in the production of the tape;
3. the wall charts not be spirit-duplicated copies of originals but first quality originals;
4. a stereoscope be included in the multi-media kit to aid in the use of the aerial photographs;
5. a better reproduction of several of the pictures in the unit was required for the final product.

With the exception of several negative comments on the quality of the audio-tape and one negative comment about the quality of the wall chart, none of the other above-mentioned discrepancies were pointed out by the piloting teachers. Revisions of the audio-visual materials are presently being conducted.

### Application of the Guiding Questions

Two sets of guiding questions have been utilized in the development and formative evaluation of the unit "Problems of housing and planning in a growing urban centre." "Guiding questions to aid in the development of curriculum and instruction units (Anderson, 1972)," Appendix D, page 148, served to ensure an adequate application of Johnson's theories (1967, 1968). The "Guiding questions for developing Canada studies curricula (Hodgetts, Tomkins, and Bowles, 1974)," although not available prior to commencement of work on the development of the unit, were quite useful in determining whether or not the criteria of the Canada Studies Foundation had been adhered to throughout the development of the unit.

Formative evaluation takes part throughout the developmental process. It is therefore difficult to distinguish between the use of the "Guiding questions to aid in the development of curriculum and instruction units (Anderson, 1972)" in the development and formative evaluation of the unit since both activities occurred simultaneously. It was decided to include the discussion of the guiding questions in this section of the study because as Anderson (1972) states "the questions were designed to enable analysis as well as development (p. 6)." Johnson's theories were used as the theoretical framework for the unit developed. The guiding questions provided a means of checking whether

or not the theories of Johnson had been applied concurrently with the production of the unit.

The "Guiding questions to aid in the development of curriculum and instruction units (Anderson, 1972)" have been used by Cowan (1973), Fagan (1974), and several project teams of the Canada Studies Foundation. They have been found to be quite effective in developing and formatively evaluating units of curriculum and instruction. The questions are divided into five major groups and each group is further subdivided into three categories: a) designative - what is or will be, b) appraisive - what is wanted and, c) prescriptive - what should be done. The five major groups of questions are:

1. How will you select the I.L.O.'s from the cultural content?
2. How will you organize the I.L.O.'s?
3. How will you establish the relationship between instructional content (I.L.O.'s and instrumental content) and teaching strategies?
4. How will teacher Y complement the instructional plan?
5. How will you view the process of evaluation of curriculum development and instructional planning (Anderson, 1972, pp. 6-10)?

According to Anderson (1972), the above-stated questions can be used for the formative evaluation of units of curriculum and instruction. Throughout the development process the questions were considered to ensure that no discrepancies

appeared at any stage of formative evaluation of the unit, "Problems of housing and planning in a growing urban centre."

For example, the first major group of questions is as follows:

- 1.0 How will you select the intended learning outcomes (I.L.O.'s) from the cultural content?
- 1.01 What criteria did you use to select the I.L.O.'s?
- 1.02 Did you obtain the I.L.O.'s you desired?
- 1.11 What are desirable criteria for the selection of I.L.O.'s?
- 1.12 What are desirable I.L.O.'s?
- 1.21 If there is a discrepancy between desirable criteria and used criteria, then how should you deal with the discrepancy?
- 1.29 If there is a discrepancy between the obtained I.L.O.'s and desirable I.L.O.'s then how should you deal with the discrepancy?

From the teachable cultural content which is presented in Chapter Three, p. 27, the criteria of the Canada Studies Foundation were used to select both the general and specific intended learning outcomes for the unit. These criteria were also considered to be desirable criteria for the development of curriculum on problems of housing and planning. Thus, no discrepancy was evidenced between what is and what is wanted. Verification of the criteria by outside experts and field testing of the unit indicated that the I.L.O.'s were desirable and obtainable, thereby establishing again no divergence between what is and what is wanted. If a negative

response had ensued on any of the questions an immediate revision of the criteria or the I.L.O.'s would have been undertaken. Since no discrepancies were noted (a) between the criteria selected and desirable criteria, and (b) the desirable I.L.O.'s and the I.L.O.'s obtained, the questions under number two, "How will you organize the I.L.O.'s?" were deliberated. A similar procedure to that presented above was used for each of the remaining four major questions. Any variances noted under any of the major groups of questions resulted in an immediate revision and re-evaluation before proceeding to the next question. For discussion in detail of how the "Guiding questions to aid in the development of curriculum and instruction units (Anderson, 1972)" were applied to the development of a specific unit of curriculum and instruction, the reader is referred to Cowan (1973).

As was stated earlier, the "Guiding questions for developing Canada studies curricula (Hodgetts, Tomkins, and Bowles, 1974)" were unavailable at the outset of the development of the unit, "Problems of housing and planning in a growing urban centre." The questions presented in Chapter Two, page 21, of this thesis, however, did aid greatly in ascertaining whether or not the criteria of the Canada Studies Foundation had been achieved when the unit was completed. When each of the questions was considered in the formative evaluation of the unit developed,

there was no apparent divergence from the criteria of the Canada Studies Foundation. For example when question (g), series one, "What means best ensure that a comparative element is built into work in Canada Studies?" was considered it was determined that the questioning techniques, activities, and materials throughout the unit, "Problems of housing and planning in a growing urban centre," provide an incentive to conduct comparison studies of regional problems which have national significance (Appendix A). Furthermore, question (a), series three, "What knowledge/skill objectives will contribute to the overall goal of Canada studies?," and question (b), series three, "What value/attitude objectives will contribute to these goals?," show an additional illustration of how the guiding questions (Hodgetts, Tomkins, and Bowles, 1974) were deliberated in the formative evaluation of the unit. The answers to these questions are demonstrated in the general and specific intended learning outcomes which were designed for the unit and are listed on pages 32-37 of this thesis. It seems that even though the developer was unaware of the guiding questions during the early stages of the development of the unit, each of the questions had been intuitively considered in developing the unit, "Problems of housing and planning in a growing urban centre."

#### Application of Fry's Readability Formula

Since the student narrative was developed for use with students of a reading level of grade seven or greater,



some check on the reading level of the written materials was necessary. To facilitate this check, Fry's Readability Graph (Fry, 1968) was selected. According to Fry his readability formula correlates highly with the Dale-Chall, S.R.A., Flesch, and Spache formulas which have been used widely in establishing reading levels for student materials (p. 577). Fry's Readability Graph was chosen by the developer because it presents a faster and simpler method of determining readability than the other formulas presently in existence. In addition, Cowan (1973) used Fry's Readability Graph to establish the approximate reading level of the student booklets for the unit, "Maritime Archaic Indians" at the grade five level (p. 42). Fagan (1974) applied Fry's readability formula to the unit "Resource-based one industry towns" and discovered the reading level to be approximately grade nine (p. 46). Field-testing of both units verified that the reading level was appropriate to the grade levels for which the units were developed. Both writers have recommended Fry's readability formula as an adequate and useful means of establishing reading level in student materials. The directions for using the readability graph are as follows:

1. Select three one-hundred-word passages from near the beginning, middle and end of the book. Skip all proper nouns.
2. Count the total number of sentences in each hundred-word passage (estimating to nearest tenth of a sentence). Average these three numbers.

3. Count the total number of syllables in each hundred-word sample. There is a syllable for each vowel sound; for example: cat (1), black-bird (2), continental (4). Don't be fooled by word size; for example: polio (3), through (1). Endings such as -y, -ed, -el, or -le usually make a syllable, for example: ready (2), bottle (2). I find it convenient to count every syllable over one in each word and add 100. Average the total number of syllables for the three samples.
- A. Plot on the graph the average number of sentences per hundred words and the average number of syllables per hundred words. Most plot points fall near the heavy curved line. Perpendicular lines mark off approximate grade level areas. (Fry, 1968, p. 514)

An example of how the readability formula was applied to the unit "Problems of housing and planning in a growing urban centre," is provided below:

	Sentences per 100 words	Syllables per 100 words
100 word sample page 1	5.2	141
100 word sample page 5	8.1	142
100 word sample page 10	4.5	142
	<u>17.8</u> ÷ 3	<u>425</u> ÷ 3
	= 5.9	= 141.7

Plotted on the graph, figure 2, it was discovered that the student reading material fell within the grade seven area. Therefore, the approximate reading level of the student materials was grade seven. It was assumed by the developer that students who have achieved a reading level of grade seven or greater would have little difficulty with the student

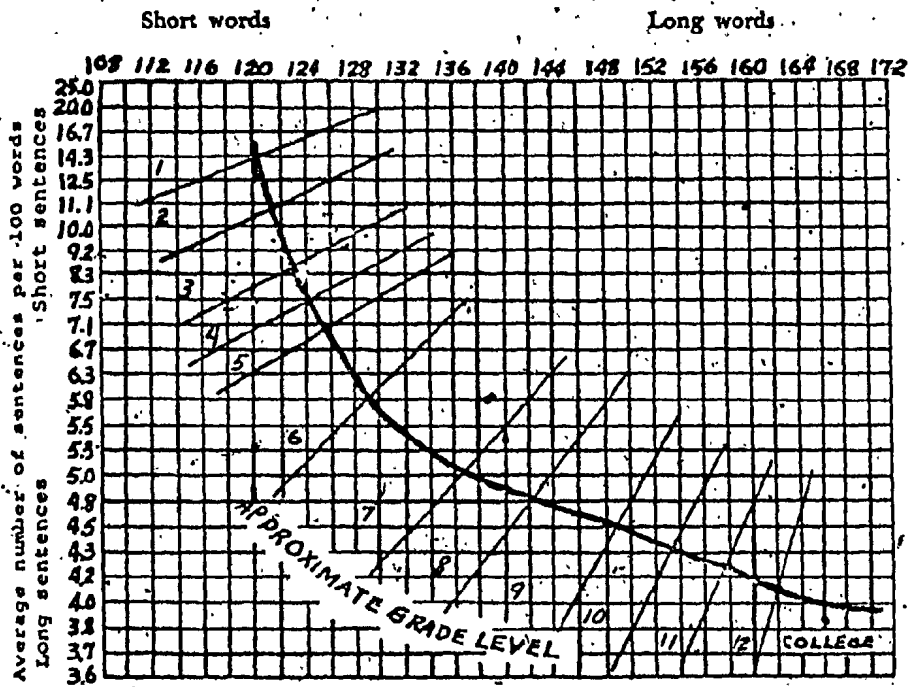

Fig. 1. "Graph for estimating readability (Fry, 1968, p. 577)."

reading materials. The piloting teachers verified that these reading materials could be read easily by students who had achieved proficiency in reading at the grade seven level.

#### Field Testing

In March, 1975, the Canada Studies Foundation sponsored a national dissemination conference at Hotel Newfoundland in St. John's, Newfoundland. At that time, the Newfoundland and Labrador teams of Project Atlantic Canada presented their projects to teachers from all across Canada. One of the major purposes of the conference and each team presentation was to provide an in-service session for teachers who were willing to field test the materials developed. Teachers from St. John's to Saskatoon attended the three day session of the St. John's project, "Culture in transition: Problems of a changing lifestyle." The unit of curriculum and instruction, "Problems of housing and planning in a growing urban centre," was a part of the St. John's project. To this date, of the teachers who agreed to pilot the St. John's project materials, two junior high school teachers and one elementary school teacher and their respective classes have completed the unit, "Problems of housing and planning in a growing urban centre."

The unit has been piloted in two grade eight classes and two grade nine classes by Mr. A. Bernard, Miscouche

Regional High School, Miscouche, Prince Edward Island; in one grade seven-eight class by Mr. P. Lowen, Vineland Public School, Vineland, Ontario; and in one grade six class by Mr. L. Chaulk, A. G. Hiscock Academy, Corner Brook, Newfoundland. At the end of the piloting session the three teachers were requested to complete a questionnaire, "Teacher questionnaire for lesson (TEQL) (Weiss, 1972)" to aid in the evaluation of the unit. A student evaluation of the unit was sought with the use of the questionnaire, "Student questionnaire for lesson (STQL) (Weiss, 1972)." In addition, informal written evaluations by both teachers and students were returned with the completed questionnaires. A report of these teacher and student evaluations follows.

#### Teacher questionnaire for lesson (TEQL).

The TEQL, Appendix E, page 153 of this thesis is one of several formative evaluation instruments developed by Weiss (1972). The TEQL instrument was used to identify teacher reactions to the unit, "Problems of housing and planning in a growing urban centre." This TEQL form was used by Fagan (1974) and found to be quite adequate in obtaining a teacher's point of view in the areas of enjoyment, understanding, encouragement, and appropriateness of the unit being evaluated. The teachers' reactions to the unit, "Problems of housing and planning in a growing

urban centre," were as follows:

1. All three teachers enjoyed working with the students and the materials in the unit.
2. Two of the teachers enjoyed the activities in the unit. The teacher from Corner Brook, however, reacted negatively toward the use of some of the activities with grade six students.
3. All three teachers expressed an understanding of the students, materials, and activities throughout the unit.
4. All three teachers understood the purpose of the materials in the unit. On the other hand, the teacher from Corner Brook made a comment that the maps and aerial photographs were too difficult to be used with a grade six class.
5. All three teachers encouraged their students and expressed the opinion that the students enjoyed working with the unit.
6. All three teachers agreed that the students understood the materials and activities which were used during the unit.
7. All three teachers indicated that the students encouraged each other throughout the unit. In addition, two of the teachers indicated that the students encouraged the teacher. The teacher from Corner Brook, however, indicated very little encouragement from his students.

8. Two teachers pointed out that the materials were appropriate to the students. A negative reaction was received from the teacher in Corner Brook when he pointed out that some of the materials were not very appropriate to grade six students.
9. All three teachers indicated that the materials were appropriate to their method of teaching.
10. Two teachers thought the activities were appropriate to the students. The teacher from Corner Brook, nevertheless, stated that some of the activities were a little too difficult for grade six students.
11. All three teachers enjoyed and understood the purpose of the location of the class for the activities and the materials in the unit. [According to Weiss, 1972, class location refers to "classroom, special instructional areas (library, laboratory, etc.), outdoor instructional setting (school yard, park, stream, woods, etc.), indoor instructional setting (museums, factories, shopping centres, parliament buildings, etc.) (p. 70)"]

The informal written evaluations of all three teachers were very positive toward the unit. The teachers indicated that the materials and activities in the unit stimulated studies of problems of housing and planning in their own local areas. When the studies were completed, the students compared the



local problems with similar problems in St. John's and other Canadian cities. Indicative of the types of studies undertaken by the students in each of the schools is the list which was submitted by the teacher in Corner Brook. Problem areas which were investigated by his class were:

1. an urban renewal scheme which was the subject of much controversy a few years ago;
2. the construction of a number of low rental housing units in a relatively affluent area;
3. the expropriation of part of a tree nursery to make way for a new housing development;
4. problems caused by a lack of planning in the early days.

The teacher from Vineland stated that the main strength of the unit is "that it is an excellent springboard from which to launch into a local study, and then to compare the local area with the transition being experienced in St. John's."

The teacher from Miscouche expressed a similar point of view and submitted reports of several of the projects which were researched by students in his classes.

Student questionnaire for lesson (STOL).

The Student questionnaire for lesson (STOL), Appendix F, page 160, is another of the formative evaluation instruments

instruments developed by Weiss (1972). The STQL form was designed to obtain the same type of information from the students in the areas of enjoyment, understanding, encouragement, and appropriateness that was requested from the teachers.

Among the teachers who piloted the unit, "Problems of housing and planning in a growing urban centre," some confusion arose over the administration of the STQL instrument. The teachers were requested to have each student complete a questionnaire at the end of the unit. This, however, was not the procedure followed in each school. As a result, the student evaluation procedure, using the STQL form, will be reported separately for each school.

Miscouche Regional High School  
Prince Edward Island

Fifty-one grade nine students and forty-six grade eight students in four classes participated in the evaluation of the unit, "Problems of housing and planning in a growing urban centre." Only the questions which the teacher considered appropriate to the field testing of the unit in his classes were answered by the students. For a tabulation of the outcomes see Table 1, Appendix C, page 172. The results of the student responses to the questionnaire were as follows:

1. Seventy-six percent (76%) of the students replied that they enjoyed working with the teacher and the other students throughout the unit.

2. Sixty-eight percent (68%) of the students enjoyed the materials and activities in the unit.
3. Eighty-five percent (85%) of the students enjoyed the location of the class for the activities of the unit.
4. Seventy-six percent (76%) of the students understood the materials and activities which were used by the teacher in the unit.
5. Eighty-nine percent (89%) of the students understood the purpose of the materials and the purpose for the location of the class throughout the unit.
6. Only twenty-six percent (26%) of the students indicated any encouragement from either the teacher or other students during the unit. The teacher, however, reported that the students encouraged both the teacher and each other throughout the field testing.
7. Eighty-six percent (86%) of the students felt that the materials and activities of the unit were appropriate to them.
8. Seventy-seven percent (77%) of the students indicated that the materials and activities were appropriate to other students.

Vineland Public School  
Vineland, Ontario

The unit, "Problems of housing and planning in a

growing urban centre," was piloted in the class combining grades seven and eight at Vineland Public School. A total of twenty-eight (28) students participated in the field testing of the unit. The teacher requested the students to complete an STQL instrument at two stages of the field testing of the unit. The first STQL form was completed after a lesson on nineteenth century St. John's which is presented for discussion in the first section of the student narrative. The second STQL form was completed after a reaction survey to future developments in Vineland, one of the culminating activities which the teacher incorporated into the unit. For the purposes of this study, the student responses to both administrations of the STQL form were totalled and averaged (Table 2, Appendix G, page 174) to attain the following conclusions:

1. Ninety-one percent (91%) of the students indicated that they enjoyed working with the materials, activities, teacher, and other students throughout the unit.
2. Ninety-one percent (91%) of the students enjoyed the grouping and the location of the class.
3. Ninety-nine percent (99%) of the students indicated that the teacher enjoyed working with the materials, activities, and students during the field testing.

4. Ninety-six percent (96%) of the students felt that the teacher enjoyed the grouping and location of the class.
5. Ninety-nine percent (99%) of the students reported that they understood the other students, the materials, and the activities throughout the unit.
6. Ninety-four percent (94%) of the students understood the purpose of the materials, activities, class grouping, and class location during the field testing.
7. Ninety-nine percent (99%) of the students indicated that the teacher understood the students, the materials, and the activities throughout the unit.
8. Ninety-six percent (96%) of the students considered that the teacher understood the purpose of the materials, the class grouping, and class location.
9. Fifty-five percent (55%) of the students stated that they encouraged the teacher and the other students during the unit.
10. Seventy percent (70%) of the students indicated that the teacher encouraged the students throughout the unit.
11. Ninety-three percent (93%) of the students pointed out that the materials and activities were appropriate to both the student and the teacher.
12. Ninety-four percent (94%) of the students indicated that the class grouping and class location were appropriate to both the students and the teacher.

13. Ninety-five percent (95%) of the students responded that the location of the class was relevant to the students' use of the materials and the teacher's method of teaching.

A. G. Hiscock Academy  
Corner Brook, Newfoundland

The unit, "Problems of housing and planning in a growing urban centre," was piloted in one grade six class of twenty-six (26) students at A. G. Hiscock Academy. The teacher returned only one STQL form which represented the consensus of opinion of the majority of the class members on each of the items. The reactions of the students of this class toward the unit are outlined as follows:

1. Most of the students enjoyed working with the materials, activities, teacher, and other students throughout the unit.
2. Most of the students enjoyed the class grouping, but did not enjoy the class location during the field testing.
3. Most of the class agreed that the teacher enjoyed working with the students, activities, and materials during the unit.
4. Most of the students indicated that the teacher enjoyed the location of the class and the way the students were grouped for the unit.

5. Most of the students understood the other students, materials, and activities throughout the field testing of the unit.
6. Most of the students understood the purpose of the materials, activities, class grouping, and class location that were used for the unit.
7. Most of the students agreed that the teacher understood the materials, activities, and students during the piloting of the unit.
8. Most of the students indicated that the teacher understood the purpose for the materials, class grouping, and class location.
9. Most of the students considered that they encouraged the teacher and other students throughout the unit.
10. Most of the students indicated that the teacher encouraged the students and the students encouraged the teacher throughout the field testing of the unit.
11. Most of the students agreed that the materials and activities that were used were appropriate to both the students and the teacher.
12. Most of the students pointed out that the class grouping was appropriate.
13. Most of the students stated the location of the class was relevant to the teacher's method of teaching.



In summary, regardless of the procedure employed by the three teachers for the administration of the STQL instrument, the following major conclusions can be determined from the student responses to the questionnaire.

1. The majority of the students indicated that both the student and the teacher enjoyed the materials, activities, class grouping, and class location while participating in the field testing of "Problems of housing and planning in a growing urban centre."
2. The majority of the students felt that both the student and the teacher understood the materials, activities, class grouping, and class location that were used throughout the field testing of the unit.
3. The majority of the students signified that both the student and the teacher encouraged many social interactions during the piloting of the unit, "Problems of housing and planning in a growing urban centre."
4. The majority of the students noted that both the student and the teacher agreed that the materials, activities, class grouping, and class location were appropriate throughout the field testing of the unit.

The teachers' responses on the TEQL form have supported the majority of the above-stated findings from the student questionnaire. In all cases the teachers have indicated that both the student and the teacher enjoyed,

encouraged, and understood the activities, materials, class grouping, and class location throughout the field testing of the unit. Only two of the teachers considered the materials to be appropriate for their classes. The teacher from Corner Brook expressed the opinion that some of the materials, in particular the maps and aerial photographs, were too difficult for use with grade six students, and, therefore lacked appropriateness to grade six. Since the students from Corner Brook were asked to evaluate only the materials and activities which were used in their classes, the opinion expressed by the teacher was not evidenced in the student questionnaire.

#### Summary

In this chapter a report of the formative evaluation of the unit, "Problem of housing and planning in a growing urban centre," was discussed, the procedure for the verification of the unit by outside experts was explained, the method employed in applying the "Guiding questions to aid in the development of curriculum and instruction units (Anderson, 1972)" and the "Guiding questions for developing Canada studies curricula (Hodgetts, Tomkins, and Bowles, 1974)" in the development and evaluation of the unit were outlined. Fry's readability formula (Fry, 1968) was described with an example of how the reading level in the unit was established, and, finally, a

full report of the field testing results was presented. The next chapter will give the summary, conclusions, and recommendations which result from this study.

## CHAPTER 5

### Summary, Conclusions, and Recommendations

#### Summary

The major purpose of this study was to develop a unit of curriculum and instruction based on the theories of Mauritz Johnson, Jr., (1967, 1968) and the criteria of the Canada Studies Foundation. The background and justification of the study were presented followed by a statement of the problem, the limitations of the study, and a definition of terms to be used throughout the study. A review of some of the related literature explicated Johnson's theories, the criteria of the Canada Studies Foundation, and the unit approach to developing curricula. The methodology employed in developing the unit was explained, and the formative evaluation of the unit was reported in some detail.

The unit, "Problems of housing and planning in a growing urban centre," was designed for use with junior high school students who have achieved a reading level of grade seven. The unit is interdisciplinary in nature as judged by experts in the fields of social studies education and audio-visual education. The development and formative evaluation of the unit have guided the developer to the conclusions and recommendations which are listed below.

### Conclusions

The following conclusions were reached as a result of this study.

1. Johnson's theories (1967; 1968) can be used as a theoretical framework on which to build a unit of curriculum and instruction.
2. The criteria of the Canada Studies Foundation can be incorporated into the development of a unit of curriculum and instruction.
3. The theories of Mauritz Johnson, Jr., used in conjunction with the criteria of the Canada Studies Foundation can provide a useful framework for involvement in curriculum development by an inexperienced developer.
4. The "Guiding questions to aid in the development of curriculum and instruction units (Anderson, 1972)" can aid in the formative evaluation of units of curriculum and instruction.
5. The "Guiding questions for developing Canada studies curricula (Hodgetts, Tomkins, and Bowles, 1974)" can be useful in the evaluation process of curriculum development.
6. The unit "Problems of housing and planning in a growing urban centre" can be successfully taught to junior high school students.
7. Both students and teachers enjoyed and understood the materials and activities of this unit.

8. Both students and teachers considered the materials and activities used throughout the unit to be appropriate.
9. The unit can be used to supplement existing social studies programs in Canada studies.

#### Recommendations

Based upon the development and formative evaluation of the unit of curriculum and instruction "Problems of housing and planning in a growing urban centre," it is recommended:

1. that further units of curriculum and instruction be developed based on the theories of Mauritz Johnson, Jr., and the criteria of the Canada Studies Foundation;
2. that the Canada Studies Foundation formulate an explicit statement of the criteria to present to all project teams;
3. that the "Guiding questions for developing curricula in Canada studies" be presented to all project teams prior to the beginning of developmental work in Canada studies;
4. that materials for the multi-media kit of which "Problems of housing and planning in a growing urban centre" is a part, continue to be improved, developed, and implemented.

5. that a summative evaluation of the developed unit be conducted at some later date;
6. that the Canada Studies Foundation continue to promote projects to develop curricula in Canada studies.



## References

- Anderson, R. M. Guiding questions to aid in the development and evaluation of curriculum and instruction units. A proposal to team members of Project Atlantic Canada, August, 1972. (mimeo.)
- The Canada Studies Foundation as an idea, not an organization. A paper presented to the Newfoundland History and Social Science Council, May, 1973. (mimeo.)
- and J. B. Roald. Teacher initiative in curriculum development: Implications for teacher education. A paper presented to the Canadian Association of Professors of Education, May, 1973. (mimeo.)
- Anspach, L. A. A history of the island of Newfoundland. London: T & J Allman, 1819.
- Bloom, B. S. (Ed): Taxonomy of educational objectives: Cognitive domain. New York: David McKay Co., 1956.
- Brown, J. W., R. B. Lewis, and F. F. Harclerod. A.V. instruction: Technology, media, and methods. New York: McGraw Hill, 1973.
- Canada, Bureau of Statistics. Census of Canada 1949-1971.
- Canada Studies Foundation. Memorandum 6. Toronto: Canada Studies Foundation, 1970. (mimeo.)
- Canada Studies Foundation annual report.  
Toronto: Canada Studies Foundation, June 30, 1972.
- Canada Studies Foundation annual report.  
Toronto: Canada Studies Foundation, June 30, 1973.
- Carswell, R. Canada Studies Foundation evaluation proposal. Draft for discussion, 1972. (mimeo.)
- Cowan, F. W. Newfoundland's first people: The Maritime Archaic Indians: A unit of curriculum and instruction based on the theories of Mauritz Johnson, Jr. Unpublished masters thesis, Memorial University of Newfoundland, 1973.
- Dale, E. Audio visual methods in teaching. New York: Holt, Rinehart and Winston, 1969.
- Darrow, H. F. Social studies for understanding. New York: Bureau of Publications, Teachers College, Columbia University, 1964.

Doll, R. B. Curriculum improvements: Decision making and process. Boston: Allyn and Bacon, 1964.

Fagan, L. P. Resource-based single industry communities: A unit of curriculum and instruction based on the theories of Mauritz Johnson, Jr., and the criteria of the Canada Studies Foundation. Unpublished masters thesis, Memorial University of Newfoundland, 1974.

Financial Post. 1958-1971.

Fransecky, R. B. Visual literacy. Audio Visual Instruction May, 1972, 17(5), 7-11.

Fry, E. Readability formula that saves time. Journal of Reading, April 1968, 11, 513-516.

Gagne, R. M. Curriculum research and the promotion of learning. In B. O. Smith (Ed.) Perspectives of curriculum evaluation. Chicago: Rand McNally, 1967.

Hanna, L. A., G. L. Potter, and N. Hagaman. Unit teaching in the elementary school. New York: Rinehart, 1955.

Unit teaching in the elementary school. Revised edition. Holt, Rinehart, and Winston, 1966.

Harvey, M., and J. Hatton. Newfoundland: The oldest British colony. London: Chapman and Hall Limited, 1883.

Hill, W. Variety of unit plans and instruction. In J. C. McLendon (Ed.), Readings on elementary social studies: Emerging changes. (Second Edition), Boston: Allyn and Bacon, 1970, 407-412.

Hodgetts, A. B. What culture? What heritage? Toronto: The Ontario Institute for Studies in Education, 1968.

Rationale for Canada studies. OTF occasional papers. Toronto: OTF, 1974, 11, 1-5.

Hodgetts, A. M., G. S. Tomkins, and R. P. Bowles. Guiding questions for developing Canada studies curricula. OTF occasional papers. Toronto: OTF occasional papers. Toronto: OTF, 1974, 11, 16-20.

Horwood, H. The traveller's Canada: Newfoundland. Toronto: Macmillan of Canada, 1969.

- Jarolimek, J. Social studies in the elementary school. Third edition. New York: Macmillan Company, 1967.
- Johnson, M., Jr. Definitions and models in curriculum theory. In E. C. Short and G. C. Marconnit (Eds.), Contemporary thought on public school curriculum. Dubuque, Iowa: Wm. C. Brown, 1967.
- \_\_\_\_\_. The translation of curriculum into instruction, Journal of Curriculum Studies, 1969, 1(2), 115-131.
- \_\_\_\_\_. Managerial and technical aspects of educational program evaluation. Educational Theory, 1974, 24, 374-385.
- Joyce, B. R. Strategies for elementary social science education. Chicago: Science Research Associates, 1965.
- \_\_\_\_\_. New strategies for social education. Chicago: Science Research Associates, 1974.
- Kemp, J. E. Planning and producing audio visual materials. Scranton, Penn.: Chandler, 1968.
- Kenworthy, L. S. Social studies for the seventies. Waltham, Mass.; Blaisdell Publishing Company, 1970.
- Krathwohl, D. R., et. al. Taxonomy of educational objectives: Affective domain. New York: David McKay, 1964.
- Lavatelli, C. S., et. al. Elementary school curriculum. New York: Holt, Rinehart and Winston, 1972.
- MUN Extension Service, in co-operation with Central Mortgage and Housing. Our city in conference. A report of a three day conference, May 25-27, St. John's, 1973.
- Massey, N. B. Canadian studies in Canadian schools. A report for the curriculum committee for the Council of Ministers of Education on the Study of Canada, Canadians and Life in Canada, September, 1971.
- Matthews, K. A history of the West of England - Newfoundland fisheries. Unpublished doctoral dissertation, University of Oxford, 1968.
- Michaelis, J. U., et. al. New designs for the elementary school curriculum. Toronto; McGraw-Hill, 1967.
- Mowatt, F. Newfoundland; Three hundred year gone by. New York: St. Martin's Press, 1971.

- Muessig, R. H. Bridging the gap between textbook teaching and unit teaching. In J. Jarolimek (Ed.), Readings for social studies in elementary education, Second Edition. London: Collier-Macmillan, 1965.
- Newfoundland Historic Trust. (no title). Brief submitted to the St. John's municipal council and planners. St. John's, 1969.
- Preserving historic St. John's. Report submitted to the public commissioner on Plan 91. St. John's, 1972.
- Perlin, A. B. The story of Newfoundland. Grand Falls: Anglo-Newfoundland Development Company, 1959.
- St. John's: Newfoundland's ancient capital takes on new dimensions. The Atlantic Advocate. June, 1960, 37-50.
- Preston, R. C. Teaching social studies in the elementary school. New York: Rinehart, 1950.
- Proctor and Redfern Limited, St. John's, and Patterson Planning and Research Limited, Toronto. St. John's urban region study. St. John's, 1973.
- Project Planning Associates Limited. City of St. John's, Newfoundland, urban renewal study. Prepared for municipal council. Toronto, 1961.
- Blackhead, St. John's urban renewal scheme residential standards and rehabilitation. Final Report, Toronto, 1966.
- Prowse, P. W. The St. John's fire of 1892. The Newfoundland Quarterly. Summer, 1962, 7-10.
- Richmond, W. K. The school curriculum. London: Methuen, 1971.
- Romey, W. D. The curriculum-proof teacher? Phi Delta Kappan, 1973, 54, 407-408.
- Rothney, G. O. Newfoundland: A history. Ottawa: The Canadian Historical Association, 1964.
- St. John's Daily News. 1894-1896, 1898-1974.
- St. John's Evening Telegram. (1878, 1880-1886, 1888, 1890-1974.

Saylor, J. G. and W. M. Alexander, Curriculum planning for modern schools. New York: Holt, Rinehart, 1966.

Scriven, M. The methodology of evaluation. In R. W. Tyler, et. al., (Eds.) Perspectives in curriculum evaluation. Chicago: Rand-McNally, 1967.

Short, E. C. and G. D. Marconit, (Eds.) Contemporary thought on public school curriculum. Dubuque, Iowa: Wm. C. Brown, 1967.

Smallwood, J. R. (Ed.) The book of Newfoundland. St. John's: Newfoundland Book Publishers Limited, 4 vols., 1937-1947.

Smith, H. R. and T. S. Nagel. Instructional media in the learning process. Columbus, Ohio: Charles E. Merrill, 1972.

Sunderland and Simard, Ltd. Plan 91: City of St. John's, Newfoundland: Draft master plan. Report, Montreal, 1970.

Taba, H. Curriculum development: Theory and practice. New York: Harcourt, Brace and World, 1962.

Tocque, P. Newfoundland as it was and as it is in 1877. Toronto: John B. Magurn, 1878.

Tomkins, G. S. Memorandum C: Rationale for Canada studies program. Toronto: Canada Studies Foundation, 1972. (mimeo.)

Tyler, R. W. Basic principles of curriculum development. Chicago: University of Chicago Press, 1950.

Weiss, J., J. Edwards and O. Dimitri, Formative curriculum evaluation (field testing draft). Toronto: O.I.S.E., 1972.

Wilkinson, C. E. Educational media and you. Toronto: G.L.C. Educational Material and Services. 1971.

Wilson, G. M. Looking critically at unit teaching, The Instructor, March, 1963, 93-94.

Wright, E. A., et. al. Elementary school curriculum; Better teaching now. New York: Macmillan, 1971.

Appendix A

Student Narrative



Culture

In Transition

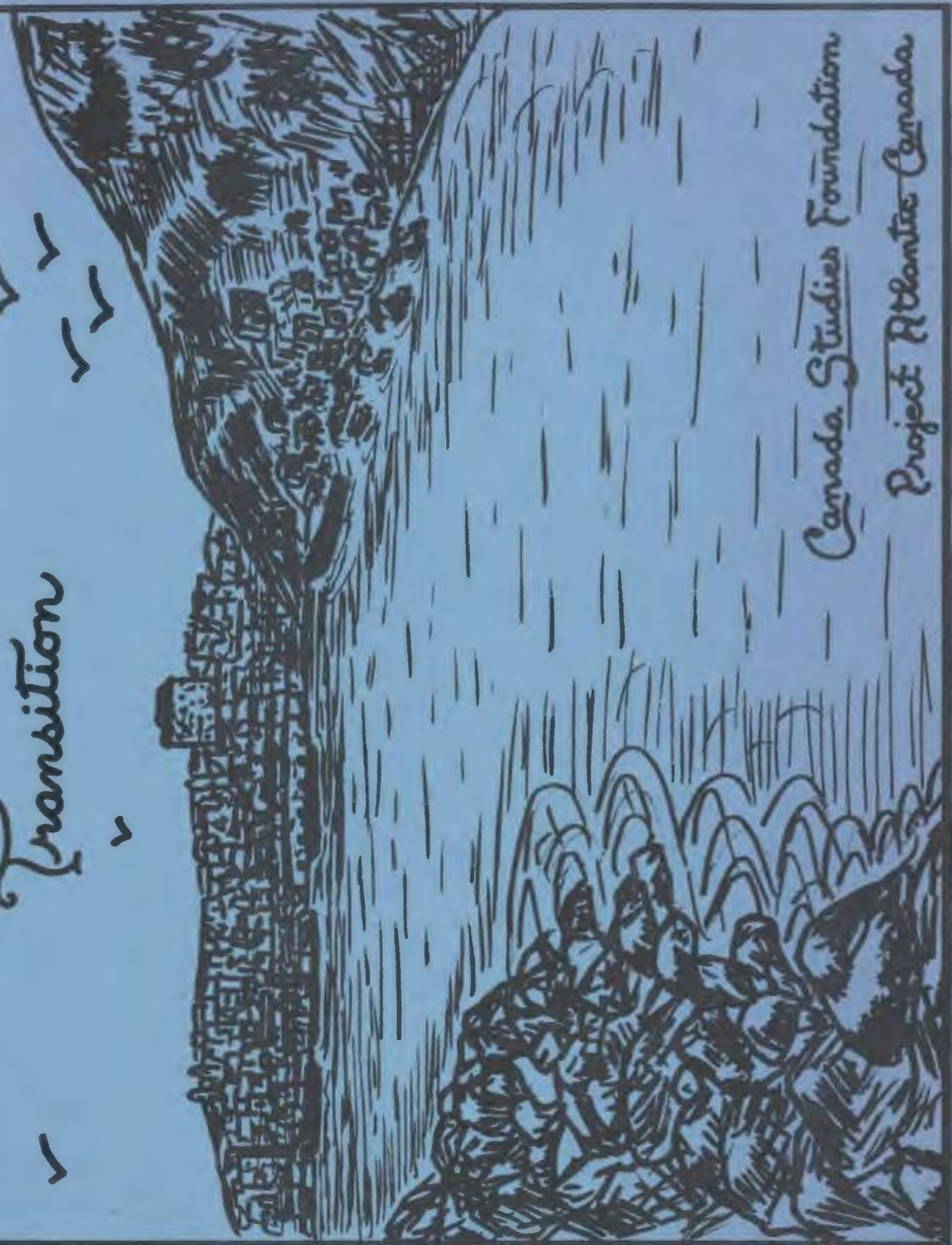
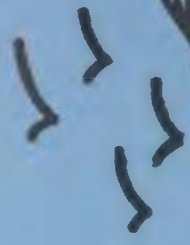

Canada Studies Foundation

Project Atlantic Canada

ST. JOHN'S

ST. JOHN'S PROJECT

TEAM PERSONNEL

Patricia M. Connolly

Frederick T. Butler

Malcolm B. Squires

Bramwell Dawe

CURRICULUM DEVELOPMENT CONSULTANT

Dr. Robert M. Anderson

Dept. of Curriculum and Instruction

Memorial University of Newfoundland



### St. John's an Urban Center: Housing & Planning

Throughout its history St. John's always had a housing crisis of one type or another. Up to the year 1819, permission had to be obtained from the governor in order to build a house - chimney or barn. No plan had ever been drawn up for an organized expansion of the city. Therefore, the St. John's of the eighteen hundreds was a 'bodge-podge' of houses and barns scattered over a wide area. Often there were groups of wooden frame houses strung together, row upon row throughout the city with no thought of safety or location. It seems that all that mattered to the St. John'sman of the nineteenth century was a roof over his head.

Throughout the nineteenth century St. John's was plagued by a series of five disasters. These disasters came in the form of fires which swept through various sections of the city, culminating in 1892 with a fire which almost levelled the whole city. After either one of these fires it would have been the ideal time to start the development of a well-planned city. But behold thousands of people were without adequate accommodations and winter was fast approaching. Thus, houses were built as quickly and as cheaply as possible in order to house the homeless thousands.

With an influx of new industry and a corresponding growth in population, the twentieth century has created its own crisis. The problem at present is providing enough housing for a growing population. This coupled with poor town planning in the past has created many problems in the St. John's of 1974. In recent months, the increasing costs of construction materials have given a new twist to the perennial housing crisis.

That is to provide adequate as well as economical housing to the consumer in the St. John's of today.

1. "St. John's has always had a housing crisis of one type or another." Discuss.
2. According to the Newfoundland and Labrador Housing Corporation Annual Report, 1972, we find that Newfoundland has the strongest tradition of home ownership in Canada (84.1% owned homes, 15.9% rented.... In Canada 63.1% owned homes, 39.4% rented.) Do you think that this tradition adds to or helps to alleviate the housing crisis?
3. Contact the Statistics Canada office in your area to obtain information regarding the percentage of owned and rented houses in your province. Compare with that of Newfoundland.
4. List in two columns what you think would be the advantages and disadvantages of (a) home ownership (b) renting. Taking these advantages and disadvantages into consideration which would you prefer (a) ownership or (b) rental? Why?

### A Description of Nineteenth Century St. John's

What did St. John's look like in the 1800's? If we read a description of the town, it does not seem to be very impressive. The main road was called the Lower Path. This is present-day Water Street. This road was the business center of the town. It was long and narrow, and zig-zagged its way along by the harbour. In some places it was only twelve feet wide. A large cliff near one end prevented it from being widened. On the south side of the Lower Path there were wharves and the merchants had some stores. On the north side there were fish flakes and small wooden houses. No public buildings were to be found in St. John's at this time.

There were also no sidewalks. The people had

to walk under fish flakes or along little rough paths littered with garbage. All of the streets were narrow and unpaved. They also had no lights of any kind and they were very, very dirty. But even in the nineteenth century the importance of St. John's and also the importance of Water Street was recognized by the inhabitants of the island. As one writer of the time states some problems did exist on the great street of commerce.

"If Newfoundland is St. John's, then St. John's is Water Street. The great merchants here are the descendants... of the English merchant-adventurers of ancient days. Their (businesses) are huge general stores (like those of the Hudson's Bay Company ... (without) beauty, either within or without ... There seems to be no form or method to these stores). Slippers are ... dragged out of biscuit boxes, and barrels ... (market flour are (often found, to the surprise of the clerk) to contain corsets ..." (Willson, 1897, p. 24).

1. The map on the left is part of a modern St. John's street map. Using what you have read as a guide, see if you can trace the limits of the town during the early days of the nineteenth century. (One hint:- Limekiln Hill is now Lime St.)
2. Were there any special districts in your community in those days? If there were, see if you can discover some of their names.
3. Trace the history of how the special districts in your community got their names.

### Twentieth Century St. John's

As can be seen from the map on the \*Map is in the multi-media kit

STOP, LOOK AND INQUIRE



Homes Under Construction In The Northeast Land Development Area. Can You See Any Examples Of The New Contrasting And Blending With The Old.

87

previous page many of the original street names in the city remain. But the face of the city has changed drastically during the twentieth century.

From the picture on the opposite page can you see any examples of the new blending with the old in St. John's? List those that you can find.

Many of the changes are the direct result of urban renewal schemes. Others result from the expansion of the city.

After viewing the slide tape presentation and closely looking at the picture of St. John's, write a description of modern day St. John's.

#### Town Planning

As mentioned earlier very little, if any, planning went into the construction of the town of St. John's. But by 1944 the St. John's Housing Corporation was set up to plan the expansion of the city. Many of the new housing subdivisions in the city today are the direct result of plans initiated by the Corporation.

Since 1969 a series of development plans have been proposed for the St. John's area. Some of these plans are as follows:

#### St. John's Urban Region Study 1973

The current regional development proposals were prepared by consultants to the Provincial Government. This study is a development plan. It also proposes changes to the form of government in the metropolitan area.

#### Plan 91, 1972

Plan 91 is a proposed 20 year master plan for the city. It was prepared by consultants to the Municipal Council. The proposals were the subject of public hearings in April, 1972. The Municipal Council has not formally discussed the proposals since the public hearings. Plan 91 does not establish priorities. It is noted, however, that the municipal government has since given the go ahead for Atlantic Place. It has also consented to a new Trisec development. However, none of these were considered or recommended in Plan 91.

#### Transportation Plan: - City of St. John's 1971

This is a study of transportation in the city. It was prepared by consultants to the Municipal Council. It is an integral part of Plan 91. The Plan is for a 20 year period. A capital works program for the first five year period is specific.

#### Environment 2001, 1971

This is an integrated plan to utilize the natural waters of the Quidi Vidi water system in St. John's. The plan was prepared by the Working Group on Environment. This is a voluntary environmental protection organization. The study and recommendations were submitted to various levels of Government. The Municipal Council has co-operated with the Working Group on Environment on some projects. But few of the proposals have been adopted.

#### St. John's Centre - Planning '72 1972

This is a downtown residential development scheme. It was prepared by the People's Planning Programme. The scheme recommends a housing rehabilitation development for the central city.

#### Downtown Concept Plan - New Gover Street Complex 1972

This plan has been submitted to the Municipal Council. It was prepared by the Economic Development Committee of the St. John's Board of Trade. The Municipal Council have adopted the recommendations of the study. They have budgeted \$50,000 for the fiscal year 1973. Its purpose is to provide a full-time development commissioner and organization.

#### Report to the City Council 1972

This was the formal report by the independent commissioner conducting public hearings on Plan 91. The Commissioner for those public hearings was John J. Murphy. The hearings were held in April, 1972. Up to May, 1973 the Municipal Council had taken no action on the recommendations of the Commissioner.

#### Preserving Historic St. John's 1972

This was a brief to the Commissioner conducting the hearings into Plan 91. It was really a submission by a group called the Newfoundland Historic Trust. This is a non-profit organization of private citizens. They are concerned mainly with the preservation of the province's heritage. Included in the brief is an inventory of historic building areas in the city. As of May, 1973 the inventory and recommendations had not been acted upon.

(Our City in Conference, Appendix)

The majority of these proposals have been presented to the public for public hearings. In a number of cases public opinion was disregarded. Their recommendations were never



THOMAS W. LONG F.S.M.  
1940-41



DONALD JAMES ALDRICH K.C.  
1940-41



WILLIAM ELLIS  
1900-01



SIR TASKER COOK K.C.  
1941-42



WILLIAM GOSLING  
1942-43



CHARLES HOWLETT D.D.S.  
1943-44



ANDREW G. CARSELL C.B.I.  
1944-45



HENRY G. NEWS F.R.S.



WILLIAM ADAMS Q.C.



Mayors Of St. John's. Do You Think Mayor Adams Will Be The Last Mayor Of His Kind In St. John's? Discuss.

acted upon. For example, in 1972 the Newfoundland Historic Trust made a request to the public hearings on Plan 91. (Plan 91 is the 20 year master plan which the Municipal Council had prepared by a group of consultants.) The Historic Trust group recommended that historic parts of St. John's be preserved. The recommendations have never been acted upon by the Council. Recommendations were also made by the Commissioner of Public Hearings on Plan 91, John J. Murphy, who is now the deputy mayor. These were not acted upon.

Many reasons exist for public opinion being disregarded. Some of these reasons were made public during the "Our City in Conference" held in May 25-27, 1973. This was really a public forum for the discussion of city problems. One of the reasons given for the disregarding of public opinion was the type of mayor in office. Mayor Adams (1965-73) is thought to have ruled the city with an iron hand. He made many major decisions himself. These decisions concerned city government as well as development. A change in attitude on the part of the city officials was needed. Boyce Richardson stated at the city conference: "Mayor Adams is the last mayor of his type that St. John's will ever know." (Telegram, May 20, 1973) Needless to say in November, 1973, Adams was voted out of office. He has been replaced by a reform conscious mayor. The new mayor says she will listen to public opinion. In her first four years as a councillor Dorothy Wyatt proved this. She did keep in contact with public issues and problems. She held public meetings at various locations throughout the city. Usually these meetings were at her own expense. In November, 1973, Mrs. Wyatt was elected as the first woman mayor of St. John's.

Many of the city elders were appalled at the idea of a woman mayor. However, their opinions gradually seemed to change. Mrs. Wyatt promised a more public aware council. She would have nothing to do with private council meetings. If elected she would act as a full-time mayor. With such ideas she won the hearts of the electorate. In January, 1974, she became the city's leading father (mother?) It remains to be seen, however, whether all her promises will be carried out. The people of the city hope they will get the reform government for which they have been looking. But already in Mayor Wyatt's first year of office, 1974, trouble has been brewing. Three of the professional planners with the city council have resigned. A controversy over the erection of a Triset Complex appears to have caused these resignations. It seems that the plans were not referred to the city planning office. Approval was first given by Mayor Wyatt and the Councillors.

(Telegram, July, 1964)

1. Why would city elders be appalled at having a woman mayor?
2. Was your last city council (or town council) elected on a reform ticket? If so, what reforms were proposed? Would these reforms be good or bad for your area?
3. Do you think Mrs. Wyatt will keep her promises? Why or why not?
4. Boyce Richardson, an author and journalist from Montreal, described St. John's as "a jewel in the tundra of diversity that makes Canada different from other countries." Write an essay describing what you think he meant by that statement. (Our City in Conference 1973 report)

#### Controversies Directly Related to Housing

In this section we will look at current

controversies which have an affect on housing, a growing population.

About three years ago while Mayor Adams was in office, a new project was introduced for downtown St. John's. Since then there has been much opposition to these plans. In fact, it dominates the city newspapers. This project is an intended Arterial Road. This road is supposed to run from the Trans Canada Highway to downtown St. John's. Almost every part of St. John's Society have given opinions on the new road. Home owners, members of the Historic Trust, downtown business men, people who are thinking of the environment have all expressed opinions on it. Much of the debate has centered around the effects of such a road on the city.

In the sixties, plans were made to bring back life to the old section of the city. In 1972 Plan 91 was introduced to the public. In this plan, Arterial Roads were shown to be very important. Such roads would help solve the heavy traffic problem throughout the city. At present, for example, large transport trucks can only enter the city at two points. One of these is the T.C.H. at Kemmount Road. By means of a grant from the Federal Government Department for Regional Economic Expansion (DREE), work began on the new Arterial Road. Some people at one saw this as a great boom for downtown business. Then, however, the opposition began. People interested in the environment pointed out the dangers to the ecology. The route they said would have to be cut through virgin forests and lands. People who live on the Southside Road became aroused. Many of their homes would have to be lost to make way for the new road.

The Historic Trust brought up an important question. Which buildings, they asked, would be affected by this new Arterial? All of this resulted in the question which has dominated the





What Problems Of A Culture In Transition Do You Think Are Evidenced In These Pictures?

news in the past months. That question is - "Where will the Arterial enter the already congested downtown area?" The question remains still unanswered.

The above is only a summary of the major points talked about in the controversy. However, as Richardson (Telegram May 29, 1973) said "people get the kind of cities they deserve and the only way to get better cities is for people to find a way of making their opinions about city development known." For the time being, work on the Arterial has stopped. The road is connected to the city via the Goulds Road in Kilbride. There is question whether or not it will progress any farther.

1. Write an essay taking a stand either for or against the completion of the Arterial Road to downtown St. John's.

2. Look at a map of the city and decide where you would have the road enter. Why?

3. Has an arterial road recently been built into your community?

a) If so, will this route be beneficial or harmful to the community? Why?

b) If not, do you think an arterial road should be built into your community? Why or why not?

4. How would the building of an arterial road affect housing?

#### Activity Section (Things To Do)

##### Activity I

A. Study the pictures shown on the opposite page. What problems of a culture in transition do you see in these pictures?

B. Organize a group to take pictures in your community. Take one of the following themes for your photo study.

- a) old blending with new
- b) problems of a changing lifestyle
- c) types of housing

##### Activity II

Form a group to go to your community planning office or write to your provincial government to obtain information on the master plan for development in your area.

##### Activity III

Form groups to discuss and plan a dramatization of a group of irate citizens who are upset over some public controversy. Appoint one member of the group to present your complaints or demands to the class.

##### Activity IV

EITHER: Invite a city planner to come and give a talk on the role of a city planner.

Prepare a list of questions which you would like to have him answer.

OR: Prepare and arrange an interview with a city planner.

##### Activity V

1. Make an inventory of all the buildings of historic interest in your community.

2. Arrange with your teacher to go on a field trip to take pictures of those buildings.

3. Make a TV box and prepare a show of.

- a) the buildings which are being preserved
- b) the buildings which are going to be demolished in the near future.

4. Go to your local library and find pictures of buildings that used to exist in your community but are now destroyed. Make a list of these and tell why they were destroyed.

##### Activity VI

Prepare and record a radio broadcast from the scene of some public issue which is very much

in the news today.

##### Activity VII

Prepare a bulletin board display depicting the history of your community in pictures.

##### Activity VIII

You have the possibility of creating an ideal community.

- a) What things must you keep in mind in developing your community.
- b) Describe the community you wish to develop.
- c) How will you people it?
- d) What transportation and communication facilities have you provided?
- e) Make a model of your ideal community.

##### Activity IX

1. Make a list of various problems of providing housing accommodations in a city.
2. Prepare a questionnaire and conduct a survey in your community to find out what housing problems exist. Write up a report of your findings.

##### Urban Areas

In my beginning is my end. In succession Houses rise and fall, crumble, are extended. Are removed, destroyed, restored, or in their place

Is an open field, or a factory, or a by-pass. Old stone to new building, old timber to new fires,

Old fires to ashes, and ashes to the earth. Which is already flesh, fur and faeces. Bone of man and beast, cornstalk and leaf. Houses live and die; there is a time for building

STOP, LOOK AND INQUIRE

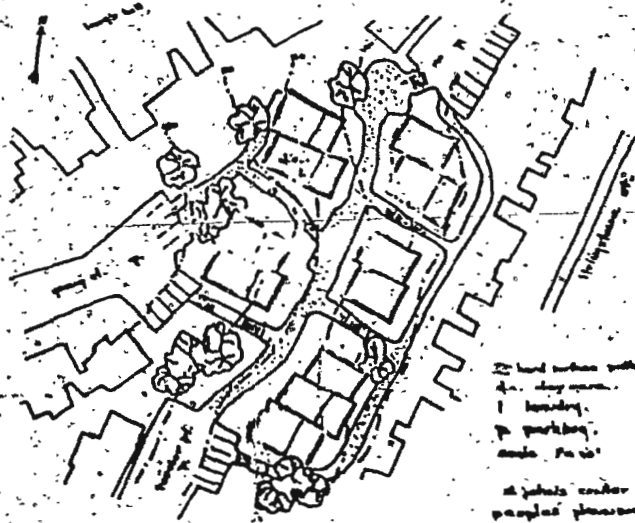

St. John's Center Planning People's Planning Program Proposal For Infill Housing August, 1972.

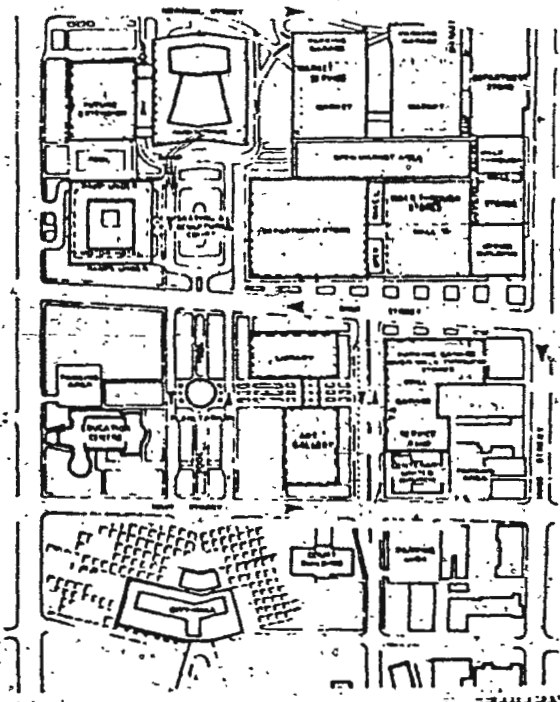

The Above Map Shows The Redevelopment Plan For An Area Of Hamilton.



And a time for living and for generation.  
And a time for the wind to break the loosened  
pane:  
And to shake the wainscot where the field-  
mouse crots  
And to shake the tattered areas woven with a  
silent motto.

Item 47. East Coker (URBAN AREAS by Eric Winter  
Scarborough, Ontario: Bellhaven House, 1971)

1. What do you think the poet is trying to say  
in this poem?
2. Is the situation presented in this poem  
similar to anything in your community? Give  
examples.
3. What do you think the poet means by  
"Houses live and houses die"?
4. Do you think houses should be allowed to  
die? Give reasons for your answer.
5. Give an appropriate title for this poem.

---

Urban Areas (continued)

Look at the two diagrams on the opposite page.

1. Do you see any similarities? Any  
differences? List them.
2. If you had to redevelop one of these areas,  
how would you go about it? In your answer  
be sure to include what you would destroy,  
what you would renovate, what you would save  
and give your reasons for each decision.

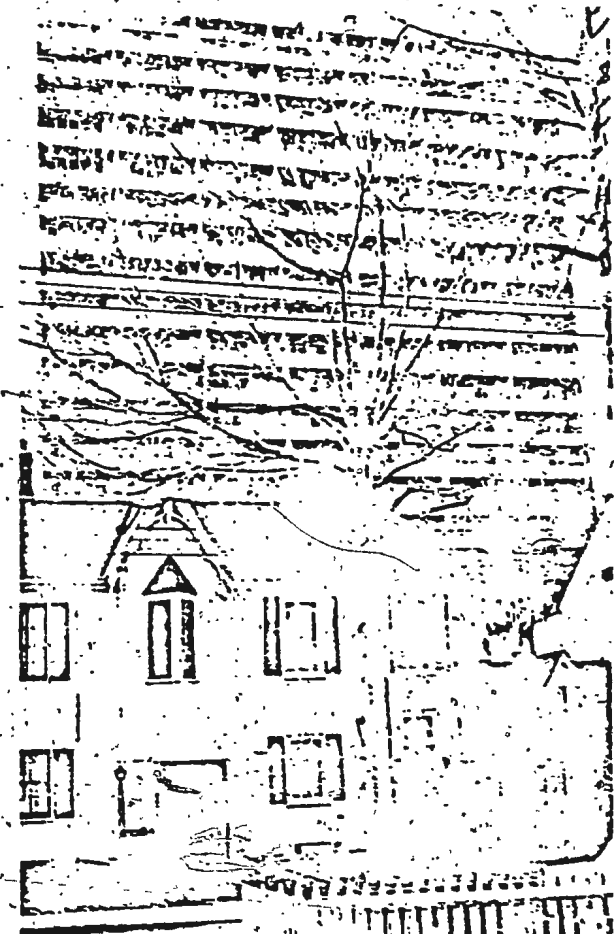

Write a story about what you think this  
house in Toronto is thinking about the new  
developments in the area. In your story be  
sure to include the following:

- a) what life may have been like when the  
house was new.
- b) the effect age is having upon the house.
- c) how the house feels about these new  
developments and the disappearance of things  
that were familiar to it.

NOTES ON WHAT I HAVE LEARNED ABOUT MY COMMUNITY

In this unit you have been presented with some of the problems that exist in an old city which finds itself in the process of change. This change is due to many factors but perhaps the most common are an increase in new industry, and a continually growing population. You have also looked at many of the problems which exist in planning the expansion of a growing city. You have looked at the problems in the city of St. John's and compared them with similar examples from other cities in other areas of Canada. As a result of such studies it should be apparent that urbanization has both advantages and disadvantages. It would be interesting to follow this topic with similar studies on other large urban areas in Canada. Would our findings show that Canada is rapidly becoming an "urbanized country?"

Questions for discussion:

1. What do you think of large, growing cities? Is this good or bad? Discuss.
2. a) How important is planning?  
b) When should planning be done?  
c) What can be done when planning in the past has been poor or non-existent?
3. From what you have learned write a short essay about your own community. Is it becoming a growing urban center? Discuss whether you think this is a good or a bad thing for your town.

NOTES ON WHAT I HAVE LEARNED ABOUT MY COMMUNITY

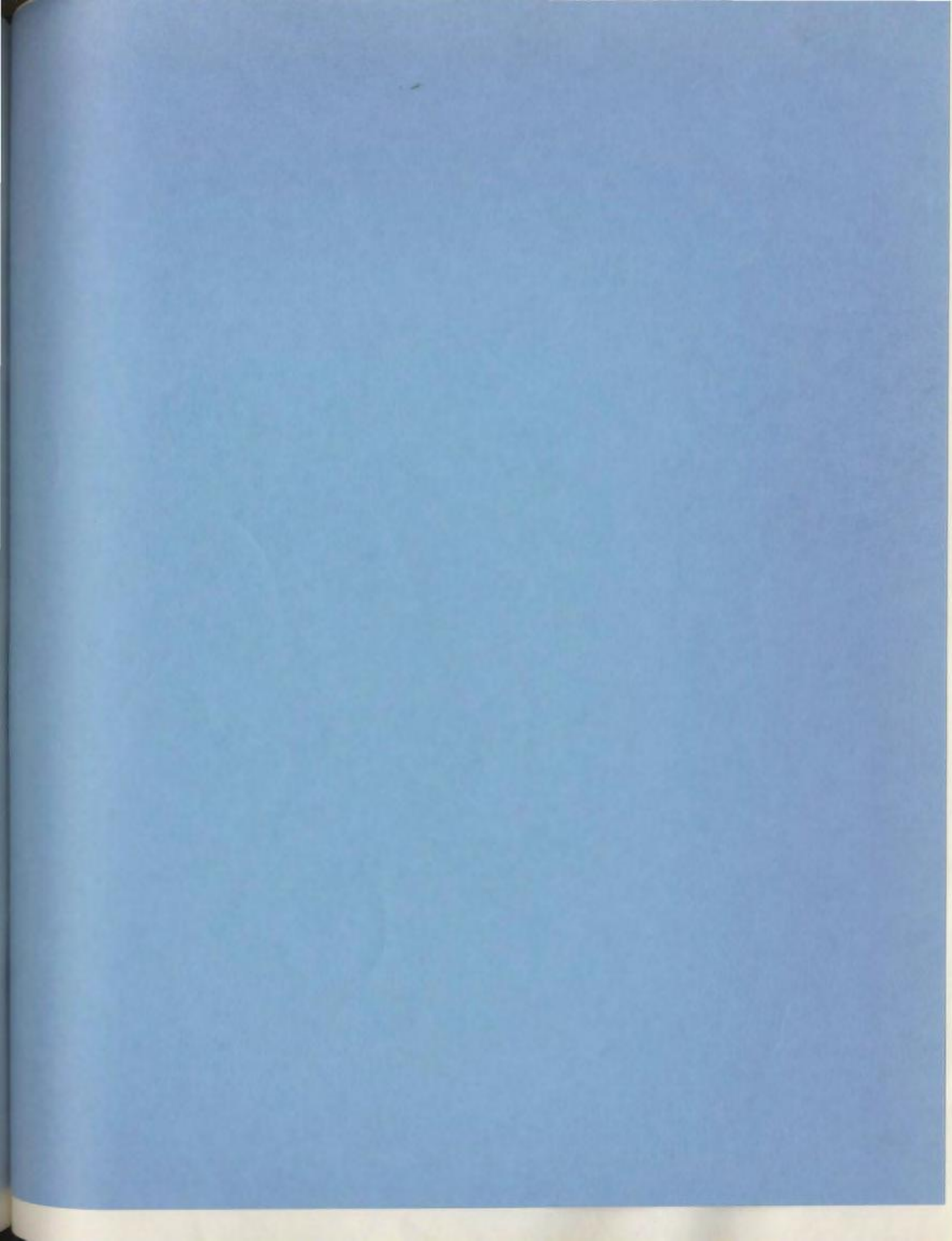

Appendix B

Teacher's Guidebook

CANADA STUDIES FOUNDATION

PROJECT ATLANTIC CANADA

St. John's Project

TEACHER GUIDEBOOK

for

Culture in transition: Problems of a changing lifestyle

ST. JOHN'S PROJECT

TEAM PERSONNEL

Patricia M. Connolly

Frederick T. Butler

Malcolm B. Squires

Bramwell Dawe

CURRICULUM DEVELOPMENT CONSULTANT

Dr. Robert M. Anderson  
Department of Curriculum and Instruction  
Memorial University of Newfoundland



## RATIONALE FOR ST. JOHN'S PROJECT

### Culture in transition: Problems of a changing lifestyle

It has often been said that, ever since the days of the fishing admirals, the people of Newfoundland have developed a unique lifestyle, one that has retained much of the flavour of the Old World while at the same time forming a decided character of its own. Over the years the word "Newfoundlander" has oft times conjured up in the mind of the listener a stereotyped picture of weather-beaten, hard-working fisherfolk, lovers of a simpler life, or, to use a more common phrase, people living in harmony with nature.

"We'll rant and we'll roar like true Newfoundlanders" say the lyrics of the folksong. But what exactly is a "true" Newfoundlander? Are all Newfoundlanders in fact sharers of the same culture? Is the Newfoundlander of today the same as the Newfoundlander of bygone days?

The establishment of an accurate picture of a Newfoundland "culture," if, in fact, there can even be said to be one unique culture, is most definitely a monumental task, one that is unfortunately quite beyond the scope of the topic of this project. The province is composed of many lifestyles. Some have remained relatively unchanged through the passage of time; others however, have become deeply affected by "modern living" and all that the term implies.

The city of St. John's can be said to belong to the latter category. For centuries it supported a social and cultural life which in many ways remained virtually unchanged. In many ways life in St. John's was also quite different from that of other areas in Newfoundland: Perhaps it can be said that there existed a lack of communication, not only with other parts of North America but also with other areas of the island itself. This lack of communication would,

therefore, be a factor in the development of the lifestyles of individual communities; lifestyles which in many cases have resisted change or outside interference of any kind until recent years.

St. John's is an area which is experiencing a type of cultural transition. Here remnants of what was are still very much in evidence, existing side by side with the lifestyle of the "modern" Newfoundlander. With each succeeding generation, however, St. John's is losing much of what were once thought to be unbreakable traditions and unchanging values. And, as is perhaps to be expected, this cultural transition is presenting many problems. Many people are contented with the new ways; others, however, mourn the loss of what they consider to be their cultural identity, their uniqueness, their traditions which were so deeply cherished by their parents and grandparents.

The St. John's team, therefore, as part of Project Atlantic Canada, and keeping in mind the PAC theme of Regionalism and Cultural Diversity, is attempting to study the city of St. John's as an area of cultural diversity which is undergoing a process of change, and the problems which have come about as a result of this cultural change.

This project is in keeping with the criteria of the Canada Studies Foundation. The topic is one which, though deeply rooted in the past, is noticeably affecting the present, and will, undoubtedly in many ways, affect the cultural future of the city. It is most definitely a topic which is very much alive in Canada as a whole today. An awareness of the diversity that helps to comprise the nation of Canada is vital to an understanding of Canada as a whole. Many areas of this country are experiencing similar problems of cultural transition -- the Atlantic provinces are perhaps a good example. On a much

larger scale can be found those problems which are being experienced by the native peoples of this country. The St. John's Project is therefore a regional illustration of a topic which is both contemporary and nationally significant.

#### GENERAL INTENDED LEARNING OUTCOMES

1. Knowledge. The student should be able:
  - a) to show an understanding of the concepts of culture, diversity, and transition;
  - b) to show an understanding of the meaning of cultural diversity;
  - c) to specify some problems of a "cultural transition";
  - d) to show how the lifestyles of the St. John's people are influenced by a multitude of factors;
  - e) to make general comparisons between St. John's and other Canadian urban centres;
  - f) to make cultural comparisons between urban areas and rural areas;
  - g) to trace the history of urban growth in the city of St. John's;
  - h) to recognize the many facets of public controversy to which they are exposed;
  - i) to show how geography plays an important role in urbanization;
  - j) to recognize the trend in Canada towards urbanization.
2. Techniques. The student should be able:
  - a) to demonstrate ability to work with primary and secondary sources, if only on a limited scale;

- b) to gather, organize, and critically analyze data;
- c) to establish a frame of reference and to work within that frame of reference;
- d) to demonstrate the ability to work with maps, contour maps, charts, tables, and graphs;
- e) to demonstrate skill in the use of interviewing techniques;
- f) to show an ability to utilize a camera effectively in the development of a theme;
- g) to interpret photographs to find answers to questions;
- h) to work effectively as a member of a group;
- i) to dramatize issues of great interest;
- j) to demonstrate skill in arranging an effective bulletin board display centered around a given theme;
- k) to develop a questionnaire and conduct a survey if only on a limited scale;
- l) to demonstrate ability to role-play;
- m) to debate effectively issues of great controversy.

3. Values and Attitudes. The student should be able:

- a) to show understanding for and appreciation of different lifestyles;
- b) to make sound judgements regarding the value of modernization and its effects on lifestyles;
- c) to show an appreciation for his own culture, and to see it as part of the Canadian identity;

- d) to weigh the pros and cons of a problem situation, take a stand and support it;
- e) to internalize attitudes dealing with the problem situations presented in the narrative;
- f) to express respect and tolerance of diversity.

CRITERIA FOR SELECTION OF  
GENERAL INTENDED LEARNING OUTCOMES

Since the publication of What Culture? What Heritage? (Hodgetts, 1968), teacher initiative in curriculum development has become a burgeoning phenomenon in Canada (Anderson and Roald, 1973). Teachers all across Canada have come to realize a need for involvement in the development of curricula in Canada studies relevant for their own and other Canadian classrooms (Massey, 1971; Tomkins, 1972; C.S.F. Annual Report, 1973). It is through this teacher-initiated curriculum development that teachers involved in Canada Studies Foundation Projects have been working on projects that reflect the major organizing principle of the Canada Studies Foundation "continuing Canadian concerns" (Tomkins, 1972).

According to Anderson (1973), a Canada Studies Foundation project director for Project Atlantic Canada, Newfoundland and Labrador, when work begins on developing units by an individual team, it is then the responsibility of the members to develop materials based on the following criteria:

1. A series of curriculum and instruction units developed and evaluated largely by practicing teachers.
2. Materials developed from a regional viewpoint.
3. Materials of national significance.
4. Materials interchangeable across Canada.
5. Materials which encompass all grade levels.

6. Materials to be inserted as a unit of an existing course, or combined into a full course.
7. Materials that are interdisciplinary in nature.
8. Materials that are supported by multi-media materials.
9. Materials that deal with controversial issues.
10. Materials that present differing points of view.
11. Materials that contain inquiry-oriented and expository materials.
12. Materials that stress empathy for all individuals and multiple loyalties.

(Anderson, 1973, p: 13)

The above-stated criteria were utilized by the St. John's team to enable them to develop the booklets in this project.

#### INSTRUMENTAL CONTENT

##### A. Ten student booklets as follows:

- \*I. Introduction to "Culture in transition"  
(prerequisite to all other booklets listed below)
- \*II. The beginnings of St. John's  
(prerequisite to any booklet listed below)
- \*III. Problems of a changing social lifestyle  
(geared to 5-6)
- \*IV. Problems of housing and planning in a growing urban centre  
(geared to 7-8)
- V. Problems of sociological interaction in a growing urban centre  
(geared to 5-6)

\*Units which have been developed as of June, 1975.

- VI. Problems of policing a growing urban centre  
(geared to 7-8)
  - VII. Problems of economics in a growing urban centre.  
(geared to 7-8)
  - VIII. Problems of governing a growing urban centre  
(geared to 7-8)
  - IX. Problems of communication in a growing urban centre  
(geared to 5-6)
  - X. Problems of transportation in a growing urban centre  
(geared to 5-6)
- B. Teacher Guidebook
- C. Multi-media resource kit

#### SUGGESTED TEACHING STRATEGIES

It is the intent of the developers that the teacher be given as much freedom as possible in utilizing his or her own creative talents in the teaching of these booklets. Therefore, the following teaching strategies are to be considered only as recommendations. It is entirely left to the individual teacher to use any or all of the following proposed teaching strategies. If the teachers of these booklets discover any other way to effectively teach these units, the developers will warmly welcome all comments.

1. Inquiry/discovery techniques
2. Group discussion
3. Independent study techniques
4. Lecture

### RELATED ACTIVITIES

The suggested activities in these booklets are based on the idea that students can learn a great deal by being actively involved in the learning process. Each of the activities in the booklets is designed for students to discover for themselves various aspects of Culture in transition: Problems of a changing lifestyle. It is anticipated that through these activities students will learn to look at the many elements which have to be considered in any public controversy. It is left for the individual teacher to choose the activities which he or she feels will best aid in achieving the intended learning outcomes for each of the booklets.

### RATIONALE FOR QUESTIONING TECHNIQUES

The questioning techniques incorporated in each of the booklets were utilized to stimulate inquiry and discovery in the classroom environment. The developers wish to inform the teacher that the nature of the questioning in these units provide for many interpretations of a question. It is the intention of the developers that the teacher encourage various explanations as possible answers. It is anticipated that the teacher will present any solutions which are not discovered by the student to ensure that the student will be exposed to all sides of an issue and eventually be forced to take a stand for himself.



Booklet One: Introduction to "Culture in transition"

DESCRIPTION

This short booklet is to be used as an introduction to the material contained in the project Culture in transition: Problems of a changing lifestyle. It has as its primary purpose the introduction of basic concepts such as culture, diversity, and transition which are necessary to the programme as a whole. The actual material presented is intentionally brief; it is not intended that it be an end in itself, but rather than it be used to stimulate class discussion, to create an awareness in the students of the cultural diversity which exists in Canada today. It is recommended by the project developers that this booklet be completed in a maximum of two class sessions; however, if the teacher feels that the specific needs of his or her class warrant a more thorough approach to this aspect of the topic, it should be carried out as needed. This project hopes to encourage teacher creativity as well as student creativity.

SPECIFIC INTENDED LEARNING OUTCOMES

1. Knowledge. The student should be able:
  - a) to show an understanding of the concepts of culture, diversity and transition;
  - b) to show an understanding of the meaning of cultural diversity;
  - c) to give other examples of cultural diversity as it exists in Canada today;
  - d) to discuss problems of a "cultural transition".
2. Techniques. The student should be able:
  - a) to establish a frame of reference and to work within that frame of reference;

b) to work effectively as a member of a group.

3. Values and Attitudes. The student should be able:

- a) to show understanding for and appreciation of different lifestyles;
- b) to show an appreciation for his own culture, and to see it as part of the Canadian identity;
- c) to express respect and tolerance of diversity.

\*\*\*\*\*

Booklet Two: The beginnings of St. John's

DESCRIPTION

This booklet is to be used as a prerequisite for any other booklet in the project. It differs in format, however, from any of the remaining booklets in that it is intended to be expository in nature rather than problem-centered and inquiry-oriented. Its primary purpose is to provide students with general historical background information, and with background information on early St. John's history. It is hoped that the data provided will help students to understand St. John's reason for being, thereby helping to promote a better understanding of that project material which is to follow. It is the wish to the project developers that very little emphasis be placed on the memorization of places, names, or dates, as this would, in the opinion of the writers, defeat one of the main purposes of the project. The attention of the teacher is also directed to the slide-tape presentation which is included. This slide tape should help to provide a setting for the material contained in this part of the programme, as it shows many of the historic and the modern aspects of St. John's thereby presenting it as an example of culture in transition.

## SPECIFIC INTENDED LEARNING OUTCOMES

1. Knowledge. The student should be able:
  - a) to discuss the meaning of the terms continental shelf, fishing bank, contour map, contour lines;
  - b) to give reasons for voyages of exploration in the fifteenth and sixteenth centuries;
  - c) to discuss the importance of fishing to European countries during this time;
  - d) to give reasons why Newfoundland became an important "stopping-off" place for European fishermen;
  - e) to show how geography played an important role in early settlement;
  - f) to specify reasons why settlement was discouraged rather than encouraged in Newfoundland in general;
  - g) to compare and contrast early settlement in Newfoundland with early settlement in other parts of Canada;
  - h) to give reasons why areas of settlement in Newfoundland became isolated from one another;
  - i) to relate factors which influenced the early development of St. John's;
  - j) to show how St. John's became important as a trading area;
  - k) to discuss early attempts at fortifying St. John's against enemy attack;
  - l) to display knowledge of the early French-English battles in St. John's;
  - m) to describe early social life in St. John's;
  - n) to describe the first attempts at forming civic government in St. John's;
  - o) to discuss reasons for the growth of St. John's;
  - p) to tell how contact with Europe greatly influenced the lifestyles of early St. John's.

2. Techniques. The student should be able:
- a) to give evidence of being able to work with contour maps;
  - b) to interpret maps and pictures to find answers to questions;
  - c) to work with diagrams to find answers to questions;
  - d) to work effectively as a member of a group.
3. Values and Attitudes. The student should be able:
- a) to show understanding for and appreciation of different lifestyles;
  - b) to show an appreciation for his own culture, and to see it as part of the Canadian identity.

\*\*\*\*\*

Booklet Three: Problems of a changing lifestyle

DESCRIPTION

This booklet presents St. John's as an area which is experiencing many changes in social lifestyles. As the business centre for the island of Newfoundland, St. John's was always in close contact with Europe for it was the meeting place for European trading vessels. As such, it became very European in its social lifestyles, an influence which was reflected in numerous facets of its everyday living. In this way it was therefore often very unique. Gradually, however, St. John's began to experience a change, a transition, or to put it in more familiar terms, the effects of modernization. St. John's is becoming urbanized in the North American sense of the term, and the once strong European influences have quickly diminished. It can most definitely be said that St. John's is experiencing the effects of a changing social lifestyle.

In this booklet, Problems of a changing social lifestyle, the student is presented with a picture of this city in transition. Through comparison studies and the inquiry approach, the student is encouraged to view his own area, as well as other Canadian communities, in the same light, to investigate other lifestyles which may or may not be experiencing similar changes. The projects for student inquiry which are included have been devised by the project developers to aid the student in obtaining maximum benefit from this booklet. The reading level is suitable for the upper elementary level, or may be used at the junior high level, according to the needs of the individual class and the wishes of the individual teacher.

#### SPECIFIC INTENDED LEARNING OUTCOMES

1. Knowledge. The student should be able:
  - a) to describe the class structure of nineteenth century St. John's;
  - b) to describe upper class social life in nineteenth century St. John's;
  - c) to specify the role played by societies in nineteenth century St. John's;
  - d) to specify the role played by sports in St. John's society of the nineteenth century;
  - e) to compare the upper class social life in St. John's with that of his own community during the nineteenth century;
  - f) to describe lower class social life in nineteenth century St. John's;
  - g) to show how customs played a major role in the lifestyles of nineteenth century St. John's;
  - h) to describe the class structure of modern St. John's;
  - i) to give examples of the cultural life of modern St. John's;
  - j) to specify the role played by sports and recreation in modern St. John's;

k) to discuss the role played by general entertainment in St. John's society;

l) to discuss problems associated with a cultural and social transition.

2. Techniques. The student should be able:

a) to demonstrate ability to work with primary and secondary sources, if only on a limited scale;

b) to demonstrate skill in the use of interviewing techniques;

c) to show an ability to utilize a camera effectively in the development of a theme;

d) to interpret photographs to find answers to questions;

e) to work effectively as a member of a group;

f) to dramatize issues of great interest;

g) to demonstrate ability to role-play;

h) to debate effectively issues of great controversy.

3. Values and Attitudes. The student should be able:

a) to show understanding for and appreciation of different lifestyles;

b) to make sound judgements regarding the value of modernization and its effects on lifestyles;

c) to show an appreciation for his own culture, and to see it as part of the Canadian identity;

d) to weigh the pros and cons of a problem situation, take a stand, and support it;

e) to internalize attitudes dealing with the problem situations presented in the narrative;

f) to express respect and tolerance of diversity.

Booklet Four: Problems of housing and planning in a growing urban centre

DESCRIPTION

The booklet Problems of housing and planning in a growing urban centre was developed as a unit of the St. John's project of Project Atlantic Canada, Culture in transition: Problems of a changing lifestyle. It was decided by the team members that this unit could be developed based on the criteria of the Canada Studies Foundation which were previously outlined in this guidebook. We, the team members, are of the opinion that you will find this unit an effective and valuable experience for the students in your social studies classes. The reading level of this booklet is about level 7. Therefore, we anticipate that the booklet will be used most effectively with upper elementary students of above average ability and interest in social studies, or with average ability junior high school students. Following is an outline of the instrumental content of this unit.

1. background information on housing and planning in St. John's;
2. description of nineteenth century St. John's;
3. questioning on twentieth century St. John's;
4. recent developments in town planning in the city of St. John's;
5. controversies related to housing a growing population;
6. suggested activities to bring about an understanding of the terms "culture in transition" and "town planning";
7. comparative studies;
8. summary.

Furthermore, we, the developers, would like you to keep in mind the following general questions while using this booklet:

1. How important is planning?
2. When should planning be done?
3. What can be done when planning in the past has been poor or non-existent?
4. Do students have a grasp of the concepts of culture, transition and urban planning?
5. Can students be stimulated through this booklet to conduct a similar local study?

#### SPECIFIC INTENDED LEARNING OUTCOMES

1. Knowledge. The student should be able:
  - a) to list the advantages and disadvantages of home ownership;
  - b) to list the advantages and disadvantages of rented housing;
  - c) to compare home ownership with rented accommodations;
  - d) to describe nineteenth century St. John's;
  - e) to specify the effects urban renewal schemes have on older sections of a city;
  - f) to enumerate ways in which planning expansion for a city can be implemented;
  - g) to describe plans directly related to the growth of St. John's;
  - h) to give examples of great public controversy in the city of St. John's;
  - i) to compare the housing situation in St. John's with that in other Canadian cities;
  - j) to trace the history of urban growth in St. John's and other Canadian cities;
  - k) to describe the role of planning in a growing urban centre.



2. Techniques. The student should be able:

- a) to demonstrate skill in interviewing techniques;
- b) to show an ability to research using primary and secondary sources if only on a limited scale;
- c) to demonstrate the ability to work with maps, charts, and tables;
- d) to show an ability to utilize a camera effectively in the development of a theme;
- e) to interpret photographs and slides to find answers to questions;
- f) to work effectively as a member of a group;
- g) to dramatize issues of great public interest;
- h) to demonstrate skill in arranging an effective bulletin board display centered around a given theme;
- i) to develop a questionnaire and conduct a survey if only on a limited scale.

3. Attitudes and Values. The student should be able:

- a) to show an understanding of and an appreciation for the problems involved in town planning;
- b) to make sound judgements regarding the value of modernization;
- c) to understand the problems associated with trying to house a growing population;
- d) to become aware of the importance of a well-thought out plan for expanding a city's limits;
- e) to weigh the pros and cons of a problem situation, take a stand, and support it;
- f) to determine whether or not housing should be preserved for its intrinsic historic value;
- g) to internalize attitudes dealing with the problem situations presented in the narrative.

This programme presents a regional example of a nationally-significant problem, i.e., problems associated with changing lifestyles in culturally diverse areas.

The programme is problem-centered and inquiry-oriented.

Controversial issues are introduced with various view-points being presented.

Teacher creativity, as well as student creativity, is encouraged.

The student is encouraged to make comparison studies with other Canadian communities:

A variety of projects and activities is provided.

Each booklet is completely self-contained, i.e., it presents enough material for the adequate pursuit of the topic, independent of the other booklets.

Specific intended learning outcomes are provided for each booklet.

Whenever possible, primary sources are provided.

Each booklet is geared to a specific reading level, either at the upper elementary or junior high level.

The project material may be used as a programme in itself, or as supplementary materials for an already existing programme.

- Anspach, L. A. A history of the island of Newfoundland. London: T. & J. Allman, 1819.
- Brown, C. Death on the ice. Toronto: Doubleday, 1974.
- Byrnes, J. M. The paths to yesterday. Boston: Meador Publishing Co., 1931.
- Canada, Bureau of Statistics. Census of Canada, 1971.
- Careless, J. M. Canada: A story of challenge. Toronto: Macmillan, 1963.
- DeGobineau, A. Voyage a Terre-Neuve. Paris: Librairie de L. Machette et Cie, 1861.
- Devine, P. K. Ye olde St. John's 1750-1936. St. John's: The Newfoundland Directories, n.d.
- Financial Post. 1958-1971
- Harvey, M., & Hatton, J. Newfoundland: The oldest British colony. London: Chapman & Hall Ltd. 1883.
- Higgins, B. E. The port of St. John's. The Book of Newfoundland. Volume 4, 1967, pp. 85-88.
- Horwood, H. The traveller's Canada: Newfoundland. Toronto: Macmillan of Canada, 1969.
- House, J. D. Two lower class areas in St. John's: A comparative study. Unpublished bachelor's dissertation, Institute of Social and Economic Research, Memorial University, 1964.
- Housing J. Paper presented on housing. November 19-21, 1972.
- Jukes, J. B. Excursions in and about Newfoundland during the years 1839 and 1840. London: William Clowes & Sons, 1842. 2 vols.
- Mann, W. E. Social and cultural change in Canada. Vancouver: Copp Clark, 1970.
- Matthews, K. A history of the West of England-Newfoundland fisheries. Unpublished doctoral dissertation, University of Oxford, 1968.
- McCrea, R. B. Lost amid the fogs: Sketches of life in Newfoundland. London: Sampson, Low, Son, & Marston, 1869.
- Mowatt, F. Newfoundland: "T'ree hunnert year gone by". New York: St. Martin's Press, 1971.

Murphy, M. P. Garrison days in St. John's. Atlantic Guardian. September, 1957, 10-11, 17-18.

Newfoundland Department of Municipal Affairs and Supply, Provincial Planning Office. St. John's metropolitan area municipal plan, St. John's, 1966.

Newfoundland Historic Trust. Preserving historic St. John's; Submitted to the public commissioner on Plan 91. St. John's 1972.

\_\_\_\_\_. Brief submitted to the St. John's Municipal council and planners. St. John's, 1969.

People's planning programme, St. John's, Newfoundland. St. John's Centre - planning 1972, St. John's, 1972.

Perlin, A. B. St. John's: Newfoundland's ancient capital takes on new dimensions. The Atlantic Advocate. June, 1960, 37-50.

\_\_\_\_\_. The story of Newfoundland. Grand Falls: Anglo-Newfoundland Development Co., Ltd., 1959.

Proctor and Redfern Ltd., St. John's and Patterson Planning and Research Ltd., Toronto. St. John's Urban Region Study. St. John's, 1973.

Project Planning Associates, Ltd. Blackhead, St. John's urban renewal scheme, residential standards and rehabilitation, Final Report, Toronto, 1966.

\_\_\_\_\_. City of St. John's, Newfoundland, urban renewal study. Prepared for municipal council, Toronto, 1961.

Prowse, D. W. The St. John's fire of 1892. The Newfoundland Quarterly. Summer, 1962, pp. 7-10.

Rothney, G. O. Newfoundland: A history. Ottawa: The Canadian Historical Association, 1964.

Rowe, F. W. The development of education in Newfoundland. Toronto: Ryerson Press, 1964.

Royal Gazette. 1816-1818, 1828-1835, 1838-1839, 1842-1855.

Smallwood, J. R. (Ed.) The book of Newfoundland. St. John's: Newfoundland Book Publishers Ltd., 1937-1967. 4 vols.

Sponsored by the extension service, MUN. In cooperation with Central Mortgage and Housing Corporation, Ottawa. Our City in Conference. Sept. 1973.

St. John's Daily News: 1894-1896, 1898-1974.

St. John's Telegram. 1878, 1880-1886, 1888, 1890-1974.

Tocque, P. Newfoundland, as it was and as it is in 1877. Toronto: John B. Magurn, 1878.

Willson, B. The tenth island. London: G. Richards, 1897.

Appendix C

Rating Scales for Validation of Programs (RSVP)

(Weiss, 1972)

RATING SCALES FOR THE VALIDATION OF PROGRAMS (RSVP)

INSTRUCTIONS TO JUDGES

This instrument contains pools of statements about clarity, appropriateness, enjoyment, worth and consistency of various aspects of the curriculum program under study. Each statement is assigned a number for identification purposes.

You are asked to state the extent of your agreement with each statement by circling the appropriate letter on the right side of the page according to the following criteria :

- fully agree                    a
- agree                                    b
- disagree                                c
- strongly disagree                    d
- not applicable                            e

If you would like to elaborate upon your response please do so under the comment section on the extreme right side of the page.

SECTION I : CLARITY OF THE PROGRAM

The following set of items concerns how CLEAR the developers have specified certain aspects of the program :

	<u>R A T I N G</u>	<u>C O M M E N T S</u>
	a   b   c   d   e	
1. The subject matter is clearly stated.	a   b   c   c   e	
2. The age range and/or the grade level of learners are clearly stated.	a   b   c   d   e	

	<u>R A T I N G</u>					<u>C O M M E N T S</u>
	a	b	c	d	e	
3. The level of intelligence of learners is clearly stated.	a	b	c	d	e	_____
4. The geographic area of students is clearly stated.	a	b	c	d	e	_____
5. The social class of students is clearly specified.	a	b	c	d	e	_____
6. The reading level (grade level) of learners necessary for this program is clearly stated.	a	b	c	d	e	_____
7. The learners' prior experiences with the subject matter are clearly stated.	a	b	c	d	e	_____
8. The prerequisite writing ability (written expression or handwriting) of students is clearly specified.	a	b	c	d	e	_____
9. The required language of the students is clearly specified.	a	b	c	d	e	_____
10. The mathematics' prerequisites of the learners is clearly stated.	a	b	c	d	e	_____
11. The learners' prerequisite attitudes are clearly stated.	a	b	c	d	e	_____
12. The students' interests are clearly specified.	a	b	c	d	e	_____
13. The prerequisite physical or psychomotor attributes of learners are clearly stated.	a	b	c	d	e	_____

R A T I N G

C O M M E N T S

a b c d e

14. The students' prerequisite emotional attributes are clearly specified.

a b c d e

\_\_\_\_\_

15. The prerequisite cultural background of learners is clearly stated by the developers.

a b c d e

\_\_\_\_\_

16. The teacher training experiences for teaching this program are clearly stated.

a b c d e

\_\_\_\_\_

17. The teachers' knowledge of this specific subject matter is clearly outlined.

a b c d e

\_\_\_\_\_

18. The interests of the teachers are clearly outlined.

a b c d e

\_\_\_\_\_

19. The teachers' prerequisite attitudes for this program are clearly specified.

a b c d e

\_\_\_\_\_

20. The teachers' relevant experiences with audio-visual devices are clearly stated.

a b c d e

\_\_\_\_\_

21. The relevant experiences of teachers with instructional techniques utilized in the program are specified clearly.

a b c d e

\_\_\_\_\_

22. The teachers' relevant experiences with the type of students who take part in this program are clearly specified.

a b c d e

\_\_\_\_\_

23. The teachers' prerequisite preferences for subject matter content are clearly stated.

a b c d e

\_\_\_\_\_



	<u>R A T I N G</u>	<u>C O M M E N T S</u>
	a b c d e	
24. The teachers' preferences for methods of organizing material are clearly stated for this curriculum program.	a b c d e	_____
25. The teachers' preferences for particular roles of the teacher are clearly specified for this program.	a b c d e	_____
26. The teachers' preferences for specific types of students are clearly specified for this program.	a b c d e	_____
27. The assumptions of how learning should take place are clearly outlined by developers.	a b c d e	_____
28. The assumptions of how teachers should teach this program are clearly stated by developers.	a b c d e	_____
29. The assumptions of the importance of the subject matter field for this curriculum are clearly stated.	a b c d e	_____
30. The assumptions of the importance of specifying objectives for this program are clearly stated.	a b c d e	_____
31. The general or global objectives for this program are clearly specified.	a b c d e	_____
32. The specific objectives for this program are clearly stated.	a b c d e	_____

	<u>RATING</u>					<u>COMMENTS</u>
	a	b	c	d	e	
33. The guidelines provided for determining the program's activities are clearly stated.						_____
34. The locations of classes or instructional areas for this curriculum program are clearly stated.						_____
35. The physical arrangements (groupings) of students are clearly specified.						_____
36. The time requirements for the completion of the program are clearly stated.						_____
37. The order of presentation of the activities is clearly stated by the developers.						_____
38. The order of presentation of the materials to be used in this program is clearly outlined.						_____
39. The rationale for the sequence given in the presentation of activities and materials is clearly stated.						_____
40. The teaching methods for this program are clearly specified.						_____
41. The teachers' roles are clearly stated.						_____
42. The aspects of the program to be evaluated during the planning phase are clearly stated.						_____

	<u>R A T I N G</u>	<u>C O M M E N T S</u>
	a b c d e	
43. The aspects of the program to be evaluated during the try-out are clearly stated.	a b c d e	<hr/>
44. The aspects of the program to be evaluated after the adoption in classes are clearly stated.	a b c d e	<hr/>
45. The evaluation procedures to be used during the planning phase of the program are clearly stated.	a b c d e	<hr/>
46. The evaluation procedures to be used during the try-out of the program are clearly stated.	a b c d e	<hr/>
47. The evaluation procedures to be used after the adoption of the program in classes are clearly stated.	a b c d e	<hr/>
48. The persons who develop or acquire the evaluation procedures for the planning phase of the program are clearly stated.	a b c d e	<hr/>
49. The persons who develop or acquire the evaluation procedures for the try-out of the program are clearly specified.	a b c d e	<hr/>
50. The persons who develop the evaluation procedures used after the adoption of the program in classes are clearly stated.	a b c d e	<hr/>
51. The persons who implement the evaluation procedures during the planning phase of the program are clearly stated.	a b c d e	<hr/>

	<u>R A T I N G</u>	<u>C O M M E N T S</u>
	a b c d e	
52. The persons who implement the evaluation procedures during the try -out of the program are clearly stated.	a b c d e	_____
53. The persons who implement the evaluation procedures after adoption of the program in classes are clearly specified.	a b c d e	_____

### SECTION II : APPROPRIATENESS OF THE PROGRAM

This set of items concerns the APPROPRIATENESS of certain aspects of the program :

54. The specific subject matter is appropriate to the learners age and / or grade level.	a b c d e	_____
55. The general background required for students is appropriate to the specific subject matter.	a b c d e	_____
56. The specific prerequisites for the students are appropriate to the specific subject matter.	a b c d e	_____
57. The prerequisites required of teachers are appropriate for teaching this program.	a b c d e	_____
58. The students' specific prerequisites are appropriate to their age range and/or grade level.	a b c d e	_____
59. The prerequisites of teachers are appropriate for teaching this age range and/or grade level of students.	a b c d e	_____

	<u>R A T I N G</u>	<u>C O M M E N T S</u>
	a b c d e	
60. The time limits for the completion of the program are appropriate for the students age range and/or grade level.	a b c d e	_____
61. The general objectives are appropriate for the grade level and/or the age range required for students.	a b c d e	_____
62. The specific objectives are appropriate for the required grade level and/or age range of students.	a b c d e	_____
63. The activities specified for this program are appropriate for the grade level and/or age range of students.	a b c d e	_____
64. The materials to be used in this program are appropriate for the age range and/or grade level of students.	a b c d e	_____
65. The conditions stated for this program are appropriate for the age range and/or grade level of students.	a b c d e	_____
66. The structure of the program is appropriate for the age range and/or the grade level of students.	a b c d e	_____
67. The teaching methods to be used are appropriate for the age range and/or grade level of students.	a b c d e	_____
68. The teacher's roles specified for the program are appropriate for the age range and/or grade level of students.	a b c d e	_____

	<u>R A T I N G</u>					<u>C O M M E N T S</u>
	a	b	c	d	e	
69. The evaluation procedures to be used are appropriate for this age range and/or grade level of students.						
70. The teachers' prerequisites are appropriate for student with the stated general background.						
71. The teachers' prerequisites are appropriate for students with the stated specific prerequisites.						
72. The general objectives are appropriate for and attainable by students who have the necessary general background.						
73. The general objectives are appropriate for and attainable by students who have the necessary specific prerequisites.						2
74. The specific objectives are appropriate for and attainable by students with the general background.						
75. The specific objectives are appropriate for and attainable by students with the specific prerequisites.						
76. The materials to be used are appropriate for students with the required general background.						
77. The materials to be used in this program are appropriate for students with the necessary specific prerequisites.						

	<u>R A T I N G</u>	<u>C O M M E N T S</u>
	a b c d e	
78. The activities to take place in the program are appropriate for students with the required general background.	a b c d e	<hr/>
79. The activities to take place in the program are appropriate for students with the specific pre-requisites.	a b c d e	<hr/>
80. The way this program is structured is appropriate for students with the stated general background.	a b c d e	<hr/>
81. The way this program is structured is appropriate for students with these specific prerequisites.	a b c d e	<hr/>
82. The teaching methods specified for this program are appropriate for students with this general background .	a b c d e	<hr/>
83. The teaching methods stated for this program are appropriate for students with these specific prerequisites.	a b c d e	<hr/>
84. The basic assumptions which underlie the curriculum program are appropriate for students with the required general background.	a b c d e	<hr/>
85. The basic assumptions which underlie the program are appropriate for students with these specific prerequisites.	a b c d e	<hr/>
86. The evaluation procedures to be used in the program are appropriate for students with the stated background.	a b c d e	<hr/>

	<u>R A T I N G.</u>	<u>C O M M E N T S</u>
	a b c d e	
87. The evaluation procedures to be used are appropriate for students with the necessary specific prerequisites.	a b c d e	<hr/>
88. The basic assumptions which underlie the curriculum program are appropriate for teachers with these prerequisites.	a b c d e	<hr/>
89. The prerequisites of teachers are appropriate for attaining the general objectives.	a b c d e	<hr/>
90. The prerequisites of teachers are appropriate for attaining the specific objectives.	a b c d e	<hr/>
91. The guidelines for specifying objectives are appropriate for the persons who will be determining the objectives.	a b c d e	<hr/>
92. The activities specified for the program are appropriate for teachers with these prerequisites.	a b c d e	<hr/>
93. The materials specified for the program are appropriate for teachers with these prerequisites.	a b c d e	<hr/>
94. The structure of the curriculum program is appropriate for teachers with these prerequisites.	a b c d e	<hr/>
95. The teaching methods stated for the program are appropriate for teachers with these prerequisites.	a b c d e	<hr/>
96. The teachers' roles stated for this program are appropriate for teachers with the prerequisites outlined by the developers.	a b c d e	<hr/>



SECTION III. ENJOYMENT OF THE CURRICULUM PROGRAM

This set of items concerns the amount of ENJOYMENT which the program will promote in the students and the teachers.:

	<u>RATING</u>					<u>COMMENTS</u>
	a	b	c	d	e	
97. Students with the required general background will enjoy the subject matter content.						_____
98. Students with the required age range and/or grade level will enjoy the subject matter content of the program.						_____
99. Students with the specific prerequisites will enjoy the subject matter of the program.						_____
100. Teachers with the necessary prerequisites will enjoy the subject matter content of the program.						_____
101. Students with the stated general background will enjoy the activities of the program.						_____
102. Students with the required age range and/or grade level will enjoy the activities of the program.						_____
103. Students with the specific prerequisites will enjoy the activities of the program.						_____
104. Teachers with the necessary prerequisites will enjoy the activities of the program.						_____

	R A T I N G					C O M M E N T S
	a	b	c	d	e	
105. Students with the required age range and/or grade level will enjoy the materials to be used in this program.	a	b	c	d	e	_____
106. Students with the specific prerequisites will enjoy the materials specified for the program.	a	b	c	d	e	_____
107. Students with the general background will enjoy the materials to be used in this program.	a	b	c	d	e	_____
108. Teachers with the necessary prerequisites will enjoy the materials specified for the program.	a	b	c	d	e	_____
109. Students with the stated age range and/or grade level will enjoy the conditions of the program.	a	b	c	d	e	_____
110. Students with the general background will enjoy learning under the specified conditions.	a	b	c	d	e	_____
111. Students with the specific prerequisites will enjoy learning under these conditions.	a	b	c	d	e	_____
112. Teachers with the necessary prerequisites will enjoy teaching under the conditions outlined for the program.	a	b	c	d	e	_____
113. The way the program is structured will stimulate the enjoyment of students with this general background.	a	b	c	d	e	_____

	<u>R A T I N G</u>					<u>C O M M E N T S</u>
	a	b	c	d	e	
114. The way the program is structured will stimulate the enjoyment of students with the specified age range and/or grade level.						_____
115. The way the program is structured will stimulate the enjoyment of students with the specific prerequisites.						_____
116. The structure of the program will stimulate the enjoyment of teachers with the appropriate prerequisites.						_____
117. Students with the required age range and/or grade level will enjoy the teaching methods intended for the program.						_____
118. Students with the required general background will enjoy the teaching methods intended for the program.						_____
119. Students with the specific prerequisites will enjoy the teaching methods intended for the program.						_____
120. Teachers with the necessary prerequisites will enjoy the teaching methods intended for the program.						_____
121. Students with the required age range and/or grade level will enjoy the roles to be performed by the teacher during this program.						_____
122. Students with the required general background will enjoy the roles to be performed by the teacher.						_____

	<u>RATING</u>					<u>COMMENTS</u>
	a	b	c	d	e	
123. Students with the specific prerequisites will enjoy the roles to be performed by the teacher in this program.						
124. Teachers with the necessary prerequisites will enjoy performing the roles suggested for the program.						
125. Students with the required age range and/or grade level will enjoy the evaluation procedures outlined for the program.						
126. Students with the specified general background will enjoy the evaluation procedures outlined for the program.						
127. Students with the specific prerequisites will enjoy the evaluation procedures suggested for the program.						
128. Teachers with the appropriate prerequisites will enjoy the evaluation procedures suggested for the program.						

#### SECTION IV : THE WORTH OF THE PROGRAM

The items in this section seek information about the WORTH of the program under study.

129. The specific subject matter of the program represents important and worthwhile content for students with the required age range and/or grade level.						
--	--	--	--	--	--	--

	<u>R A T I N G</u>	<u>C O M M E N T S</u>
	a b c d e	
130. The specific subject matter of the program represents important and worthwhile content for students with the appropriate general background.	a b c d e	_____
131. The specific subject matter of the program represents important and worthwhile content for students with the specific prerequisites.	a b c d e	_____
132. The specific subject matter of the program represents important and worthwhile content for teachers with the necessary prerequisites.	a b c d e	_____
133. The basic assumptions outlined for the program represent important and worthwhile foundations for students with the appropriate age range and/or grade level.	a b c d e	_____
134. The basic assumptions represent important and worthwhile foundations for students with the specified general background.	a b c d e	_____
135. The basic assumptions represent important and worthwhile foundations for students with the specific prerequisites.	a b c d e	_____
136. The basic assumptions represent important and worthwhile foundations for teachers with the appropriate prerequisites.	a b c d e	_____
137. The objectives of this program represent important and worthwhile outcomes for students with the required age range and/or grade level.	a b c d e	_____

	<u>RATING</u>					<u>COMMENTS</u>
	a	b	c	d	e	
138. The objectives specified for this program represent important and worthwhile outcomes for students with the stated general background.						
139. The objectives stated for this program represent important and worthwhile outcomes for students with specific prerequisites.						
140. The objectives specified for this program represent important and worthwhile outcomes for teachers with the suggested prerequisites.						
141. The activities specified for the program represent important and worthwhile endeavours for students with the age range and/or grade level.						
142. The activities specified for the program represent important and worthwhile endeavours for students with the specified general background.						
143. The activities specified for the program represent important and worthwhile endeavours for students with the appropriate prerequisites.						
144. The activities specified for the program represent important and worthwhile endeavours for teachers with the appropriate prerequisites.						

	<u>R A T I N G</u>					<u>C O M M E N T S</u>
	a	b	c	d	e	
145. The materials specified for the program represent important and worthwhile stimulus for students with the required age range and/or grade level.			a			
	a	b	c	d	e	_____
146. The materials specified for the program represent important and worthwhile stimulus for students with the required general background.						
	a	b	c	d	e	_____
147. The materials specified for the program represent important and worthwhile stimulus for students with the specific prerequisites.						
	a	b	c	d	e	_____
148. The materials specified for the program represent important and worthwhile stimulus for the teachers with appropriate prerequisites.						
	a	b	c	d	e	_____
149. The specific subject matter represents important and worthwhile content for students.						
	a	b	c	d	e	_____
150. The specific subject matter represents important and worthwhile content for teachers.						
	a	b	c	d	e	_____
151. The basic assumptions represent important and worthwhile foundations for this curriculum program.						
	a	b	c	d	e	_____
152. The objectives of this program represent important and worthwhile outcomes for students.						
	a	b	c	d	e	_____

	<u>RATING</u>					<u>COMMENTS</u>
	a	b	c	d	e	
153. The objectives of this program represent important and worthwhile outcomes for teachers.						_____
154. The activities specified for this program represent important and worthwhile endeavours for students.						_____
155. The activities specified for this program represent important and worthwhile endeavours for teachers.						_____
156. The materials specified for this program represent important and worthwhile stimulus for students.						_____
157. The materials specified for this program represent important and worthwhile stimulus for teachers.						_____

#### SECTION V : INTERNAL CONSISTENCY OF THE PROGRAM

This set of items concerns INTERNAL CONSISTENCY among the different aspects of the curriculum program under study.

158. The materials specified for the program are consistent with the guidelines for formulating objectives.						_____
159. The activities specified for the program are consistent with the guidelines for formulating objectives.						_____
160. The conditions stated for the program are consistent with the guidelines for formulating objectives.						_____



	<u>R A T I N G</u>					<u>C O M M E N T S</u>
	a	b	c	d	e	
161. The guidelines for formulating objectives are consistent with the structure of the program.						_____
162. The required age range and/or grade level are consistent with the basic assumptions which underlie the program.						_____
163. The students' general background is consistent with the basic assumptions which underlie the program.						_____
164. The specific prerequisites of students are consistent with the basic assumptions which underlie the program.						_____
165. The appropriate prerequisites for teachers are consistent with the basic assumptions which underlie the program.						_____
166. The general or global objectives specified for this program are consistent with the basic assumptions which underlie the program.						_____
167. The specific objectives of the program are consistent with the basic assumptions which underlie the program.						_____
168. The materials specified for this program are consistent with the general objectives.						_____
169. The activities included in this program are consistent with the general objectives.						_____

	<u>R A T I N G</u>					<u>C O M M E N T S</u>
	a	b	c	d	e	
170. The conditions of this program are consistent with the general objectives.						
171. The general objectives are consistent with the structure of the program.						
172. The teaching methods outlined for this program are consistent with the general objectives.						
173. The specific objectives are consistent with the general objectives.						
174. The required age range and/or grade level of students are consistent with the general objectives.						
175. The stated general background for students is consistent with the general objectives.						
176. The specific prerequisites for students are consistent with the general objectives.						
177. The prerequisites for the teachers are consistent with the general objectives.						
178. The evaluation procedures are consistent with the general objectives.						
179. The age range and/or grade level of students are consistent with the specific objectives.						
180. The required general background of students is consistent with the specific objectives of the program.						

	<u>R A T I N G</u>					<u>C O M M E N T S</u>
	a	b	c	d	e	
181. The specific prerequisites for students are consistent with the specific objectives of the program.	a	b	c	d	e	_____
182. The appropriate prerequisites for teachers are consistent with the specific objectives.	a	b	c	d	e	_____
183. The materials specified for the program are consistent with the specific objectives.	a	b	c	d	e	_____
184. The activities included in the program are consistent with the specific objectives.	a	b	c	d	e	_____
185. The conditions outlined for the program are consistent with the specific objectives.	a	b	c	d	e	_____
186. The specific objectives are consistent with the way the program is structured.	a	b	c	d	e	_____
187. The teaching methods suggested for the program are consistent with the specific objectives.	a	b	c	d	e	_____
188. The roles the teachers will perform are consistent with the specific objectives.	a	b	c	d	e	_____
189. The evaluation procedures to be adopted for the program are consistent with the specific objectives.	a	b	c	d	e	_____
190. The time requirements for the completion of the program are consistent with the basic assumptions.	a	b	c	d	e	_____
191. The time requirements allotted for the program are consistent with the basic assumptions.	a	b	c	d	e	_____
192. The time requirements allotted for the program are consistent with the attainment of the specific objectives.	a	b	c	d	e	_____

	<u>RATING</u>					<u>COMMENTS</u>
	a	b	c	d	e	
193. The time requirements allotted for the program are consistent with the quantity of materials to be used.						
194. The time requirements allotted for the program are consistent with the activities to take place.						
195. The time allotted by the developers for the program is consistent with the range of evaluation procedures.						
196. The materials are consistent with the activities to be performed.						
197. The conditions outlined for the program are consistent with the activities to be performed.						
198. The specified conditions are consistent with the materials.						
199. The teaching methods suggested for the program are consistent with the materials.						
200. The materials suggested for the program are consistent with the roles to be performed by teachers.						
201. The evaluation procedures are consistent with the materials suggested for the program.						
202. The materials specified for the program are consistent with the basic assumptions.						

	<u>R A T I N G</u>	<u>C O M M E N T S</u>
	a b c d e	
203. The activities to be performed are consistent with the basic assumptions.	a b c d e	_____
204. The structure of the program is consistent with the basic assumptions.	a b c d e	_____
205. The suggested teaching methods are consistent with the basic assumptions.	a b c d e	_____
206. The teachers' roles suggested for the program are consistent with the basic assumptions.	a b c d e	_____
207. The evaluation procedures suggested for the program are consistent with the basic assumptions.	a b c d e	_____
208. The activities specified for the program are consistent with the structure of the curriculum.	a b c d e	_____
209. The teaching methods suggested for the program are consistent with the activities to be performed.	a b c d e	_____
210. The roles to be performed by teachers are consistent with the activities of the program.	a b c d e	_____
211. The evaluation procedures to be used with the program are consistent with the activities.	a b c d e	_____
212. The suggested teaching methods are consistent with the structure of the program.	a b c d e	_____
213. The suggested roles of the teachers are consistent with the structure of the program.	a b c d e	_____

	<u>R A T I N G</u>					<u>C O M M E N T S</u>
	a	b	c	d	e	
214. The evaluation procedures are consistent with the way the program is structured.						_____
215. The evaluation procedures are consistent with the suggested teaching methods.						_____
216. The teachers' roles suggested for the program are consistent with the teaching methods.						_____
217. The basic assumptions which underlie the curriculum program are consistent throughout the program.						_____
218. The general objectives are consistent throughout the program.						_____
219. The specific objectives are consistent throughout the program.						_____
220. The evaluation procedures are consistent throughout the program.						_____

Appendix D

Guiding Questions to Aid in the Development of  
Curriculum and Instruction Units

(Anderson, 1972)

Guiding Questions for Developing Curriculum and Instruction  
Plans, and Instruction (Based on Johnson's Model)\*

- 1.0 How will you select the ILO's from the cultural content?
  - 1.01 What criteria did you use to select the ILO's?
  - 1.02 Did you obtain the ILO's you desired?
  - 1.11 What are desirable<sup>2</sup> criteria for the selection of ILO's?
  - 1.12 What are desirable ILO's?
  - 1.21 If there is a discrepancy between desirable criteria and used criteria, then how should you deal with the discrepancy?
  - 1.22 If there is a discrepancy between obtained ILO's and desirable ILO's, then how should you deal with the discrepancy?
  
- 2.0 How will you organize the ILO's?
  - 2.01 What criteria did you use to organize the ILO's?
  - 2.02 Did you obtain the organization of ILO's you desired?
  - 2.11 What are desirable criteria for the organization of ILO's?
  - 2.12 What is a desirable organization of ILO's?

---

\* The questions were designed to enable analysis as well as development in the present paper only they have been reworded and modified to meet the existing needs of Project Atlantic Canada. The writer recognizes that project team members are developing curriculum and instructional plans.

<sup>1</sup> Whenever the word criteria is used, it is assumed that an adequate rationale will be used in the selection of criteria.

<sup>2</sup> Desirable refers to local needs, as well as educational theory.



- 2.21 If there is a discrepancy between desirable criteria and used criteria, then how should you deal with the discrepancy?
- 2.22 If there is a discrepancy between obtained organization of ILO's and desirable organization of ILO's, then how should you deal with the discrepancy?

3.0 How will you establish the relationship between Instructional Content (ILO's and instrumental content) and Teaching Strategies?

- 3.01 Did you establish the relationship between Instructional Content and Teaching Strategies you desired?
- 3.02 What criteria will you use to select the instrumental content?
- 3.03 Did you establish the relationship between instrumental content and ILO's you desired?
- 3.04 Given the ILO's as goals, what teaching strategies did you provide for student transactions with the display and for teacher-student interaction?
- 3.05 What rationale was given for the teaching strategies adopted?
- 3.11 What is the desirable relationship between instructional content and teaching strategies?
- 3.12 What are desirable criteria for the selection of instrumental content?
- 3.13 What is a desirable relationship between instrumental content and ILO's.
- 3.14 What are desirable teaching strategies that will provide for student transactions with the display and for T-S interaction?
- 3.15 What is a desirable rationale for the teaching strategies adopted?

- 3.21. If there is a discrepancy between the desirable relationship between instructional content and teaching strategies and the relationship you established, how should you deal with the discrepancy?
- 3.22. If there is a discrepancy between the desirable criteria for the selection of instrumental content and the criteria you used, how should you deal with the discrepancy?
- 3.23. If there is a discrepancy between a desirable relationship between instrumental content and ILO's and the relationship you established, how should you deal with the discrepancy?
- 3.24. If there is a discrepancy between desirable teaching strategies and the teaching strategies you provided, how should you deal with the discrepancy?
- 3.25. If there is a discrepancy between a desirable rationale for the teaching strategies adopted and the rationale you gave, how should you deal with the discrepancy?
- 4.0 How will teacher Y implement the instructional plan?
- 4.01. How did Y behave in relation to student transaction with the display?
- 4.02. How did Y interact with the students?
- 4.03. Did teacher Y implement the instructional plan you desired?
- 4.11. What is a desirable way for teacher Y to behave in relation to student transaction with the display?
- 4.12. What is a desirable way for teacher Y to interact with the students?

- 4.13 What is a desirable way for teacher Y to implement the desirable instructional plan?
- 4.21 If there is a discrepancy between a desirable way for teacher Y to behave in relation to student transaction with the display and the way he did behave, how should you deal with the discrepancy?
- 4.22 If there is a discrepancy between a desirable way for teacher Y to interact with the students and the way he did interact, how should you deal with the discrepancy?
- 4.23 If there is a discrepancy between a desirable way for teacher Y to implement the desirable instructional plan and the way he did implement it, how should you deal with the discrepancy?
- 5.0 How will you view the process of evaluation of curriculum development and instructional planning?
- 5.01 How did you view the process of evaluation of curriculum development and instructional planning?
- 5.02 What is a desirable way for the process of evaluation of curriculum development and instructional planning to be viewed?
- 5.03 If there is a discrepancy between a desirable way for the process of evaluation of curriculum development and instructional planning to be viewed and the way you viewed it, how should you deal with the discrepancy?

Appendix E

Teacher Questionnaire for Lesson (TEQL)

TEACHER QUESTIONNAIRE FOR LESSON (TEQL)SUPPLEMENTARY INFORMATION

- a) The name of the unit/episode, or program is \_\_\_\_\_  
\_\_\_\_\_
- b) The lesson you are reacting to is about \_\_\_\_\_  
\_\_\_\_\_
- c) Your name \_\_\_\_\_ Sex \_\_\_\_\_
- d) The school's name is \_\_\_\_\_
- e) The age range and/or grade level of students \_\_\_\_\_  
\_\_\_\_\_
- f) Today's date is \_\_\_\_\_

The following are some statements about what happened in class during today's lesson. Circle the letter at the right side of the sheet which best represents your response to each statement and write in the space provided any comments you may wish to make.

Not at all (a)	Not much (b)	Much (c)	Very much (d)	Not applicable (e)	C O M M E N T S
----------------------	--------------------	-------------	---------------------	--------------------------	-----------------

1. I enjoyed working with the students.      a      b      c      d      e      -----

2. I enjoyed working with other teachers during the lesson.      a      b      c      d      e      -----

3. I enjoyed working with the materials.      a      b      c      d      e      -----

4. I enjoyed the activities that occurred in today's lesson.      a      b      c      d      e      -----

5. I enjoyed the location of the class.      a      b      c      d      e      -----

Not at all (a)	Not much (b)	Much (c)	Very much (d)	Not applicable (e)	C O M M E N T S
----------------------	--------------------	-------------	---------------------	--------------------------	-----------------

Not at all (a)	Not much (b)	Much (c)	Very much (d)	Not applicable (e)	C O M M E N T S
<hr/>					

6. I enjoyed the way that  
the students were grouped  
for today's lesson.

a      b      c      d      e -----

7. I understood the students  
during the lesson.

a      b      c      d      e -----

8. I understood the  
materials.

a      b      c      d      e -----

9. I understood the  
activities that  
took place.

a      b      c      d      e -----

10. I understood the  
purpose of the  
location of the  
class for today's  
activities.

a      b      c      d      e -----

11. I understood the  
purpose of the  
grouping of students  
for today's lesson.

a      b      c      d      e -----

Not at all (a)    Not much (b)    Very much (c)    Not applicable (d)    Not applicable (e)    C O M M E N T S

12. I understood the purpose of using the materials for today's activities.    a    b    c    d    e    -----
13. I encouraged the students during the lesson.    a    b    c    d    e    -----
14. The students enjoyed today's lesson.    a    b    c    d    e    -----
15. Other teachers enjoyed today's lesson.    a    b    c    d    e    -----
16. The students enjoyed their grouping for this lesson.    a    b    c    d    e    -----
17. The students enjoyed the location of the class in relation to the activities that occurred during the lesson.    a    b    c    d    e    -----
18. The students understood today's lesson.    a    b    c    d    e    -----



	Not at all (a)	Not much (b)	Much (c)	Very much (d)	Not applicable (e)	COMMENTS
19. The students understood the materials that they used during the lesson.	a	b	c	d	e	-----
20. The students understood the activities during the lesson.	a	b	c	d	e	-----
21. The students understood the purpose of their group- ing during the lesson.	a	b	c	d	e	-----
22. The students understood the purpose of the location of the class for today's lesson.	a	b	c	d	e	-----
23. The students encouraged other students.	a	b	c	d	e	-----
24. The students encouraged the teacher.	a	b	c	d	e	-----

	Not at all (a)	Not much (b)	Much (c)	Very much (d)	Not applicable (e)	COMMENTS
25. The materials were appropriate to the students.	a	b	c	d	e	----- 5
26. The materials were appropriate to your method of teaching.	a	b	c	d	e	-----
27. The activities were appropriate to the students.	a	b	c	d	e	-----
28. The location of the class was appropriate to the students for carrying on their activities.	a	b	c	d	e	-----
29. The physical arrangement for the students was appropriate.	a	b	c	d	e	-----

WHAT IMPROVEMENTS IN THE SPECIFICATION FOR TODAY'S LESSON SHOULD BE MADE ?

---



---

Appendix F

Student Questionnaire for Lesson

(STQL)

STUDENT QUESTIONNAIRE FOR LESSON (STQL)SUPPLEMENTARY INFORMATION

- a) Today's lesson is about \_\_\_\_\_  
\_\_\_\_\_
- b) Today's date is \_\_\_\_\_  
\_\_\_\_\_
- c) My name is \_\_\_\_\_
- d) I am \_\_\_\_\_ a boy \_\_\_\_\_ a girl \_\_\_\_\_
- e) My age is \_\_\_\_\_
- f) I am in grade \_\_\_\_\_
- g) My teacher's name is \_\_\_\_\_
- i) My school's name is \_\_\_\_\_  
\_\_\_\_\_

STUDENT QUESTIONNAIRE FOR LESSON (STQL)

The following are some statements about what happened in the class during today's lesson. Circle the letter at the right side of the sheet which best tells how you feel about what happened. Write in the space provided any comments you may wish to make.

First let us give you an example :

Suppose we ask you to respond to a statement about a film you viewed in the classroom today :

Not at all (a)	Not much (b)	Very much (c)	Very much (d)	Not applicable (e)	COMMENTS
----------------------	--------------------	---------------------	---------------------	--------------------------	----------

- I enjoyed watching the film during the lesson.      a      b      c      d      e

If the film did not interest you or was boring then circle the letter **a** which represents "not at all".

If you found parts of the film interesting, and you enjoyed only these parts, then circle the letter **b** which represents "not much".

Suppose you found the film interesting but not all that exciting, then circle the letter **c** which represents "much".

But if you thought the film was very interesting and very exciting, then circle the letter **d** which represents "very much".

Do not waste time puzzling over which letter to choose - circle the letter which first seems best and go on to the next.

Not at all	Not much	Very much	Very much	Not applicable	C O M M E N T S
(a)	(b)	(c)	(d)	(e)	

---

1. I enjoyed working with the other students during the lesson .      a      b      c      d      e      -----

2. I enjoyed working with the teacher during the lesson.      a      b      c      d      e      -----

3. I enjoyed working with the books, laboratory equipment or other materials.      a      b      c      d      e      -----

4. I enjoyed the activities that occurred during the lesson.      a      b      c      d      e      -----

5. I enjoyed the physical arrangement (grouping) of students for this lesson .      a      b      c      d      e      -----

Not at all (a)	Not much (b)	Very much (c)	Very much (d)	Not applicable (e)	COMMENTS
----------------------	--------------------	---------------------	---------------------	--------------------------	----------

- |   |   |   |   |   |   |       |
|---|---|---|---|---|---|-------|
| 6. I enjoyed the location of the class for today's activities.  | a | b | c | d | e | ----- |
| 7. The teacher enjoyed working with the students.   | a | b | c | d | e | ----- |
| 8. The teacher enjoyed working with the books, laboratory equipment or other materials during the lesson. | a | b | c | d | e | ----- |
| 9. The teacher enjoyed the activities that occurred during the lesson.                                    | a | b | c | d | e | ----- |
| 10. The teacher enjoyed the location of the class where the lesson was held.                              | a | b | c | d | e | ----- |

Not at all (a)	Not much (b)	Very much (c)	Very much (d)	Not applicable (e)	COMMENTS
----------------------	--------------------	---------------------	---------------------	--------------------------	----------

11. The teacher enjoyed the way the students were grouped for this lesson.

a	b	c	d	e	-----
---	---	---	---	---	-------

12. I understood other students during today's lesson.

a	b	c	d	e	-----
---	---	---	---	---	-------

13. I understood the students during today's lesson.

a	b	c	d	e	-----
---	---	---	---	---	-------

14. I understood the materials that were handled in today's lesson.

a	b	c	d	e	-----
---	---	---	---	---	-------

15. I understood the activities that occurred during the lesson.

a	b	c	d	e	-----
---	---	---	---	---	-------

16. I understood the purpose for using the materials during the lesson.

a	b	c	d	e	-----
---	---	---	---	---	-------



Not at all (a)    Not much (b)    Very much (c)    Not applicable (d)    Not applicable (e)    COMMENTS

---

17. I understood the purpose of the activities that took place during the lesson.    a    b    c    d    e    -----
18. I understood the purpose for the class grouping during this lesson.    a    b    c    d    e    -----
19. I understood the purpose for the location of the class for today's lesson.    a    b    c    d    e    -----
20. The teacher understood the students during today's lesson.    a    b    c    d    e    -----
21. The teacher understood the materials.    a    b    c    d    e    -----
22. The teacher understood the activities that took place during the lesson.    a    b    c    d    e    -----

	Not at all	Not much	Very much	Not applicable	C O M M E N T S
	(a)	(b)	(c)	(d)	(e)

23. The teacher understood  
the purpose for the  
location of the class

a	b	c	d	e	-----
---	---	---	---	---	-------

24. The teacher understood  
the purpose for the way  
the students were  
grouped.

a	b	c	d	e	-----
---	---	---	---	---	-------

25. The teacher understood  
the purpose of the  
materials for today's  
lesson.

a	b	c	d	e	-----
---	---	---	---	---	-------

26. I encouraged the  
teacher during the  
lesson

a	b	c	d	e	-----
---	---	---	---	---	-------

27. I encouraged other  
students during the  
lesson.

a	b	c	d	e	-----
---	---	---	---	---	-------

28. The teacher encouraged  
the students during the  
lesson.

a	b	c	d	e	-----
---	---	---	---	---	-------

	Not at all (a)	Not much (b)	Very much (c)	Very much (d)	Not applicable (e)	COMMENTS
--	----------------------	--------------------	---------------------	---------------------	--------------------------	----------

- |   |   |   |   |   |   |       |
|---|---|---|---|---|---|-------|
| 29. Other students encouraged the teacher.            | a | b | c | d | e | ----- |
| 30. The materials were appropriate to me.             | a | b | c | d | e | ----- |
| 31. The activities were appropriate to me.            | a | b | c | d | e | ----- |
| 32. The materials were appropriate to the teacher.    | a | b | c | d | e | ----- |
| 33. The materials were appropriate to other students. | a | b | c | d | e | ----- |
| 34. The activities were appropriate to the teacher.   | a | b | c | d | e | ----- |

Not at all	Not much	Very much	Not applicable	C O M M E N T S
(a)	(b)	(c)	(d)	(e)

---

35. The activities were appropriate to other students.      a      b      c      d      e      -----

36. The class grouping was appropriate to me.      a      b      c      d      e      -----

37. The location of the class was appropriate to me.      a      b      c      d      e      -----

38. The students grouping was appropriate to the teacher.      a      b      c      d      e      -----

39. The students grouping was appropriate to other students.      a      b      c      d      e      -----

40. The location of the class was relevant to the teacher's method of teaching.      a      b      c      d      e      -----

Not at all (a)	Not much (b)	Very much (c)	Very much (d)	Not applicable (e)	COMMENTS
----------------------	--------------------	---------------------	---------------------	--------------------------	----------

---

41. The location of the  
class was relevant to  
the other students.

a      b      c      d      e

-----

WHAT IMPROVEMENTS WOULD YOU SUGGEST IN TODAY'S LESSON?

-----  
-----  
-----

Appendix G

Tables and Graphs of Results of  
Student Questionnaire

TABLE 1

STQL Miscouche Regional High, P.E.I.

Question Numbers	Responses			Percentage		
	Positive	Negative	Total	Positive	Negative	Total
1, 2	148	46	194	76	24	100
3, 4	131	63	194	68	32	100
6	82	15	97	85	15	100
14, 15	113	35	148	76	24	100
16, 19	131	27	148	89	11	100
26, 27	39	109	148	26	74	100
30, 31	167	27	194	86	14	100
33	53	16	69	77	23	100

NOTE: No table or graph is presented for STQL at A. G. Hisock Academy, Corner Brook, Newfoundland since only one questionnaire with a consensus of student opinion was returned to the writer.

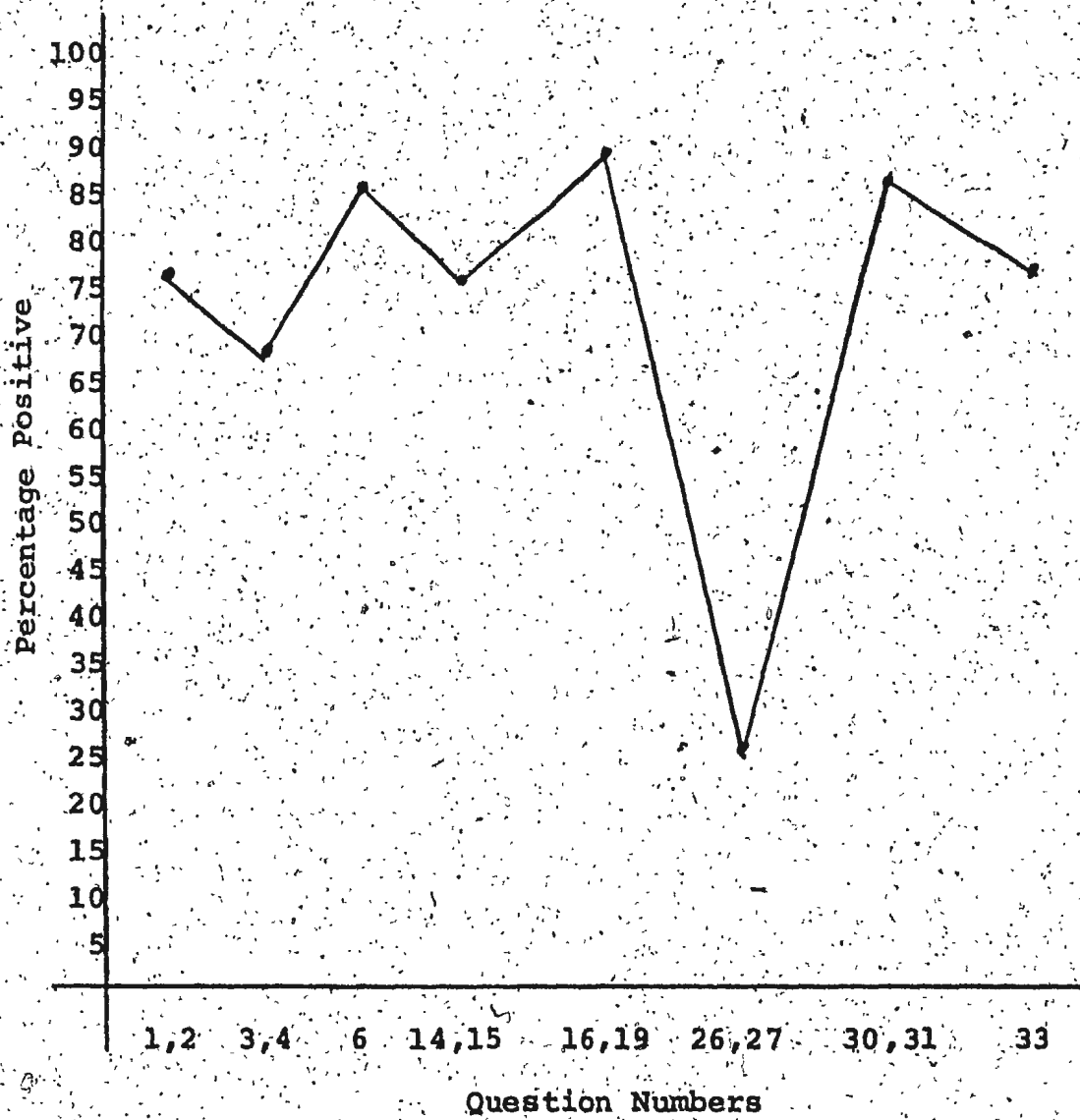

Fig. 3. STQL Miscouche Regional High, Prince Edward Island

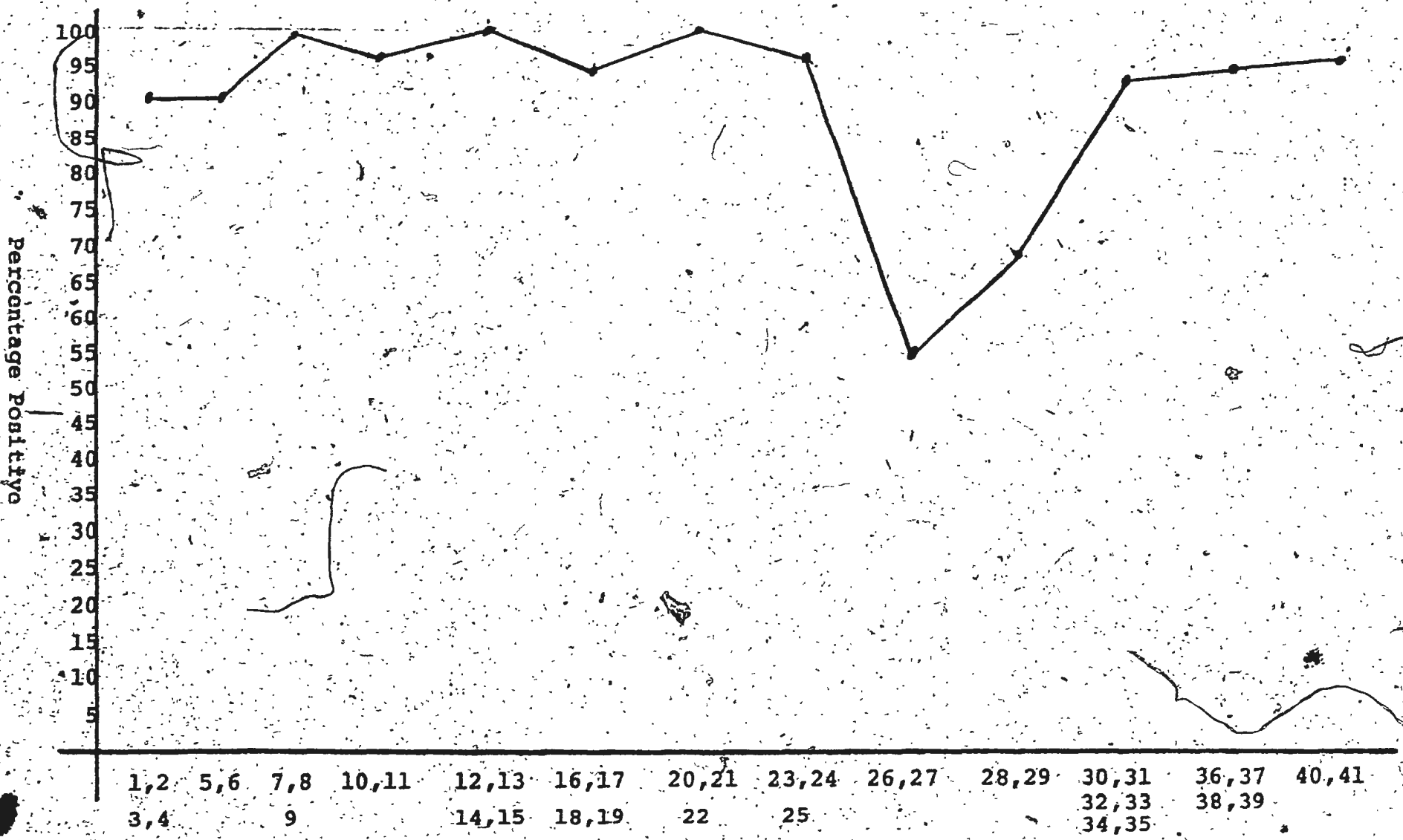

TABLE 2

STQL Vineland Public School, Ontario

Question Numbers	Responses to Both Administrations			Percentage		
	Positive	Negative	Total	Positive	Negative	Total
1, 2, 3, 4	203	21	224	91	9	100
5, 6	102	10	112	91	9	100
7, 8, 9	166	2	168	99	1	100
10, 11	108	4	112	96	4	100
12, 13, 14, 15	221	3	224	99	1	100
16, 17, 18, 19	210	14	224	94	6	100
20, 21, 22	166	2	168	99	1	100
23, 24, 25	161	7	168	96	4	100
26, 27	62	50	112	55	45	100
28, 29	77	69	112	69	31	100
30, 31, 32, 33 34, 35	312	24	336	93	7	100
36, 37, 38, 39	211	13	224	94	6	100
40, 41	106	6	112	95	5	100

Fig. 4. STPL Vineland Public School, Ontario



Question Numbers

175

Percentage Positive

**END**

**FIN**

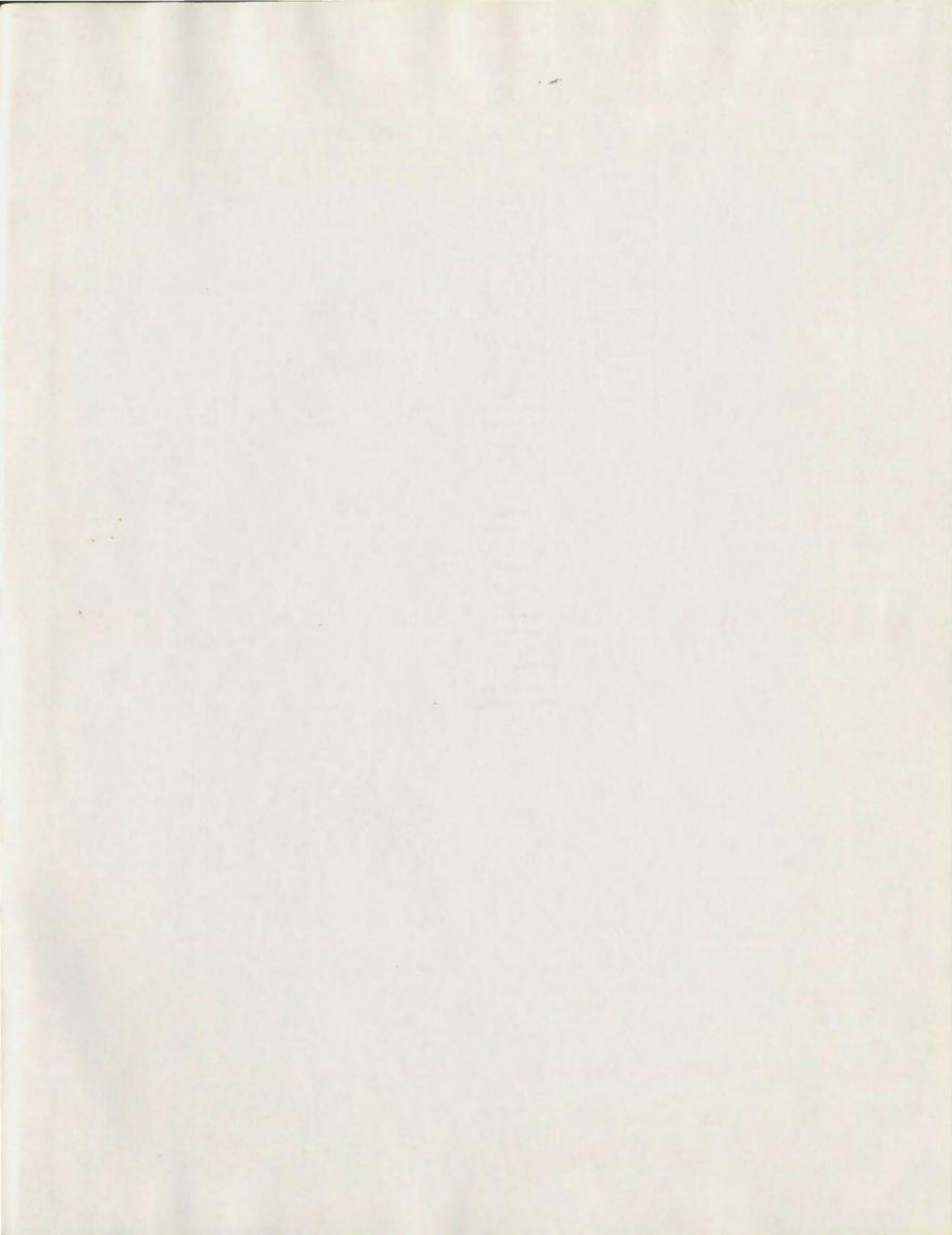

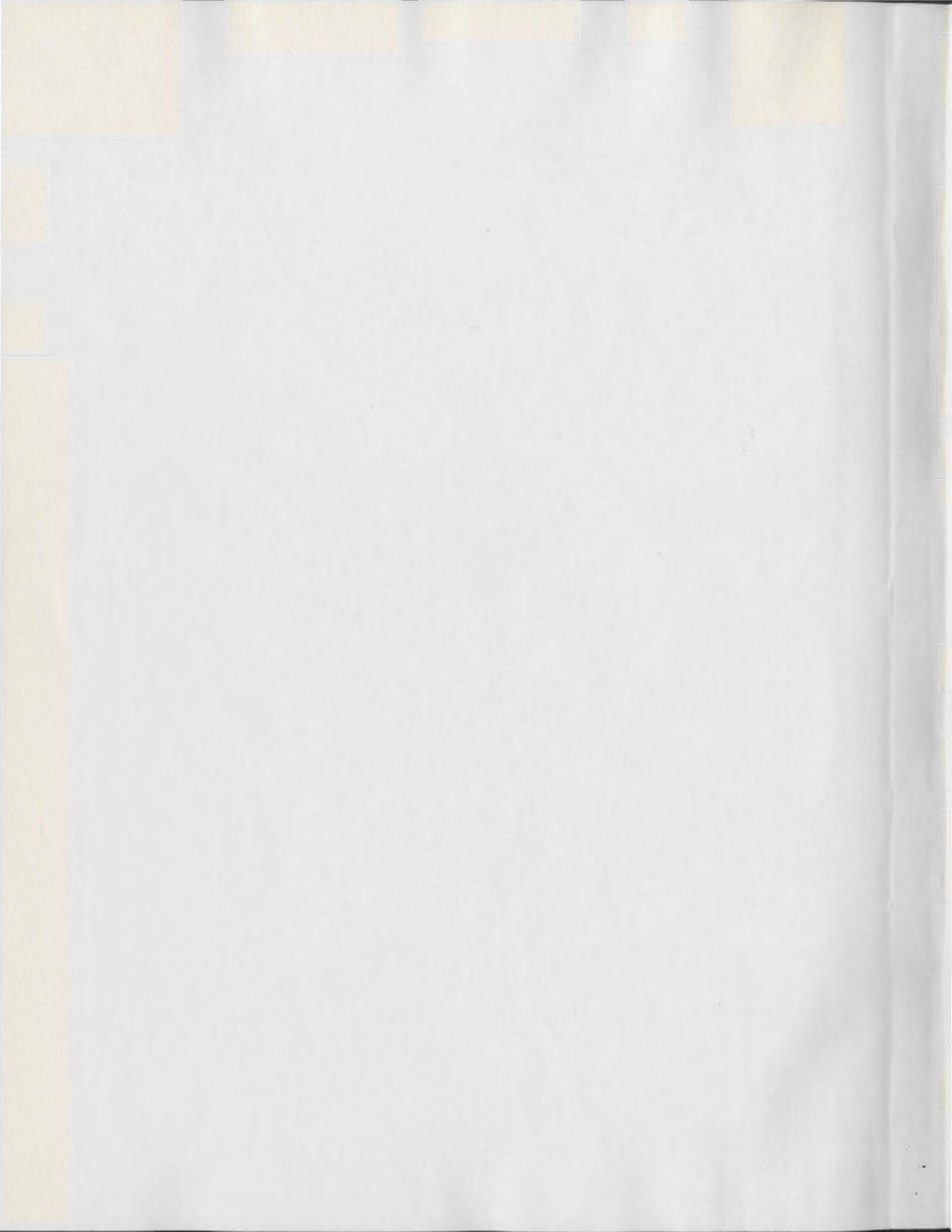

COMMUNITY  
TECHNOLOGISTS

