

A REPORT ON THE DEVELOPMENT OF A PROGRAM
ENTITLED TECHNOLOGY EDUCATION:
WITH SPECIFIC APPLICATIONS IN
INDUSTRIAL TECHNOLOGY

CENTRE FOR NEWFOUNDLAND STUDIES

**TOTAL OF 10 PAGES ONLY
MAY BE XEROXED**

(Without Author's Permission)

LEON COOPER



A REPORT ON THE DEVELOPMENT OF A PROGRAM

Entitled

**TECHNOLOGY EDUCATION:
WITH SPECIFIC APPLICATIONS IN INDUSTRIAL TECHNOLOGY.**

BY

© Leon Cooper, B.Sc., B.Voc.Ed.

**Submitted to the School of Graduate
Studies in partial fulfillment of the
requirements for the degree of**

Master of Education

**Faculty of Education
Division of Learning Resources
July 1988**

St John's

Newfoundland

Permission has been granted to the National Library of Canada to microfilm this thesis and to lend or sell copies of the film.

The author (copyright owner) has reserved other publication rights, and neither the thesis nor extensive extracts from it may be printed or otherwise reproduced without his/her written permission.

L'autorisation a été accordée à la Bibliothèque nationale du Canada de microfilmer cette thèse et de prêter ou de vendre des exemplaires du film.

L'auteur (titulaire du droit d'auteur) se réserve les autres droits de publication; ni la thèse ni de longs extraits de celle-ci ne doivent être imprimés ou autrement reproduits sans son autorisation écrite.

ISBN 0-315-45098-3

Abstract

This project was undertaken to develop a 30 hour introductory course of study in technology education for third year Diploma of Industrial Arts students at Memorial University of Newfoundland.

A review was conducted of the development of industrial arts programs in North America, the growing influence of technology on society and education, and the development of technology education programs. A brief review was conducted of world wide trends in technology education and of a number of programs in North America.

A technology education program was developed and evaluated using the Thiagaragan 4-D instructional development process of Define, Design, Develop, and Disseminate. The program consisted of a three hour introduction to technological systems (An Overview of Technology), followed by 27 hours of Technology Learning Activities (TLAs) in selected technologies. There were two computer assisted drafting TLAs, three robotics TLAs, and two desktop publishing TLAs.

The course was successfully tested and was adopted by the university as a component of the Industrial Education program.

Acknowledgements

I would like to acknowledge the assistance and encouragement of my thesis advisor Dr. G. Fizzard.

I would also like to thank the Director of the Division of Special Programs for providing me with a forum for developing this program, and his staff for their assistance at very inopportune times.

Last, but not least, I would like to thank my wife, Judy for her encouragement and help.

Table of Contents

DESIGN	1
Chapter 1, The Project	1
Introduction	1
The Newfoundland industrial education program	1
Technology's effects on industry and industrial education	2
Definition of Terms	4
Problem Statement	6
Proposed Solution to the Problem	8
Instruction Development Process	9
Chapter 2, Review of the Literature	11
Evolution of Industrial Arts Technology	13
Technology and Science	19
Technology and Society	20
Technology and Society	21
Technology Education	26
Purpose of Technology Education	31
The Development of Technology Curriculum Models	39

Developing Technology Programs	48
Standards for Implementing Technology Programs	61
Implementation Strategies	62
International Curriculum Projects	64
The North American Programs	67
John Hanson Middle School	67
Grace Atlanta High School	70
New York State High School Program	74
Triad High School	75
Newport News Public Schools	80
Pittsburg Middle School	82
Chicago Public Schools	83
Wood River Industrial Technology Program	85
The New Brunswick Program	94
Summary	109
Chapter 3, Front End Analysis	112
Learner Analysis	112
Concept/Task Analysis	115
Instructional Objectives	140
DESIGN	150

Chapter 4, Designing the Course	150
Criterion Referenced Testing	150
Media Selection	151
Media Selection Decisions	152
DEVELOP	154
Chapter 5, Developing the Course	154
The Search for Existing Materials	154
Initial Development of Materials	157
Formative Evaluation - Expert		
Appraisals	161
The Experts	162
Expert Appraisals	163
Formative Evaluation - Developmental		
Testing	167
DISSEMINATION	171
Chapter 5, Summative Evaluation	171
Validation Testing	171
Chapter 6, Results, Implications,		
and Recommendations	187
Results	187
Implications	187
Recommendations	188
References	189
Appendix A	197

Appendix B	200
Appendix C	206
Appendix D	213
Appendix E	215

List of Tables

Table 1 Pre/Post Test Scores for Introduction to Technology 176
Table 2 Computer Assisted Drafting Results 179
Table 3 Robotics Results 181
Table 4 Desktop Publishing Results 184

List of Figures

Figure 1 The Outcomes of Technology	24
Figure 2 Levels of Technology in a Society	29
Figure 3 Mutual Interaction Model	36
Figure 4 Universal Systems Model	42
Figure 5 Human Technical Endeavours Subsystems	44
Figure 6 ITEA Curriculum Model	47
Figure 7 Content Model for Technology Education	50
Figure 8 ITEA Middle School Content Model	54
Figure 9 ITEA High School Content Model	56
Figure 10 Model of Technology Education Content based on Swyt's Schema	60
Figure 11 TTEC Course Structure	78
Figure 12 Wood River Technology Program	87
Figure 13 Wood River Manufacturing		

Technology Course	89
Figure 14 Wood River Industrial Processes Course	91
Figure 15 Wood River Principles of Technology Course	96
Figure 16 New Brunswick Information Projects	99
Figure 17 New Brunswick Activity Projects	101
Concept Analyses Diagrams:		
Concept Analysis for An Overview of Technology	118
Concept Analysis for Computer Assisted Drafting	120
Concept Analysis for Robotics	122
Concept Analysis for Desktop Publishing	124
Task Analyses Diagrams:		
Task Analysis for CAD TLA 1	127
Task Analysis for CAD TLA 2	129
Task Analysis for Robotics TLA 1	131

Task Analysis for Robotics TLA 2	133
Task Analysis for Robotics TLA 3	135
Task Analysis for Desktop Publishing TLA 1	137
Task Analysis for Desktop Publishing TLA 2	139

List of Abbreviations

Computer Assisted Drafting	CAD
Computer Integrated Manufacturing	CIM
Desktop Publishing	DTP
Technology Learning Activity	TLA
Criterion Referenced Test	CRT
International Technology Education Association	ITEA

DEFINE

Chapter 1

The ProjectIntroduction

Industrial Education is a continuously evolving secondary school program. Its most recent primary function has been to interpret industry, its occupations, processes, products and structures. In practical terms, programs have been oriented towards traditional industrial practices in (1) materials and processes, (2) industrial communications, and (3) power and energy. Examples of responses to these interpretations have been the traditional course offerings in house construction, woods, metals, and plastics; blueprint reading, and drawing and planning; and power mechanics.

The Newfoundland industrial education program.

Industrial education in the Province of Newfoundland is a relatively recent phenomena. Although it existed at the junior high-level and in a few urban high schools for a number of years, and as pre-

vocational programs at 12 selected centers before the reorganized high school program was implemented in 1982, it was with the new high school program that industrial education was established in most school districts across the province.

The Newfoundland program follows the traditional model of industrial education. Course offerings at the high school level include building construction, woods and metals, drawing and planning, electricity, electronics, and power mechanics. Additional courses are offered in marine industries and home maintenance.

Many industrial education teachers in this province have received specialized training from Memorial University through the Diploma of Industrial Arts program. This three-summer, ten-credit program provides teachers with practical experiences in each of the courses offered in the public schools.

Technology's effects on industry and industrial education.

All aspects of daily life in western society and in particular in the world of industry are dominated by advanced technology. Industrial practices are greatly affected by technological developments. The rate of

technological change and development in industry is very quickly broadening the gap between industrial practice and the teachings of industrial education in the public schools.

Industrial education, with its traditional program, can no longer emulate modern industry. Over the past couple of decades this has created enormous pressures for change. The result of this pressure is the evolution of a new type of program - technology education. Where industrial education was based on technical means (the processes required for use of specific tools and materials), technology education is based on technological processes. Technology education is concerned with technology; the effects of technology on industry, society and the person are the major focus of study. In addition, advanced technological processes are employed in the study of technology.

The transition from traditional industrial education to technology education is not without its problems. The large investment in laboratories, equipment, and personnel training contribute to a resistance to change. Restructuring and redesigning programs is time consuming and expensive. One of the most difficult problems for the delivery of new programs

is the retraining of teachers.

Retraining teachers in the field is beyond the scope of this project. The project's focus is to develop a method of providing introductory technology education to a select audience, the third year Diploma of Industrial Arts students at Memorial University.

Definition of Terms.

For this project the main terms are defined below. Others are defined as they are introduced.

Industrial Arts is the school subject specifically concerned with providing knowledge and understanding of industry, its techniques, materials, human elements, and with jobs and careers pertaining (Marshall, 1975).

Technology is (1) the application of science and mathematics for specific purposes, (2) the application of knowledge, tools, and skills to solve practical problems and extend human capabilities (The Technology Teacher, 1985), and (3) comes from 'technes' or principle or method used to make something and 'logos' or the study of the principle or method used (Lauda and McCrory, 1986, and Kasprzyk, 1980).

Advanced Technology is technology which incorporates the most recent and most advanced

developments for that given technological area (Goetsch, 1988, p. 30)

Technology Education is a comprehensive, action-based educational program concerned with technical means, their evolution, utilization and significance; with industry, its organization, personnel, systems, techniques, resources and products, and their social and cultural impact (Technology education: A direction for the profession, 1985).

Technological Literacy is an understanding of technology and its dynamics, the opportunities that it offers, its impact on products and processes, markets, organizational structures and people (Jones, 1985).

Industrial Education is a generic term used to identify the component of the high school curriculum specifically concerned with an interpretation of industry, its occupations, processes, products and structures (Andrews, 1987, p. 4).

General Education is that which is believed to be the standard required learning for all students leading to the best possible preparation for personal growth and satisfaction, and for worthy contributions to society (Marshall 1975, p. 8).

Secondary School is any school which delivers

junior high and/or senior high programs.

Problem Statement.

A number of agencies in Newfoundland and Labrador have recognized the need for change in the existing industrial education program and have begun to develop strategies for implementing change.

The Industrial Education Special Interest Council (IESIC), during the Annual General Meeting (AGM) at its 1986 conference, voted on 18 resolutions relating to concerns of industrial education teachers with respect to technology education. One of these resolutions resulted in the 1987 IESIC conference on technology education. Resolutions from the 1987 AGM directed the council to pursue the development of a provincial policy on technology education using a two tier approach. First, develop a general technology course, and second, where feasible modify current courses to incorporate relevant newer technologies. The Newfoundland Provincial Industrial Arts Working Group, founded in 1984 to monitor developments in industrial arts curriculum projects, and headed by provincial Industrial Arts Coordinator Scott Marshall, has the development of just such a project as one of its current activities.

Memorial University introduced a unit of study in technology education into its Diploma program during the summer session of 1987. The program had three goals:

1. To introduce the students to concepts of Technology Education.
2. To introduce the student to computer applications appropriate to secondary level Technology Education.
3. To make students more aware of contemporary Industrial Technology Developments.

The program had clearly stated objectives (Appendix A), but had no clearly defined means of delivering those objectives. Although some courses and instructional materials were developed, they did not completely meet the needs of the program.

The Director of Special Programs at Memorial University, has expressed interest in further development of this technology unit. A series of meetings and informal discussions with the Director over the past year have laid the framework for this project, and resulted in a developer/client relationship being entered into with the Director as a representative of his department. The primary purpose of this project was to develop a four day 'Introduction to Technology'

8

module for the Industrial Arts Diploma program at Memorial University.

Proposed Solution to the Problem

Research into the evolution of industrial education in other jurisdictions with respect to the incorporation of advanced technologies provided a perspective for dealing with the development of a program to meet the university's needs. These needs, as expressed by the Director of Special Programs, were for a four day technology education course. This course introduced the student teachers in industrial education to principles of technological systems, and incorporated technology learning activities (TLAs) for a number of advanced technologies.

The course was based on current educational and industrial practices. After successful testing, the TLAs were used as a component of the industrial education program, and will serve as a guide for development of other TLAs.

For this project TLAs were developed in the following technologies: (i) Information Communications Systems - Computer Assisted Drafting, and Desktop Publishing; and (ii) Physical Systems - Robotics.

2

Emphasis was placed on the integration of these technologies into a general technological schema.

Instructional Development Process

The development of TLAs followed the 4-D model of Thiagaragan: (1) Define instructional requirements, (2) Design prototypical instructional materials, (3) Develop tested and reliable instructional materials, and (4) Disseminate the instructional materials to the educational programs (Thiagaragan, 1974).

The "Define" stage is characterized by a study of the basic problem with a view to determining alternatives to instruction or failing that, determining whether or not instructional materials exist to meet the needs. If suitable materials do not exist, materials are developed. In the latter case, a learner analysis, a task analysis, and a concept analysis are used as a base for specifying instructional objectives.

The "Design" stage involves specification of criterion-referenced test items based on the objectives. Appropriate media and format are employed to develop the initial materials design.

The "Develop" stage is used to perform formative evaluation using expert appraisals and developmental

testing.

The "Dessimination" stage commences with validation testing of the materials under replicable conditions. Final stages of this step are packaging, diffusion, and adoption.

Chapter 2

Review of the Literature

During the first stage of the development process the "Define" stage - the history of industrial arts programs was examined very briefly. The growth of technology education programs was examined and a number of technology education programs were reviewed. This chapter presents that background information.

Industrial arts developed as a discipline with a unique body of knowledge, procedures, and practitioners who held a particular world view or gestalt. Most industrial arts educators shared common theories, models of operation, and instructional content and practice. This paradigm, while continuously evolving, remained essentially the same until the mid to late sixties (Kuhn, 1970). At that time, anomalies were occurring which represented major problems for the industrial arts paradigm.

The major anomalies centered around the difference between the content and teaching of industrial arts, and the use of computerized equipment in the workplace. Industrial arts no longer reflected the industrial

practice. Industry no longer needed workers with manual skills but needed workers who could analyze situations and work with numerically controlled and computer controlled machines (Sharon, Harstein, and Fischer, 1987). Around that time, a new paradigm began to emerge. This paradigm was later to become technology education. At the time of this writing, more than two decades later, the technology education paradigm has become dominant.

According to Kuhn (1970), evidence for this dominance comes from the literature and from textbooks. All major industrial arts journals have become technology education journals in name and/or in fact. Textbooks have become technology education textbooks. Other examples of change are: A change in the name of the professional organization from the American Industrial Arts Association to the International Technology Education Association; a change in direction and in instructional content; a change in curriculum guides; a change in graduation requirements with respect to technology; and a change in position within the field to become more aligned with science and mathematics, to address technological literacy, and to spearhead federal legislation (Balistreri, 1987).

As a paradigm, technology education has not been completely resolved. Theories and models, while all based on the Jackson's Mill Curriculum Theory, remain in several competing forms. For further reference to Jackson's Mill see page 17.

Evolution of Industrial Arts

The branch of general education generally known as Industrial Arts has a long and varied history in North America. At various times, it has been called manual arts, manual training, tool instruction, shop work, sloyd, industrial education, practical arts, and industrial arts (Smith, 1981). These early programs evolved into today's mixed bag of offerings (Sanders, 1985).

Manual training was initiated in North America in the late 1800's by Calvin Woodward (Nelson, 1981). It was based on principles established in Europe by Pestalozzi in the late 1700's, and enhanced in the 1870's by Otto Salomon. Pestalozzi's child centered approach to education used objects from the natural and man made environments as part of instruction. Salomon developed the Scandinavian sloyd (woodwork) system (Nelson, 1981). The sloyd system was based on the

premise that children learn by doing, or by manipulating the actual materials. The objective of the American 1870's manual training method was to provide skills to children of working class people (Ristow, 1987). Although Woodward claimed manual training was general education, it was not widely accepted as such, and it did not last long (Smith, 1961).

American sloyd, an adaptation of Scandinavian sloyd, but using local models and ideas, was introduced in Boston in 1888 by Larsson about the same time that manual training was introduced. American Sloyd included mechanical drawing.

Manual arts was founded by Charles Bennett in the 1880's. Although not originally a specific system of instruction, it became a revised form of manual training and was expanded to include drawing, design, wood, and metal. He promoted the aesthetic as well as the practical side of manual arts.

Programs such as Runkles' 1886 'School of Mechanic Arts', Bennett's 'manual arts' movement, Dewey's 'industrial occupations', and Richards' 'industrial arts' were all adaptations of industrial education to general education during the turn of the century (Bennett, 1937).

"Industrial Arts", coined in 1904 by Charles Richards (Ristow, 1987 and Smith, 1981), had become the dominant title by 1939 when the American Industrial Arts Association was formed (Sanders, 1985). By this time, the emphasis had changed from the disciplinary value of work to a study of the elements of industry.

By the mid 1960's, however, industrial arts objectives had become blurred and its identity was confused. Some educators wanted industrial arts to include all technology, others wanted to include only industrial technology (Lux, 1981). One effect of this confusion was that students with academic problems were placed in the "shop", creating a legacy which haunts industrial educators during the current 'back to basics' movement (Ristow, 1987). Misconceptions of industrial arts are commonly held even today, due to the long time lack of clearly defined goals for industrial arts. Some of these misconceptions are: "make something to take home"; "personal likes"; "pre-vocational"; and "we represent industry in the schools" (Frye, 1987).

Although not immediately obvious, the change to technology education from manual arts or crafts actually began after World War II. The rapid change in technology that began at that time created pressures on

the discipline to change its methods. This resulted in a number of curriculum projects in the 1960's. One of these was the Industrial Arts Curriculum Project (IACP) developed in Ohio. It was the first such project based on an analysis of the structure of knowledge. It included courses and instructional materials based on a taxonomy of industrial knowledge, concepts and practices (Lux, 1979, and Lux, 1981). Other major programs developed during this time were the American Industries Project at the University of Wisconsin, the Maryland Plan, and the Alberta Plan.

There was also growing awareness of the link between science and technology and the need for industrial arts programs to be contemporary with respect to incorporating major characteristics of industrial technologies. The concept of change as the only certainty in human experience had come of age (Erber, 1969).

During this same general time period, a new phenomenon was developing at American Colleges. Industrial Technology programs were being developed. These programs would later increase the problems for traditional industrial arts teacher training programs. Industrial technology programs in colleges were in

response to the new industrial gap between the roles of engineers and those of technicians. These 'industrial technology' programs (creating technologists and middle managers, not teachers) did not immediately create problems of conflict with traditional industrial arts education programs since they were very similar in content. Also, both traditional industrial arts and industrial technology programs had high enrollments. This situation did not remain stable, and by the late seventies industrial technology programs were sufficiently different from traditional programs, and their enrollment was high enough to cause problems for traditional industrial education programs. One of the effects of those problems was declining enrollment in traditional industrial arts teacher training programs (Rudisill, 1987).

It was to resolve these, and other, problems that a number of leaders in the field met at Jackson's Mill during the period 1978-80 to forge a new direction for industrial education.

The group concluded that:

1. Industrial arts is a comprehensive educational program concerned with technology, its evolution, utilization, and significance;

with industry, its organization, personnel systems, techniques, resources, and products; and their social/cultural impact;

2. Technology is the knowledge and study of human endeavours in creating tools, techniques, resources and systems to manage man made and natural environments to extend the human potential and the relationship of these to individuals, society, and the civilization process;
3. Industry is that section of the societal economic institution that utilizes resources to produce goods, services, and information to meet the needs and wants of individuals and society (Hales and Snyder, 1986, pp 1-2).

(This attempt to bridge the gap between the many emergent programs has resulted in links being forged between the two formerly opposed camps of industrial education and technology education. It also served to shift the emphasis to technology education which Sterry (1987, p 11) suggests is a "discipline based on concepts of technology". He further states that industrial arts and trade and industrial education are

subsets of that discipline.

Technology

Technology can be simply defined as the use of knowledge to turn resources into the goods and services that people need. Technology has been a factor in human existence since a cave man wielded the first bone tool. Technology is also the sum of human knowledge, is making things work better, is the means by which people control or modify their environment, is the practical application of theory, and is a disciplined process that uses scientific, material, and human resources to achieve human purposes (Hacker and Barden, 1988, and Harrison, 1980).

Technology exists at many levels. Light, for example, can be created by using a candle, a carbon arc, or by using a variety of chemical and/or electrical processes. With a foundation in theoretical knowledge, technology is now based more on "intellectual and analytical processes than on mechanical, manipulative and physical concepts." (DeVore, 1987, p. 34). DeVore also states that the discipline of technology is "the systematic study of the creation, utilization, and behavior of adaptive systems. It includes the tools,

machines, materials, techniques, and technical means along with the behavior of those elements and systems in relation to human beings, society and the environment." (DeVore, 1987, p. 43). As an intellectual discipline, technology first addresses significant questions and then it answers them (Lauda and McCrory, 1986).

Technology and Science

Although the distinction between technology and science is often confused, they are quite different from each other (Lauda and McCrory, 1986). Both have different knowledge structures, and the basic methodology of technology is different from that of science. Although science can lead to new technology, this does not always happen. Often technology develops before science can understand the principles at work (DeVore, 1987). One such technology was the steam engine. It was developed before the science of thermodynamics was discovered. The science was later applied to improve the technology of the steam engine.

The goals of technology are to create the human capacity to do, and to create new and useful products, devices, machines or systems. The goal of science is to obtain fundamental understanding of nature and the

physical universe. Technology deals with complex, interrelated problems involving design, materials, energy, information, and control, with many variables both technical and social. Science problems are generally small, highly detailed, manageable, and are designed to contribute to a body of information as a base for generalizable theories. Technology is generally conducted directly in the social milieu, while science is generally conducted in isolation from direct social needs.

Barnes (1988) states that the following are differences between science and technology: (1) Technology is an open system; science is a closed system; (2) technology uses deductive reasoning; science uses analytical reasoning; (3) technology uses the design method; science uses the scientific method; and (4) technology is concerned with how things ought to be; science is concerned with how things are.

Technology and Society

Technology plays a major role in the value system of a society. Lauda and McCrory (1986) feel that technology is the major determinant of culture. Technical means of satisfying needs and wants are

determined by the level of technology, which in turn affects the value system. Work, leisure activities, and lifestyles are influenced by the available technology and in turn influence the value system (Glines, 1986 and 1988, and Locatis, 1988).

Some of the impacts of technology are often anticipated but others are not. Industrial use of robots, for example, has tripled in the last decade (Dunsmore and Dixon, 1987). Estimates put the number around 10,000 for American plants in 1986 (Richards, 1987). While some of the productivity impacts have been planned for, it is fair to say that not all of the social consequences of job loss and job retraining have been dealt with. Of the four possible classes of outputs from technology (expected and desirable, expected and undesirable, unexpected and desirable, and unexpected and undesirable), the latter is of most concern (Figure 1). The goal should be to match technology to the individual and to the environment (Hacker and Barden, 1988).

Waetjen (1985) gives a number of reasons why modern technology directly changes the values of society. First, the rate of change of technology is such that every job in every field, from office work to

Figure 1 The Outcomes of Technology

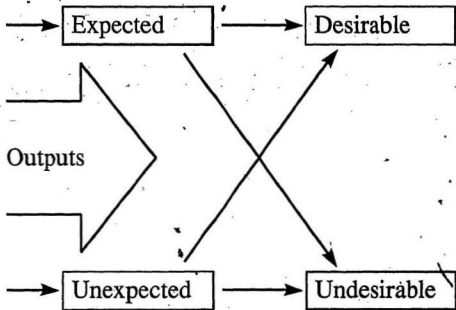

Figure 1 Multiple Technological Outputs

agriculture, is affected to the degree that highly trained workers are needed. Second, the response time for bank transactions, diplomatic communications, adversarial relationships, and, in fact, any communications has been effectively reduced to zero.

Third, the rate and method of implementation of technological developments often leads to the conclusion that technology should be pursued at all costs. The net effect on society is a change in cultural values by virtue of the rate at which choices for a given situation change.

The fourth consideration for a technological society is the separation of the worker from other workers. The contact needed for personal communication does not exist since the worker can more easily work from home using telecommunications. This tends to destroy the social fabric.

As society changed from a mainly agrarian to an industrial to an information orientation, the level of education evolved to the point that an individual needs to spend the first quarter of his life in formal education, and the rest of his life in continuing education if he wishes to function in society and in the workplace. Today's educational system cannot afford to

produce people who are technologically illiterate in a technological world (Lauda and McCrory, 1986).

Technology Education

The first attempt to integrate technology education into industrial education was the Warner proposal of 1946-7 titled A Curriculum to Reflect Technology (Phillips, 1985). This project introduced the five areas of a technology based curriculum: communications, construction, power, transportation, and manufacturing. These areas served as the basis for most of the programs developed since then.

The term 'technology education' was coined in 1970 at West Virginia University by a group of graduate and post-graduate students in response to a question concerning the title of a program that should help students "comprehend their technological inheritance and technological future." (Lauda and McCrory, p. 17, 1986).

Technology education was formally defined in 1985 by the ITEA monograph Technology Education: A Perspective on Implementation (refer to Definition of Terms, Ch. 1, page 5). There have been components of technology education in industrial arts since its beginning. The technological education component of

industrial education was mainly limited to technical means (Waetjen, 1985) and to technologies of industry, sometimes included the organization, personnel, systems, resources or products of industry, and seldom included the social/cultural impacts. For industrial arts, technical progress was secondary (Lauda and McCrory, 1986)

Modern technology is "explosive, unpredictable, remarkably beneficent, and laden with technical and social problems" (Johnson, 1985, p. 12). Johnson further defines a holistic role for education to acquaint all members of society with technology's theoretical and hands on techniques, and with the present and future social and political consequences of technology.

Boyer (1985) perceived the rapid rate of change of society - the changes in industry, in communications, in transportation, and in construction - as one of the major issues facing technology education. Present education separates academics from vocational purists - a schism that began with the ancient Greeks (Phillips, 1985). The message to the student has been 'those who pursue academics are thinkers and those who pursue anything else are workers. In fact all education is for

Figure 2 Levels of Technology in a Society

Levels of Development

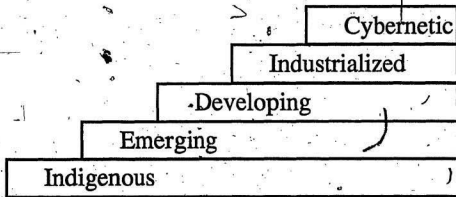

Figure 2 Levels of Technology in a Society

a vocation, and all education exposes students to great writing and great thinking. The reality is that all people are both workers and thinkers. Boyer cited the goal of technology education to be quality education.

Todd (1985) views the impact of technology education on a society as a factor of the level of technology of the society (Figure 2). The indigenous level has little educational impact, since it is the lowest level of technology (traditional) and is long term, local, and survival oriented.

The second, or emerging level, involves the transfer of technologies from other cultures and consequent educational problems of preparing people to judge the suitability of innovations. Consequences are usually considered after the fact.

The third, or developing, level provides more demands on the educational system. Technological innovations need to be questioned for appropriateness and future impacts. Technology education must provide for such 'futures planning'. This involves problem solving using a large technological database.

The fourth, industrialized, level is concerned with mastery of technical systems to mass produce and distribute hard goods. Problem solving becomes more and

more complex. As society accepts the intrinsic value of technology, the role of technology education becomes more important and complex.

The fifth and final level evidenced is the cybernetic or post-industrial level. It is characterized by integrated technological systems. This society straddles the industrial level and the new technology/information level. At this point communications technology has become the major industrial and social influence. The technology has become a major determinant of culture and societal values. Technological literacy for the population implies that technology education must become a major component of general education.

Purpose of Technology Education

The purpose of technology education is to study the realities generated by humans. The student gains several benefits from technology education. There is gain in comprehension of technological progress, in a content base to amplify work in other disciplines, and there is a headstart on technological literacy (Lauda and McCrory, 1986). A technologically literate student can contribute to the advancement of technology, is

better able to assess current and future technology, is better able to control technology, and is better able to adapt to a changing world (Stashak, 1981 in Daiber and LaClair, 1986).

As a result of a 1980 American Industrial Arts Association research project, Dugger, Barmes and Pinder (1985) stated the following purposes of technology education:

1. know and appreciate the importance of technology.
2. apply tools, materials, processes, and technical concepts safely and efficiently.
3. uncover and develop individual talents.
4. apply problem solving techniques.
5. apply other school subjects.
6. apply creative abilities.
7. deal with forces that influence the future.
8. adjust to the changing environment.
9. become a wiser consumer.
10. make informed career choices.

Based on The Teaching of Technology by Deforge (1972) and the conceptual framework that (i) all countries undergo an evolution of technological growth and development and (ii) technology education in a

society closely reflects the society's technology, Todd (1985, p.20) stated four purposes of technology education:

1. Technology and social-cultural education: the polytechnic (multidisciplinary) approach. School should not be cut off from society, particularly the world of work, but students should be taught how to fit within a particular social system. Activities would include environmental and futures studies.
2. Technology and people: group work. The main purpose is for students to find their place within the group in terms of abilities, ambitions, and knowledge. This could be accomplished with mass production and student enterprise.
3. Technology and the interdisciplinary concept: application and synthesis. Use and integration of different technological systems to solve technical problems through the project approach is recommended. Student research and synthesis of knowledge and techniques is the desired outcome.
4. Technology and disciplinary: the analytical approach. For this purpose subjects retain their traditional separation. Knowledge and skills are

applied to discrete subjects such as electronics.

The Jackson's Mill project developed a Mutual Interaction Model (Figure 3) to deal with the interaction between domains of knowledge and what they call Human Adaptive Systems. The domains of knowledge exist in the humanities, sciences, and the technologies with a fourth domain, formal knowledge (math, language, linguistics, and logic) serving as the glue that allows them to exist individually and as interactive elements.

The Human Adaptive System is based on the notion that humans, like other biological life forms, adapt to new situations. Human adaptive systems - ideological, sociological, and technological - exist in a man made and a natural environment. Change, as a result of interactions between two or more components or elements of the system, is the only constant. Jackson's Mill concluded that the purpose of technological education should be to provide for human adaptability to those changes.

ITEA (Technology education: A direction for the profession, 1985) developed a specific set of goals for technology education. They are:

1. provide an organized set of concepts, processes,

Figure 3 Mutual Interaction Model
Jackson's Mill Curriculum Project

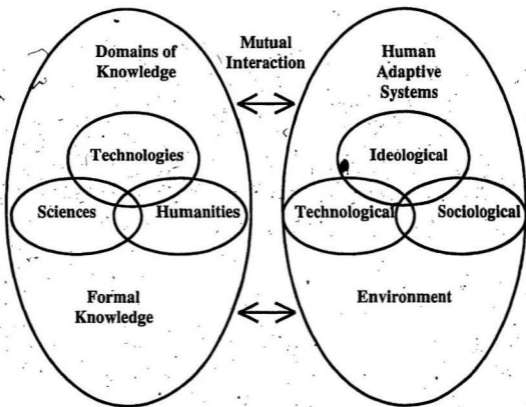

Figure 3 Mutual Interaction Model

and systems that are uniquely technological.

- 2.. provide fundamental knowledge about the development of technology and its effect on people, the environment and culture.
3. provide instructional content from one or more of communications, construction, manufacturing, and transportation.
4. assist students in developing insight, understanding, and application of technological concepts, processes and systems.
5. provide students with experiences in applying tools, materials, machines, processes, and technical concepts safely and efficiently.
6. provide students with opportunities to develop skills, creative abilities, positive self-concepts, and individual potentials in technology.
7. develop student problem-solving and decision-making abilities involving human and material resources, processes, and technological systems.
8. prepare students for lifelong learning in a technological society.
9. provide activity-oriented laboratory instruction with students reinforcing abstract concepts with concrete experiences.

10. provide a combined emphasis on "know-how" and "ability-to-do" in carrying out technological work.

In addition, technology education may contribute to a value system that includes values for relationships with people, for maintaining the environment, for work roles, for continuing education, for appreciation of creativity, and for worthy use of leisure time (Daiber and LaClair, 1986). This value system would help students make mature decisions regarding interrelationships of social, technological, and ecological systems.

Technology education is significantly different from industrial education. Industrial arts implies the study of industrial processes and systems; technology education implies the study of technological systems (Sutton and Carter, 1986).

The rationale of technology education is the study of technology in a post industrial society but the rationale of industrial arts is the study of industry for an industrial society. The objectives of technology education are development of technological literacy and techno-social skills while the objectives of industrial arts are the interpretation of industry, development of

arts and craft skills, and development of pre-vocational skills. Technology education is structured around technological adaptive systems but industrial arts is structured around drawing, woodworking, metalwork, and electricity. Finally the content of technology education is technology, but the content of industrial education, is material based (Daiber and LaClair, 1986).

The Development of Technology Curriculum Models

The first effort at technology curriculum, A Curriculum to Reflect Technology (Phillips, 1985) cited above, led to a variety of efforts throughout the United States. One of the definitions closest to modern definitions of technology education was put forward by Donald Maley at the University of Maryland (Phillips, 1985). He proposed student activities organized around investigation, exploration, analysis, testing and the use of tools and materials to solve problems. Other projects included the American Industry Project (AIP), and the Industrial Arts Curriculum Project (IACP). The IACP program consisted of three courses, the World of Construction, the World of Manufacturing, and the World of Communications.

A product of Jackson's Mill was a Universal Systems

Model (Figure 4) as a basis for curriculum development. This model organizes the 'systems' concept of human adaptive systems. It suggests that humans use a systems approach when adapting to new situations. Inputs include people, knowledge, materials, energy, tools, capital, time, and finance. These vary with different people and situations. System processes include technical means and knowledge of technical means or 'technology'. The technical means are the processes or the 'scheme of actions and practices' used to perform standardized operations. The outputs are the goals to which inputs and processes were applied.

Human technical endeavours have four subsystems (Figure 5): communications, construction, manufacturing, and transportation (see also Hesel and Jones, 1986). These subsystems exist in a complex web of interrelationships.

Each of these subsystems has unique goals and practices. Each is continually being affected by the natural/socio-cultural environment, as well as the intellectual processes of people with varied backgrounds. Each subsystem is often subject to a managed productive system with unique productive and managerial processes.

Figure 4 Universal Systems Model

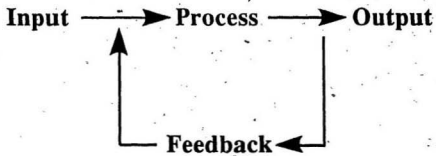

Figure 4 Universal Systems Model

Figure 5 Human Technical Endeavours Subsystems

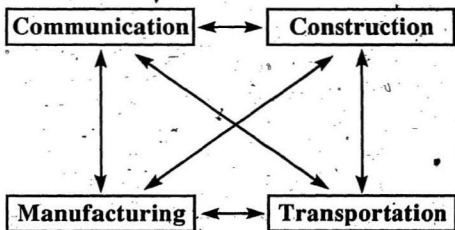

Figure 5 Human Technical Endeavours Subsystem

The monograph Technology Education: A Perspective on Implementation (1985) responded to Jackson's Mill with a model for curriculum development (Figure 6). It provided a model for technology education at all levels of school.

At the elementary level, Learning Reinforcement and Technological Awareness, the model would provide students with fundamental concepts, enrich science, math and language experiences, allow students to work with tools, materials, and technological processes, and allow students to develop technological awareness.

At the junior high level, Orientation and Exploration, the model provides explorations in the four broad content areas. Students are provided with experiences to assist in making informed and meaningful educational and career choices.

At the senior high level, Preparation in Technology, there are three objectives: Preparation for college or post secondary education, preparation for vocational education, and preparation for lifelong learning and technological adaptability.

In order to identify the content structure of technology education, one must:

1. Identify the dimensions of the study of technology.

Figure 6 ITEA Curriculum Model

Grades 9 - 12	High School Goal: Preparation in Technology
Grades 6 - 9	Middle School or Junior High Goal: Orientation and Exploration
Grades K - 6	Elementary School Goal: Learning Reinforcement Technological Awareness

Figure 6 ITEA Curriculum Model

2. Recognize technology based content.
3. Select appropriate learning activities to reinforce technological concepts.

Content of technology education programs must be chosen so as to balance the cognitive, affective, and psychomotor domains of learning and organizers such as themes, principles and generalizations. The systems model has become the organizing theme for technology education content (Lauda and McCrory, 1986).

Helsel and Jones (1986) described a model for structuring content based on the four universal systems of communication, construction, manufacturing, and transportation (Figure 7). The model provides a balance between technical, or 'doing', and technological, or 'knowing', activities.

Developing Technology Programs

Dugger (1985) offered the following guides for developing program/course content for technology education:

1. It uses an organized set of concepts, processes, and systems which are uniquely technological.
2. It involves fundamental knowledge about

Figure 7 Content Model for Technology Education

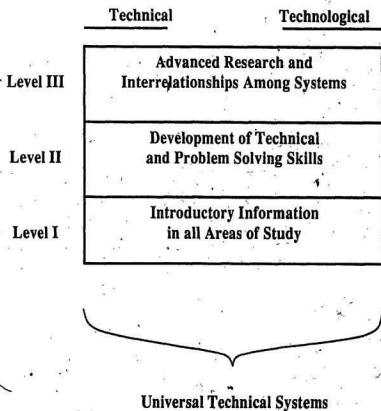

Figure 7 Content Model for Technology Education

technology development and its effects on people, the environment, and culture.

3. It uses instructional content from one or more of the following areas:
 - communications
 - construction
 - manufacturing
 - transportation
- A: It assists students to develop insights, understanding, and applications for technological concepts, processes and systems.
5. Students use tools, materials, machines, processes, and technical concepts safely and efficiently.
6. Students develop skills, creative abilities, positive self concepts, and individual potentials in technology.
7. Students develop problem solving and decision making abilities involving human and material resources, processes, and technological systems.
8. It prepares students for lifelong learning in a technological society.
9. It uses activity oriented laboratory

instruction to reinforce abstract concepts
with concrete experiences.

10. It combines emphasis on 'know how' and
'ability to do' for technological work.

Peterson (1986) suggests that an elementary program
should contain the following:

- K technology that we see and use every day
- Gr1 technology in the home
- Gr2 technology in the community
- Gr3 technology in the world
- Gr4 technology and history
- Gr5 technological and natural systems
- Gr6 how technological systems and devices work.

The ITEA content models for junior high, or middle
school (Figure 8) and senior high school (Figure 9) are
based on the four universal systems: communications,
construction, manufacturing, and transportation.

Middle school is defined by Bame (1986) as a
transition period for the early adolescent and as such
is in need of special consideration. He favors a
curriculum which is exploratory and broad but
fundamental and interdisciplinary. It should also be

Figure 2 ITEA Middle School Content Model

GRADES	RECOMMENDED COURSES	TYPE OF COURSES
8 - 9	Communication System Construction System Manufacturing System Transportation System	Elective courses each a semester in length.
6 - 7	Introduction to Industrial and Technological Systems	Required course, a semester for all students.

Figure 8 ITEA Middle School Content Model

Figure 9 ITEA High School Content Model

Grades /	Course	Type of Course
9 - 12	<u>Communication</u> Graphic Systems Electronic System Media System	Elective Courses, one or two semesters in length.
	<u>Construction</u> Planning and Design Constructing and Servicing Structures Electro/Mechanical Systems and Servicing	
	<u>Manufacturing</u> Materials and Processes Designing Products for Manufacture Manufacturing Production Systems	
	<u>Transportation</u> Technical Elements of Planning and Design for Humans and Goods Transportation Systems	

Figure 9. ITEA High School Content Model

vertically integrated and understanding of the student. The curriculum should provide socialization aspects to prepare students to enter adult society, and it should provide a transitional function to allow students to move from elementary to high school.

According to Daiber and LaClair (1986) High School programs should:

1. Further develop students' understanding of tools, materials, and products that are part of the technological era.
2. Involve cognitive, psychomotor and affective learning experiences through projects and experiments, in which students interact.
3. Allow students to examine social problems that are induced by technology.
4. Examine cause and effects of proposed technological changes.
5. Increase students' knowledge of the effects of technological change in the past, present, and future.
6. Aid students to develop sound assessment of appropriate technologies for local and global use.
7. Better equip students to cope with cultural change caused by technological advancement.

8. Diversify students' skills in the universal technical systems (communications, construction, manufacturing, and transportation).
9. Contribute to the development of technological literacy within society.
10. Participate in multidisciplinary activities within the school curriculum to illustrate the relationship of technology to other subject areas.

An alternative schema has been offered by Swyt (1986, and 1987). This schema includes all technological systems, not just the four universal systems of manufacturing, construction, communications, and transportation. Instead, technology is divided into three major systems (Figure 10). Information Communications Systems include technologies of all methods of communications. Physical Systems include power and energy, manufacturing, transportation, and construction technologies. Bio systems include agriculture and health and medical technologies. All systems use the seven basic resources of technology: people, information, energy, tools and machines, materials, capital, and time.

Figure 10 Model of Technology Education based on
Swyt's Schema

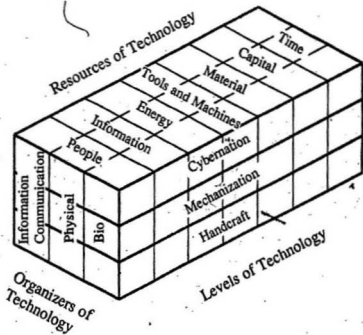

Figure 10 Model of Technology Education based on Swyt's Schema

Standards for Implementing Technology Programs

Dugger developed a set of standards to evaluate existing programs or to develop new programs. The standards actually consist of "descriptive statements established by key professionals and used as a model to assess the degree to which a program meets qualitative and quantitative characteristics of excellence" (Dugger, Barmes and Pinder 1985, p. 8).

These standards have four main characteristics. One, use of the standards is voluntary. Two, they are primarily designed for developing education programs in technology for secondary schools. Three, these standards are applicable to post-secondary technology education programs. Four, the standards contain 241 measurable statements which focus on 10 major topics: philosophy, instructional program, student populations served, instructional staff, administration and supervision, support services, instructional strategies, public relations, safety and health, and the evaluation process.

Use of the standards to assess a program or to develop a new program offers a number of benefits. Identification of weaknesses should allow improvements in instructional programs, teaching methods, and

facilities. The evaluation will increase the awareness of the general school staff concerning the role of technology education.

Use of the standards is a systematic process. Step one, planning the assessment, includes selection of the program to be assessed, selecting the assessment team, and choosing the evaluation method. Step two, conducting the assessment, involves comparing the program to the selected standards. Step three, reporting, itemizes the strengths and weaknesses of the program. Finally, step four requires implementing a strategy to correct deficiencies. This also involves monitoring the progress of changes.

Elements in Implementation Strategies

A number of issues must be addressed before a new program can be implemented. Maley (1960 and 1987) described a number of implementation issues identified by the AIAA. These issues, centered around the unit approach, were advanced preparation, introduction of the unit, student research, construction activities, the seminar, and evaluation.

Advanced preparation involves identifying and locating resources, identification of class type,

identifying the number of startup classes, and setting teacher qualifications, course content, and type of facility. Other considerations are class size, student ability, and program cost.

Introduction of the technology unit primes the student for all other activities. Approaches include films, 3-D models, slides, and transparencies or pictures. The only pre-unit instruction generally needed is shop orientation including general practices, course outlines, safety policies, and development of general operational skills for planning. Tool skills can be developed as needed or at specified times. Planning and teacher enthusiasm are two of the key items in ensuring acceptance by faculty, students, and parents.

Student research will be facilitated by providing them with as broad a range of resources as possible. Libraries, databases, industry resources, and community resources are available. Students need to plan enquiries and write them clearly and concisely. Teacher help may be needed for topic selection and amount and quality of research. Any student's letters requesting information should be on the school letterhead and have the teacher and school as the return address.

Construction activities will often be varied and usually take up 60-70% of laboratory time. Problems related to those activities are similar to those from a regular shop program.

The seminar is used to provide an overview of the technology module for all students, while allowing each to pursue an indepth project. Students present information to their peers and learn how to interact in a more formal setting. Students should use notes, use visual aids, should practice and use a standard delivery technique.

Evaluation should include both written and oral reports and should be based on plans, laboratory performance, constructions, written seminar reports, and oral presentations. Evaluations should be based on the program goals and objectives as well as the student's performance.

Some International Curriculum Projects

Technology programs are varied in nature and scope consistent with the nature of technology. This applies to other parts of the world as well as to North America. Many European countries use a core curriculum that includes communication and language skills, mathematics,

science, and technology, social and environmental, understanding, vocational studies, physical and mental recreational activities, creative arts, and interpersonal skills (Campbell, 1988).

Benson (1988), quoting from a 1983 UNESCO study of technology education in 37 countries, stated that there was a great deal of commonality within the programs. Technology education was generally considered to be part of general education, promoted a breadth of technical development in students, and was most frequently offered to young adolescents. The study also showed that as countries became more developed a higher value was placed on technology education.

The British Craft, Design, and Technology (CDT) program is the equivalent of industrial arts/technology education in Canada. The central aim of CDT is to "...develop those complex skills and abilities needed to exercise control over the quality of the environment." (Carter and Culberson, 1988, p. 28). The student must identify, examine and solve problems using tools and materials. A great deal of emphasis is placed on research, design and technology. The three areas of study that are integral to CDT are control, energy, and materials. Other areas regularly addressed are graphic

and associated modelling skills, craft skills, health and safety, cultural and historic perspective, values and attitudes, and communications.

The major philosophy of the Russian polytechnic program since the late 1950's is that all students should know work and the fundamentals of mass production (Nee, 1988). Students at the secondary level are taught the general scientific foundation of modern production and are involved in socially useful productive tasks.

There is no Chinese equivalent to industrial arts/technology education, but vocational education exists as vocational and technical programs. The 13th Congress of the Chinese Communist Party, meeting in 1987, prescribed a mandate for educational reform. The purpose of this reform was to develop a technology program to meet the needs of Chinese business and industry (Sredl, 1988).

Since World War II, Japan has had an industrial education program which is strongly modeled on the American system. In lower secondary school (junior high) all students study (8% of time) practical arts. This is a rough equivalent of industrial arts, agriculture, and home economics. Vocational education is available in comprehensive high schools and in

technical high schools. A new curriculum project has been implemented to provide students with experiences in newer technologies, particularly those relating to computers.

Over the next five years a 35 hour course will be implemented that includes computers and society, computer hardware, computer software, and applications in wordprocessing, spreadsheet, database, CAD, and CAM (Stern and Matsuda, 1988).

A review of programs in North America revealed that the effort expended at Jackson's Mill and by the ITEA are providing valuable guidelines for the development of programs. Most programs are based on the universal systems of communications, manufacturing, construction, and transportation. All programs promote technological literacy, and provide technology learning activities that require a mix of theory, research, and practical activity.

Selected North American Programs

John Hanson Middle School, Maryland

The John Hanson Middle School program has five main goals:

1. Acquire a better understanding of technology
2. Understand that technology is applied mathematics and science.
3. Develop better language skills through practical oral and written communications.
4. Create an awareness of the social consequences spawned by technological change.
5. Achieve a better understanding of his/her self and their relationship to others in an industrial/technological society." (Smith, 1987, p. 26)

This year long program, designed for 20 to 25 eighth graders, involves: four to six weeks of hand and machine tool skill activities involving construction of a simple project to prepare for the remainder of the program; research both in and out of school on a selected topic; laboratory and shop activities including sketching, CAD design, and construction of the project; and seminar presentation by the students on the results of each student's project. Technology projects have included a spinning wheel, a nuclear reactor, a typewriter, a computer, a sewing machine, a hydrofoil, and a monorail.

According to Smith (1987), students are encouraged

to answer such questions as :

Your ... (technology topic) helped humans solve a problem in which of the following areas: defense?, daily life?, transportation?, communications?, used what power source?,

Describe how topic fits into the evolution of technology. ... correct place on a timeline... (p. 28)

The seminar focuses on three topics to be addressed by each student: Function of Technology, Social Significance of the Topic, and Evolution of the Technology Topic. During the Function of Technology seminar students are encouraged to establish the math/science links of their chosen project by answering questions such as: Explain how things work, identify all integral parts, identify the scientific principle for each part, and prepare simple visuals to explain the function of each part.

Laboratory procedures are evaluated by allocating a "paycheck" of \$50 to each student. Infractions of school rules, lab rules, and safety rules result in deductions. At the end of the week the "paycheck" is redeemed for the lab procedures grade.

Grace Atlanta High School

The Greece, New York, Grace Athena high school technology program (Listar and Schiffman, 1986) was converted from the school's very active, seventeen year old, four cluster industrial arts program during the period from 1984 to 1986. The technology program is based on the curriculum guide for junior high technology programs for New York State in 1984.

Teachers in each school implementing the program are to develop TLAs (Technology Learning Activities) to meet the unique concepts and objectives of each module. Each TLA activity sheet states:

1. What module the sheet is written for.
2. The activity and concepts the activity covers.
3. An overview of the activity.
4. Student/teacher activities by class period.
5. Constants that are infused in the activity.
6. An evaluation plan for the student and the TLA itself.

TLAs developed by the Greece teachers include: For Module T-1, "Getting to Know Technology", involving technology process skills, activities include layout and measurement, cutting and machining, forming and molding, fastening, and coating and finishing.

For Module T-2, "Resources Needed for Technology", activities center around time, time and machines, knowledge, materials, energy, people, and capital.

Module T-3, "Using Technology to Solve Problems", requires each student to explain the solution to one of the problem solving activities. One of the unique aspects of the TLAs in this module is the use of 'Technology Money' to represent the value of tools and resources. The value of each depreciates with use and with time, encouraging the development of the 'cost of technology' concept.

Module T-4, "Systems and Subsystems", TLAs require students to design and build an open or closed loop system using technology processes. The system and any subsystems must be identified.

The other technology modules to complete the program are:

Module T-5, "How Technology affects People and the Environment"; Module T-6, "Introduction and Review"; Module T-7, "Choosing Appropriate Resources for Technological Systems"; Module T-8, "How Resources are Processed by Technological Systems"; Module T-9, "Controlling Technological Systems"; Module T-10, "Using Systems to Solve Problems"; and Module T-11,

"Technology and You: Impacts, Decisions, and Choices"
(Good, Feb: 1986, p. 8)

Implementation of TLAs is a factor in budgeting operational costs for the Grace Atlanta program. For each TLA implemented, costs are calculated by objectives covered, cost of materials per objective, and the number of students. Evaluation of students is based on 80% for meeting TLA criteria and 20% for a final technology exam.

The New York State Junior High program emphasizes understanding, using, and controlling technology and uses a delivery system designed to provide concrete, motivational experiences. Activities are designed to develop mental process skills for creative thinking, decision making, critical thinking, and problem solving. Technological learning activities are multi-disciplinary and cover biotechnology, information/communications technology, and physical technology (Good, 1986).

Students completing the series of modules are expected to demonstrate the following proficiencies:

1. Demonstrate an understanding of a technological system.
2. Apply conceptual knowledge to the solution of technical problems.

3. Demonstrate the correct care and use of tools and equipment to built and maintain technological devices and machines in developing an awareness of the impact of technology on their personal and working lives.
4. Analyze and develop methods of using technology to benefit human-kind through planning, designing, illustrating, modeling, and producing.
5. Design and produce a product or device to solve a given technical problem.
6. Read and correctly interpret technical information including diagrams, symbols, Flow charts, and blueprints.
7. Describe the combination of subsystems which perform a specific function within given systems of a simple prqduct through the use of a block diagram.
8. Describe a variety of career opportunities in technologically related fields including entry level training requirements.
9. Demonstrate the ability to formulate and make decisions as consumers of technology." (Good, 1986, p. 9).

The New York State High School Program

The high school program, slated to be fully operational by 1990, is intended to assist students to develop transferable skills for work or home situations, and to enable students to explore occupational interests and abilities prior to specialization. All students in occupational education must take one unit of credit in "Introduction to Occupations".

The introduction contains 26 modules which may be combined in any fashion with the proviso that all students take "The Working Citizen" and "Personal Resource Management" as two of the four required modules. These two modules are designed to develop real world skills in terms of integration into society and management of time and personal resources.

Other modules include introductions to basic systems for manufacturing, construction, transportation, energy, communications, electricity, electronics, and drawing.

Following the required introduction, students may choose a variety of minimum course sequences: two three unit sequences, one five unit sequence, or one three unit technology and one five unit English and social studies sequence.

Students are expected to develop core competencies in personal development, social systems, information skills, resource management, and technology. Technology competencies are required for concepts of technology, developing technologies, applications of current and emerging technologies, use of basic tools and equipment, work related health and safety, and personal safety. The high school program continues to stress relationships between technology and other disciplines including math and science (Good, 1986).

Triad High School, Troy, Illinois

The Triad Education Cluster (TTEC) established in 1980 in Troy, Illinois uses a three level approach to technology education (Gerstenecker, Daiber, Moore, and Conley, 1987). The program is based on the following goals:

1. Provide an introduction and exploration in the areas of technology to illustrate how people use information, tools, materials, processes, and energy to satisfy their needs and wants.
2. Develop sound technical skills which will prepare students to enter a vocational or technical school,

college or employment after graduation.

3. Group the content area in a cluster to illustrate how drafting, electronics, and production interrelate in a system.
4. Diversify students' skills in the major contents of technology (production, energy, utilization/ transportation, and communications).
5. Generate group activities in which students will learn to think and work together.
6. Better equip students with skills and abilities to seek jobs which will develop the future.
7. Aid in the overall educational experience of students to enable them to better cope with cultural change caused by technological advancement.
8. Remain relevant to the growth and development of technology by eliminating and adding new subject materials (Gerstenecker, Daiber, Moore, and Conley, p 23-24).

The TTEC program is a flexible three level program with multiple courses offered in each level (Figure 11). Level 1, Technology Education I, is an introduction to communications, energy utilization, production, and

Figure 11 TTEC Course Structure

<u>Introduction and Production Level</u>	
Technology Education I	
<u>Skill Development Level</u>	
Drafting II Technology Education II Electronics II	
<u>Technical/Social Development Level</u>	
Drafting III Production Systems I Electronics III	Drafting IV Production Systems II Technological Systems Electronics IV

Figure 11 TTEC Course Structure

transportation.

Level 2 offers skills development courses in Drafting II, Technology Education II (polymers and metals), and Electronics II:,"

Level 3, a technical/social development level, offers three streams of courses based on the three courses in level 2: Drafting III, Architectural Drafting, and Drafting IV; Production Systems I and II, Plastics, Welding and Advanced Welding, and Technological Systems and; Electronics III and IV.

Flexibility comes from a number of built-in features. Instructors constantly research and identify technological developments and trends and modify course content and activities to reflect those developments without changing course names. Courses are kept relevant without major administrative acceptance and scheduling problems. This also prevents problems for students who are already in the program.

Throughout the program, emphasis is placed on the math/science/society relationships of technology. Activities range from paper airplane contests for transportation students in the Introductory Level to robotics and mass production projects in the Technical Social Development Level.

Newport News Public Schools, Norfolk, Virginia

The Newport News technology education program is based on four guidelines of the Department of Education of Virginia:

1. Competencies are specified to students prior to instruction.
2. Competencies are role relevant and are derived from the profession.
3. A system exists for documenting student competencies.
4. Criterion referenced measures are developed for each performance objective." (Cummings, 1987, p. 15).

A competency-based curriculum has been developed from these guidelines. Performance objectives exist for the delivery of the program by teachers and for the learning outcomes for the students.

The Middle School curriculum beginning in the sixth grade is an activity based program entitled "Introduction to Technology". Activities include: production - plastics forming, woods and metals processing; communications - photography, graphic arts, technical drawing, and electricity/electronics; career exploration - titles and job descriptions as well as

tools for communications, construction, power and transportation, and manufacturing; and a course familiarizing students with the high school program.

The seven and eighth grade program, "Exploring Technology", uses a 'unit' approach. Students are required to select a problem and research a solution as part of the activity. Product development and production are covered as is an introduction to pick and place robotics.

The high school curriculum provides a number of technical courses. Ninth grade offers construction, communications, and power and transportation. Later courses include Basic Technical Drawing, Electronics, Woods Technology, Metals Technology, Graphic Communications, Computer Electronics, and Principles of Technology.

Part of the rationale for the approach taken in this program is current thinking that a good foundation in technological basics will lessen the need for technical retraining, and will make people more technologically adaptable. Also part of this rationale is recognition of the value of a project or activity based program for learning technological skills and strategies.

Pittsburg Middle School, Pittsburg, Kansas

The Pittsburg Middle school's "Explorations in Technology" modular program allows considerable flexibility (Iley, 1987). The program consists of 20 self-directed, totally self-contained modules, each complete with all equipment, materials, instructions, and daily assignments. Each module is representative of a technology area and is based around one major piece of equipment.

Each module is organized around these logical components:

- a. Computerized pretest/post-test.
- b. Specified reading assignments.
- c. Related information using a variety of media.
- d. Activities }

Modules include Radio Communications, Line Production, Space/Flight, Production, Small Gasoline Engines, Research and Design, Electricity/Electronics, and Think Tank. Activities range from CNC production to wind tunnel testing of student produced cars.

Prior to entry into the program, students are given an orientation to the organization and management of the course; an introduction to, and an overview of the technology, its history, and how it affects the world;

measurement; safety; and media and computer operations.

The program is managed with the aid of a computer pretest/post-test for each student which is automatically entered into the student's record. A student management system is used to keep attendance and daily activity records. The modular activity centers use a call light system to control student movement. Each facility has a light above it which is turned on by the student when problems arise. Students know "where they should be, what needs to be done, and that assistance is available without leaving the module" (Iley, 1987).

Chicago Public Schools, Chicago, Illinois.

Chicago public school technology programs are based on the four systems of humanly described by the Illinois Plan:

1. Communications.
2. Production.
3. Transportation.
4. Energy Utilization (Tobin, 1987, p. 7).

The program was field tested for one year in the

Fenger High School. Curriculum development was carried out by public school teachers for the following:

1. Production Technology
2. Communications Technology
3. Transportation Technology
4. Consumer Electronics III-IV
5. Basic Machine Trades
6. Construction Math/Blueprint Reading
7. Drafting/Communications
8. Computer Aided Drafting
9. Production Cabinetmaking.

An applied science course, Principles of Technology, offered to grade 12 vocational track students provides an understanding of principles of technology and associated mathematics. The course was developed by a consortium of 32 states. It is designed to help students continually adapt to the demands of a changing workplace. The course utilizes a broad base of delivery methods including various media, demonstrations, and hands-on activities. In addition, it meets some of the requirements for increased science content required for high school graduation (see also the Wood River Program below).

Wood River Industrial Technology Program, Idaho.

The Wood River Industrial Technology program provides technology exploration activities for a variety of courses (Thode, 1985). The grade seven to grade twelve program begins with a six week Introduction to Technology course for seventh grade (Figure 12).

Grade 8 - 9 students must select two areas for each year. This allows them a choice of four of the seven options. Throughout the program instructional materials are delivered using a variety of technologies including computer, video disk, and satellite downlinks. Emphasis is placed on hands on activities.

Manufacturing Technology is based on a student mass production project (Figure 13). The first nine weeks are devoted to a variety of industrial processes used with woods, metals, and plastics. The second half of the course is used to create and operate a student corporation.

Technologies introduced include pick and place robots and CAM, as well as the social and industrial implications of using those devices and methods.

Materials Processing Technology is organized around industrial processes for materials instead of the traditional wood, metals and plastics (Figure 14).

Figure 12 Wood River Technology Program

<u>Grade</u>	<u>Course</u>
<u>10 - 12</u>	Advanced Technology
<u>10</u>	Principles of Technology
<u>8 - 9</u>	Applied Science
<u>8 - 9</u>	Building Construction Technology
<u>8 - 9</u>	Power and Transportation Technology
<u>8 - 9</u>	Manufacturing Technology
<u>8 - 9</u>	Materials Processing Technology
<u>8 - 9</u>	High Technology
<u>7</u>	Introduction to Technology

Figure 12 Wood River Technology Program

Figure 13 Wood River Manufacturing Technology Course

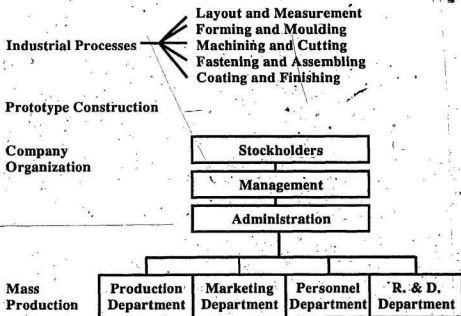

Figure 13 Wood River Manufacturing Technology Course

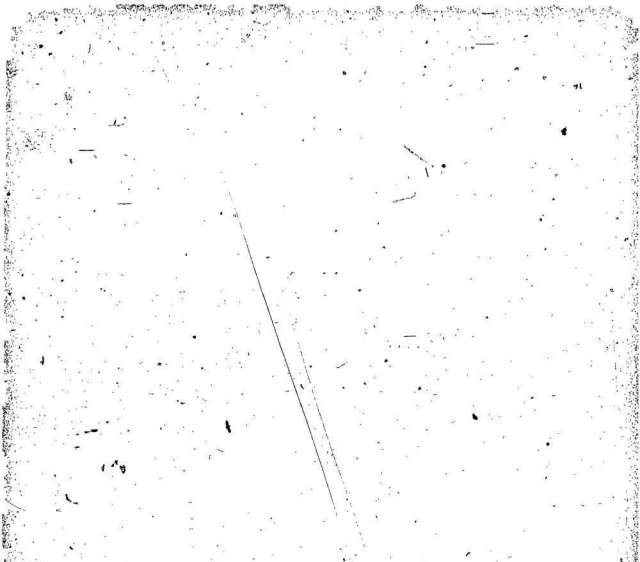

Figure 14 Wood-River Industrial Processes-Course

0

Industrial Processes

Layout/ Measure	Forming/ Moulding	Machining/ Cutting	Fastening/ Assembling	Coating/ Finish
Ruler Scale SI Metric Go/No Go	Sheetmetal Punch Press Foundry Injection	Sawing Shearing Lathe Milling Abrading	Gas Weld Arc Weld Mechanical Adhesive	Dip Coat Spray Fluid Plating

Figure 14 Wood River Industrial Processes Course

Students also perform materials testing for compression strength, tensile strength, thermal conductivity, elongation, impact strength, thermal expansion, and shear strength. Students use a CAD process to design a product using the material and processes of their choice. The final component of the course is construction of the product.

Communications Technology is a four part course. Drafting and design, photography, telecommunications, and graphic arts is a multi-activity program that integrates computer technology. Technologies used by students include: manual drafting and CAD; black and white and colour photography and processing, laser holography and optics, and process camera; online database access using phone lines, fiber optic links, and satellite links using the school's satellite earth receiving station; receiving, taping, and distributing satellite broadcasts through the school's video editing and distribution system, and development of video instruction modules for technical topics of interest to students.

Power and Transportation Technology is a three part course covering small engines, electricity/electronics, and alternative energy. Students strip down, rebuild,

and run a small engine; perform digital and analog experiments; and perform a variety of experiments with solar, wind, geothermal, hydroelectric, and other alternative power sources. These are generally hands on activities involving the use of materials, processes and tools.

High Technology is a semester long course designed to provide more in-depth study of "high tech" activities in other courses. These activities include: robot/computer interfacing, writing robot controlling software, assembling robot kits, robot vision, and robot sound activation; laser use with fiber optics, spatial filters, and laser scanning; and in-depth activities in CAD, CAM, voice control (input/output), computer vision, and digitizing.

Applied Science is a year long course team taught with a science instructor. Designed for students who are experiencing difficulty with the regular science program, it offers a high level of hands on activities and is highly success-oriented. Science topics are applied to real life situations. For example, the principles of the six simple machines are used to construct a mechanical model of a robot arm.

Principles of Technology is a full year course

based on the physical principles of modern technology. Figure 15 outlines the seven principles covered by the course.

Each of the units based on these principles cover four systems - mechanical, electrical, fluid, and thermal. The course has integrated math, science, and technology. Students may also receive math or science credit for this course.

Advanced Technology is full year course for students who wish to do advanced work in computer applications or in a specified high technology area. Previous students have installed the video studio, set up a satellite dish, and set up the laser lab. Activities also include presentations by experts.

The New Brunswick Program

Technology 100, the New Brunswick technology program, was prompted by current educational research and is based on the philosophy identified by the Jackson's Mill Curriculum Project, as well as the British Open University Technology Curriculum.

The 120 hour program consists of a 40-60 hour compulsory Foundation Module and two or three 30-40 hour modules. Initial module selections are Business Systems.

Figure 15 Wood River Principles of Technology Course

9

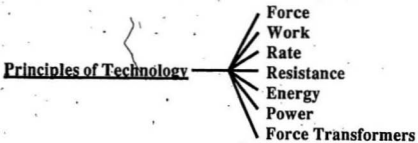

Figure 15 Wood River Principles of Technology Course

and Solutions, High Tech Living, and Exploring

Electronics Technology.

A rationale for the program is provided by the global technological changes and competitions, and the resulting demands placed on productive citizens. Technology is considered to be a major contributing factor to change in society, in lifestyles, in interpersonal relationships, in personal work habits, in the amount and frequency of career retraining, and in the quantity and quality of tools and artifacts used in daily life.

The program is based on theory and activity in that it requires students to "sample technological problems and attempt to solve them using technology" (Technology 100, p. 3). Two types of projects are provided for the program: informational projects (Figure 16), which require research and a written report from the student; and activity projects (Figure 17), which require the student to research, design, develop, test, and report on a product.

Evaluation of student work is based on mastery in practical courses; mastery level is determined by the instructor and is measured using a variety of testing

Figure 16 New Brunswick Information Projects

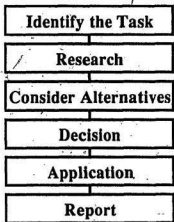

Figure 16 New Brunswick Information Projects

Figure 17 New Brunswick Activity Projects

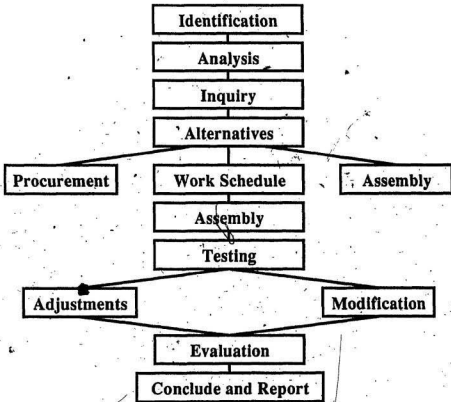

Figure 17 New Brunswick Activity Project

devices. Evaluation criteria include sufficiency of effort, work habits, attitudes, care of equipment, comprehension of practical and theoretical components, concise articulation and plausibility, information and application, and formulation of designs based on research.

The Foundation Module has the following objectives:

1. Identify and define systems and components found in technology.
2. Develop a strategy to administer the systems processes found in technology.
3. Find knowledge, synthesize information, and adjust the systems of technology.
4. Use technology to increase an awareness of individual potential in our technological world.
5. Understand the process of searching for explanations of technological phenomena.
6. Integrate knowledge and use skills acquired in other courses to develop strategies for dealing with technological challenges.
7. Set the stage for other technology modules.

These objectives are met by the following units of

study:

I. Overview of Technology. After completing this unit students should be able to describe technology in terms of systems models, characterize technology unique to their locale, discuss technological impacts as opportunities and delimiters for individuals, use common implements of technology in solving technical problems, and develop confidence and decision making skills for dealing with technology.

II. Information and Communication technology. Students determine the nature and composition of communications technology, use communications technology equipment in class activity (computer and modem), recognize the ability of communications systems to enhance man-man, man-machine, and machine-machine interaction, and have practical experiences with some of the limits placed on communications systems.

Included in the activities are telecommunications, graphic communications (CAD), word processing, spread-sheets, database, and machine control. Transmission methods include hard wiring, fiber optics, and satellite.

III. Physical Technology. Students describe physical technology system requirements, explain the

major concepts of physical technology systems, locate and use information to conduct physical technology experiments, are involved in problem solving to experience capabilities and limitations posed by the presence and absence of technology, and make decisions related to a variety of physical technologies.

Technologies covered include building construction systems, subsystems, and developments: energy analysis of construction sites using the HOTCAN R-2000 computer software, energy and power technology, including sources of energy, measuring and monitoring energy; transportation systems; and manufacturing systems including CIM.

IV. Technology and Life. Students review technology effects on society and health care technologies, explain the effects of technology on learning opportunities, understand how to use technology to enhance learning, and become familiar with emerging technology terms for agriculture, environment, biology, and health.

V. Technology and the Future. Students develop a perspective for viewing and participating in emerging technology, become familiar with terminology associated with emerging technology, perform activities to make

decisions on how to participate in a technology, and identify personal opportunities in technology.

Topics include technology and the future, technology and the environment, and consequences of technology.

The Business Systems and Solutions Module is based on the following goals:

1. To improve students' ability to communicate and work with small peer groups.
2. To develop the students' awareness of today's computer based technology.
3. To improve the students' understanding of modern day word processing.
4. To develop the students' confidence in using a word processor.
5. To develop the students' general knowledge and understanding of modern day word processing.
6. To help students gain knowledge and understanding of today's problems in business systems.
7. To help students develop their potential for solving business problems.

These goals are met by the following objectives:

1. Be able to operate a word processor.

2. Obtain a basic understanding of the capabilities and uses of word processors.
3. Understand terms commonly used with word processing programs.
4. Know the terms involved in developing solutions to business systems problems.
5. Acquire the ability to communicate with a group.
6. Have little difficulty working and co-operating with a small group in problem solving situations.

Students operate a word processor to perform a number of tasks; learn the definitions and descriptions of business systems, procedures, tools and analysis; and analyze a case study of a business system problem using the group approach.

The High Tech Living module is designed to deal with the impact of technology on the home, help incorporate new technologies in food preparation, develop student abilities in appliance selection and design of efficient work space, and to develop awareness of effects of food service industry trends on eating habits and lifestyle.

The module has the following objectives:

1. To describe energy efficient systems of work in the food service industry that may be transferred to the home.
2. To apply these systems of work to home preparation of food using multi-use ovens.
3. To identify the various kitchen appliances designed so individuals may save energy and time.
4. To design a criteria for the selection of multi-use ovens and compare and contrast features of various models.
5. To apply the techniques of combined microwave/convection cooking by preparing a meal for a specific lifestyle.
6. To plan a menu using an electronic cookbook evaluating the menu for nutrient content.
7. To create, using a computer assisted design program, an energy efficient kitchen, that uses programmable appliances and analyze its working area, traffic patterns and ergonomic features.

The Exploring Electronics module is based on the rationale that electricity has become a major component.

of daily life, and is involved in all forms of transportation, communications, tools, and energy use. In addition, electronics has become the major and unifying component of all technological systems.

The module's aims are to select relevant curricula to reduce the 'overwhelming' aspect of electronics communication in terms of the students' interactions with electronic technologies.

These aims are accomplished with the following objectives:

1. Identify electronic symbols and components.
2. Determine resistance values and tolerances from colour codes.
3. Measure resistance using an ohmmeter.
4. Construct simple resistive circuits with miniature components on a proto board.
5. Verify Ohm's Law using light-emitting diodes, resistors, and a voltmeter.
6. Identify electrical safety hazards.
7. Determine the effect of diodes in a circuit.
8. Determine the effect of transistors in a circuit.
9. Determine the operating characteristics of an AND gate using a 7408 IC chip.

10. Determine the operating characteristics of an OR gate using a 7432 IC chip.
11. Construct a free running clock using a 555 IC timer.
12. Construct and operate a digital logic probe.
13. Display an analog and a digital signal on a computer.
14. Determine the nature and extent of employment in the electronics field.

These objectives are covered in four units of study: The Basic Electric Circuit, Introduction to Solid State Concepts, Digital Concepts, and Perspectives on Employment.

Summary

Industrial arts began in North America at the turn of the century. There were a number of shaky starts, but it gradually grew to become an important part of the general education program in the United States and Canada. It provided the student with useful experiences aimed at developing the whole person and involved cognitive, affective, and psychomotor skills. The primary content of industrial arts was the material and processes, communications, and power and energy systems.

of industry. During the sixties, the technological revolution in the workplace, and later in all areas of society, produced a crisis in industrial arts. The content and methods of the program were no longer relevant. A number of curriculum projects were undertaken to make the program relevant. Eventually curriculum developments centered on technology education.

Technology education offers a comprehensive program with a purpose of producing technologically literate citizens. Organized around a systems theme, the program attempts to place technologies in a schema of technologies which shows interrelationships between technologies, effects of technologies on society and on the person. It shows the 'how to' as well as the 'what' of technology.

Two basic schema have been developed to show the relationships between technological systems. The first, developed by the ITEA, uses the universal technological systems of communications, construction, manufacturing, and transportation. This schema deals primarily with industrial technology. The second schema was developed by Swyt (1986 and 1987) and it encompasses all technological systems. The major systems are

information communications, physical, and bio. Physical systems incorporate ITEA's universal systems of construction, manufacturing and transportation. Both schema recognize that technological systems use seven basic resources: people, information, tools and machines, time, capital, materials, and energy.

Technology programs have been developed for many countries. These programs have several factors in common: They are delivered primarily to adolescents; they promote technological literacy across a broad spectrum of technologies; and they are activity based.

Chapter 3

Front End Analyses

When the study of the development of industrial arts and technology education programs was completed, the next steps in the development process of the "Define" stage were undertaken. These steps, generally described as the front-end analyses, included analysis of the learner, analysis of the concepts and learning tasks to be introduced, specification of instructional objectives, and development of criterion referenced test items. This chapter describes these steps of the development process.

Learner Analysis

A learner analysis was conducted to determine the characteristics of the target population relevant to the design of the instructional materials. The analysis was conducted by interviewing the Director of the Industrial Arts Program at Memorial University. A number of instructors for this program were also interviewed, including the target students' instructor for the previous summer's program. It was assumed that these characteristics had not changed over the past year.

General learner characteristics. Learners for this project came from the third level of the three summer Diploma of Industrial Arts program. These students are from the general population of university undergraduate education students at Memorial University. Most have completed two or more years of university, and are completing requirements for undergraduate degrees. Some are teachers returning for the summer session. It was assumed that they were mature, responsible adults.

Subject matter competence. Although these students have completed two thirds of the existing traditional industrial arts program, most have not had prior experience with computer related technologies. Current teaching staff indicated that many of these students were illiterate with respect to computer technologies.

Attitudes. It was expected that the learners would have a generally positive attitude towards technology since they had voluntarily enrolled in a special program dealing with technology (industrial arts deals with technology, and is, in fact, a subset of technology under the definition used here). During validation testing this turned out to be a correct assumption with one exception. Prior to commencement of the TLAs, some students expressed fears about using some of the equipment. These fears dissipated after commencement of the TLAs. Attitudes towards instructional format were

biased towards self directed activity. This tendency may be due to the historical activities-oriented nature of the industrial arts program.

Language. Language preferences ranged from conversational to semi-scholarly. For most students, language preferences were closer to the conversational end of the continuum. Many of the concepts and processes required the adoption of a new vocabulary.

Tool skills. Students did not have any deleterious physical handicaps, and given proper instruction were able to handle all equipment.

Concept/Task Analysis

Concept and Task analyses were used to break down the instructional content into components, and to analyze learner knowledge (concepts) and behaviors (tasks) required to achieve the terminal objective. They were also used to define the terminal objective and the enabling objectives.

Prior to the development of these analyses, discussions were held with the client to establish the general objectives for the course. The decision was made to create a course titled "Introduction to Technology". This course would place particular emphasis on three advanced technologies: (i) Computer Assisted Drafting, (ii) Robotics, and (iii) Desktop Publishing. Teaching the theoretical base for those technologies was considered essential. The course was to be, as much as possible, practical and activity based. This translated into a short theoretical introduction titled "An Overview of Technology" followed by a number of TLAs in the 3 major technologies already identified.

Concept analyses. Following those discussions, the concept analysis for "An Overview to Technology" was developed (Figure 18). It placed each technology in the proper family of technologies within a hierarchy. This hierarchy became the theoretical structure that glued

the technologies together.

Concept analyses were then developed for each of Computer Assisted Drafting (Figure 19), Robotics (Figure 20), and Desktop Publishing (Figure 21).

Figure 18

Concept Analysis for An Overview of Technology

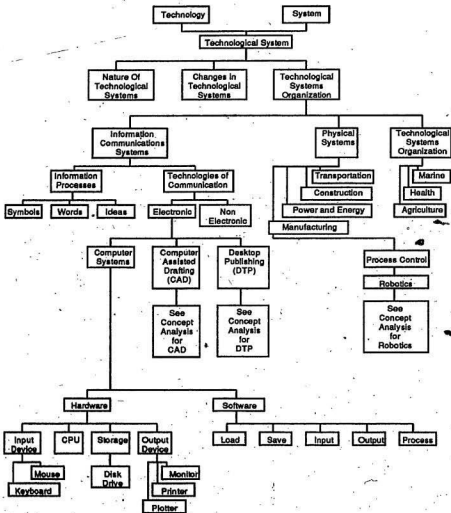

Figure 19

Concept Analysis for Computer Assisted Drafting

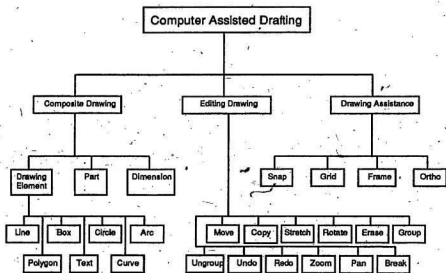

Figure 20

Concept Analysis for Robotics

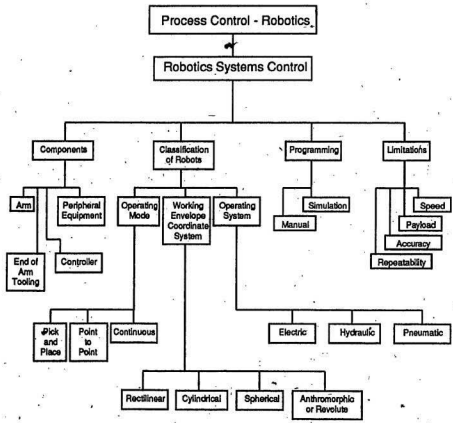
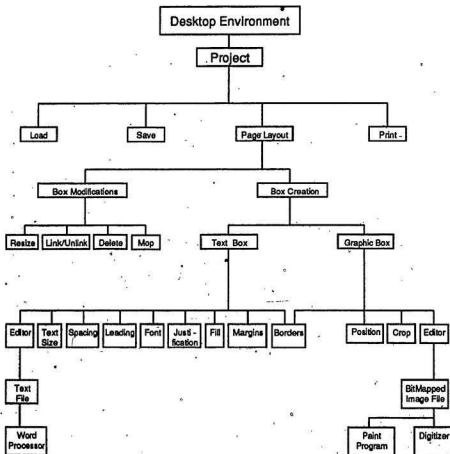

Figure 21

Concept Analysis for Desktop Publishing



Task analyses. Following completion of the concept analyses, task analyses were developed based on the concept analysis for each technology. A Task analysis was not identified for "An Overview of Technology". These analyses identified the particular activities for each technology, and were later used to help determine the equipment and facilities needed to teach the course.

During this time, a decision was taken to split the tasks for each technology into several logical sections. These sections created more manageable pieces of instruction, both for the instructor and for the learner. Each section became a Technology Learning Activity (TLA). This resulted in two CAD TLAs, three Robotics TLAs, and two Desktop Publishing TLAs.

Task Analyses were completed for Computer Assisted Drafting (Figure 22 and Figure 23), Robotics (Figure 24, Figure 25, and Figure 26), and Desktop Publishing (Figure 27, and Figure 28).

Figure 22

Task Analysis for Computer Assisted Drafting

TLA 1

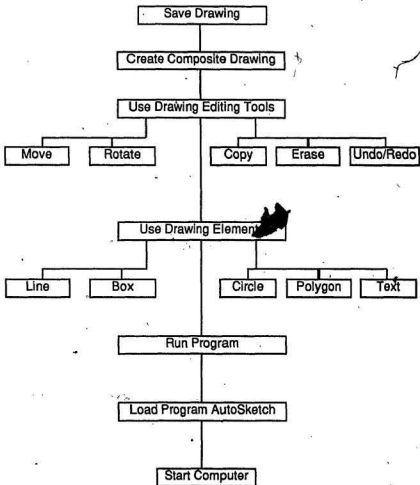

Figure 23

Task Analysis for Computer Assisted Drafting

TLA 2

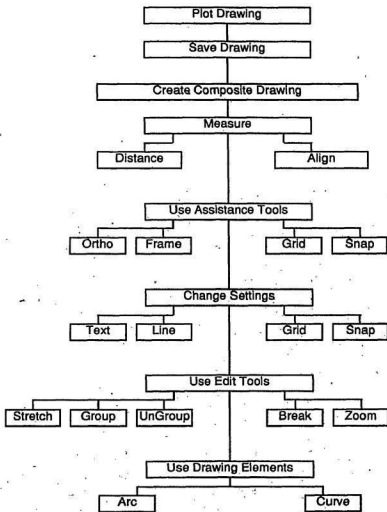
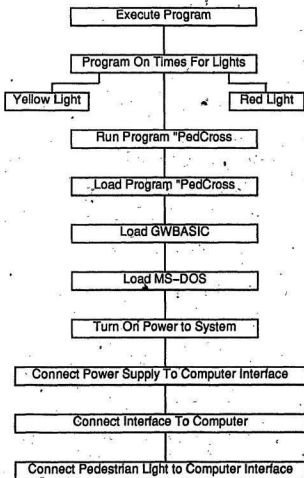

Figure 24

Task Analysis for Robotics

TLA 1



5

Figure 25
Task Analysis for Robotics
TLA 2

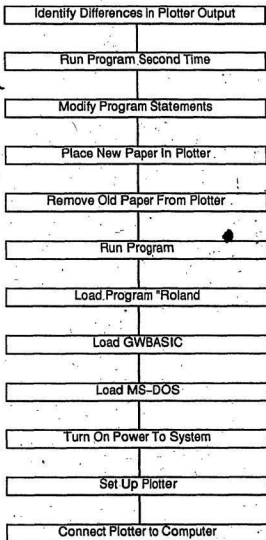

Figure 26

Task Analysis for Robotics

TIA 3

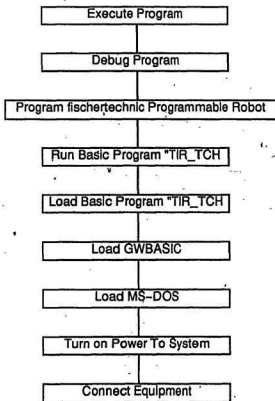

Figure 27

Task Analysis for Desktop Publishing

TLA 1

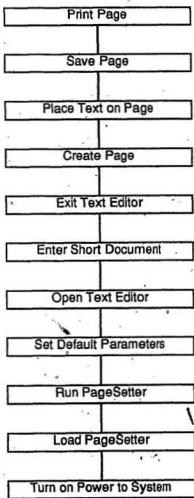
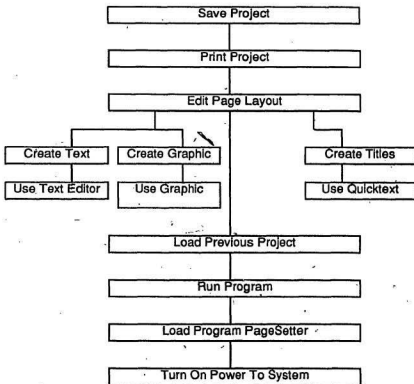

Figure 28

Task Analysis for Desktop Publishing

TLA 2



Instructional Objectives

Instructional objectives were written to transform task and concept analyses into statements of instructional goals. The instructional objectives formed the basis of the materials that were later developed.

Instructional Objectives are listed below for "An Overview of Technology", the two CAD TLAs, the three Robotics TLAs, and the two DTP TLAs.

An Overview of Technology

General Objective:

To provide an overview of technology and the development of industrial technology, and place the current industrial education program into that frame of reference.

Specific Objectives:

Upon completion of this activity, each student will demonstrate an understanding of the following objectives by scoring greater than 80% on the criterion referenced test.

1. Define Technology.
2. Draw a diagram of an open loop system model.
3. Draw a diagram of a closed loop system model.
4. List the three main groupings of technological systems.
5. State the two main parts of an electronic communications system.
6. State the four main parts of a computer hardware system.
7. State the five main parts of a computer software system.
8. Explain 'process control' of machines.

Computer Assisted Drafting TIA 1

General Objective:

Upon Completion of this activity, the student will be able to use a Computer Assisted Drafting Program to create simple drawings and save them to a computer storage device.

Specific Objectives:

Students will successfully complete the following objectives within a two an one half hour time limit. Success will be measured by the presence of a CAD file created by the student and saved on computer floppy disk.

1. Load the CAD program into the computer
2. Run the CAD program.
3. Use the drawing elements line, box, circle, polygon, and text to create a series of drawings on the computer.
4. Edit the drawing elements using the editing tools move, rotate, copy, erase, and undo.
5. Combine the drawing elements line box, circle, polygon and text to create a simple composite drawing.
6. Save the completed drawing to floppy disk.

Computer Assisted Drafting TLA 2.

General Objective:

Upon completion of this activity the student will be able to: (a) create, edit, and plot composite CAD designs; and (b) list drawing elements, list editing tools, and describe composite drawings.

Specific Objectives:

Given the equipment and material listed below, the student will complete the following objectives in an eight hour time limit.

1. Use the drawing elements Arc, and Curve.
2. Use the edit tools Stretch, Group, Ungroup, Break, Zoom.
3. Change the settings for Grid, Line Type, Snap, and Text.
4. Use the drawing assist features Ortho, Frame, Grid, and Snap.
5. Use the measure tools Distance and Align Dimension.
6. Create a composite drawing using the skills learned in TLA 1 and in this activity.
7. Save the Drawing.
8. Plot the drawing.
9. List 5 drawing tools used by a CAD program.
10. List 6 editing tools used by a CAD program.

11. Explain 'composite drawing'.

Robotics TLA 1

General Objective:

The student will gain practical experience with computer process control of machines by operating a programmable pedestrian light.

Specific Objectives:

Given the equipment and instructional materials listed below, the students will achieve the following objectives within a one hour time limit;

1. Connect the fischertechnik traffic light to the interface.
2. Connect the power supply to the interface.
3. Connect the interface to the computer.
4. Turn on the computer, load MS-DOS, load GWBASIC, load and run the Basic program PEDCROSS.
5. Program the 'on' time for the yellow and for the red traffic lights.
6. Operate the pedestrian light by executing the program and by pressing the pedestrian switch.

Robotics TLA 2

General Objective:

Students will program and operate a rectilinear robot system.

Specific Objectives:

Given the equipment and supplies listed below, the students will successfully perform the following operations within a one hour time limit.

1. Connect the plotter to the computer.
2. Set up plotter
3. Turn on all equipment.
4. Load MS-DOS, and GWBASIC.
5. Load and Run the program "Roland".
6. Remove the plotter output from the plotter and place new paper in plotter.
7. Modify some of the program statements and save the new program.
8. Run the program a second time and identify the differences in plotter output by answering the questions on the TLA.

Robotics TLA 3

General Objective:

The student will gain an understanding of the basic principles of robotics devices and obtain practical experience in operating a cylindrical coordinate robotic device.

Specific Objectives:

Given the equipment and instructional materials listed below, the students will perform the following activities within a two and one half hour time limit:

1. Program the fischertechnik robot to perform 'Pick and Place' operations.
2. Debug (fix problems in) the execution of the robot program.
3. Execute the robot program and have the robot successfully perform the operations.
4. Demonstrate an understanding of the process by answering the questions on the TLA.
5. View the videotape Fundamentals of Industrial Robotics.
6. List the 4 main parts of a robot.
7. List the 3 methods of classifying robots.
8. Give two examples of each classification method for robots.
9. List three methods of programming robots.

10. List the four limiting factors of robots.

Desktop Publishing TIA 1

General Objective:

Upon completion of this activity, the student will successfully create and print a simple page layout using a desktop publishing program.

Specific Objectives:

The student will successfully complete this activity within a two hour time limit by accomplishing the following objectives:

1. Load the program PageSetter into the Amiga computer.
2. Set the default parameters for page creation.
3. Set the default parameters for box creation.
4. Set the default parameters for the desktop environment or artboard.
5. Open the Text Editor.
6. Type in a short document.
7. Exit the Text Editor.
8. Create a page.
9. Place text on the page.
10. Save the page.
11. Print the page.

Desktop Publishing TLA 2

General Objective:

Students will use a desktop publishing package to create page layouts using text files and graphics files.

Specific Objectives:

Each student will perform the following within a two hour time period

1. Load a previously created PageSetter project file.
2. Resize the existing text boxes.
3. Unlink the existing text boxes.
4. Create new text boxes.
5. Link all text boxes in the correct sequence.
6. Add titles using QuickText boxes.
7. Create graphic boxes.
8. Open the Graphic Editor.
9. Load a graphic image.
10. Clip the image.
11. Exit the Graphic Editor.
12. Paste the image into the graphic box.
13. Save new project file, print page and exit using procedure learned in TLA 1.
14. State the basic function of a desktop publishing program.
15. State the two basic types of information)

manipulated by a desktop publishing program.

16. State the two types of programs used to provide information to desktop publishing programs.

17. List 5 tools used by desktop publishing programs.

DESIGN

Chapter 4

Designing the CourseCriterion Referenced Testing

Criterion Referenced Tests (CRTs) were developed to determine the level of student achievement, based on the standards set by the instructional objectives. These CRTs are based on competency or mastery learning.

The CRT for "An Overview of Technology" consisted of a paper and pencil test. This test was administered before the instruction (pretest) and again immediately after the instruction (post-test).

The CRTs for each of the three technologies had two components. The first CRT component was single paper and pencil test administered as a pretest and as a post-test. The second CRT component of each technology was performance based under natural conditions; each learner was required to successfully complete a series of tasks for each Technology Learning Activity.

Specific CRT requirements for each technology were:

1. Computer Assisted Drafting;
 - a. single paper and pencil CRT
 - b. a performance based CRT for each of two

TLAS

2. Robotics;
 - a. single paper and pencil CRT
 - b. a performance based CRT for each of three TLAs
3. Desktop Publishing;
 - a. single paper and pencil CRT
 - b. a performance based CRT for each of two TLAs.

The paper and pencil CRTs are contained in Appendix B, while the performance CRTs are outlined in the TLAs in Appendix E.

Media Selection

This course was divided into two logical components. The first was "An Overview of Technology", and the second was the TLAs. Each presented different problems for selection of appropriate media to be used in the delivery of the instruction. Each was analyzed separately for appropriate media selection. Each was subjected to similar restraints. The first restraint was the time available for the development of materials. Some of the equipment that the instruction was being written for was not available until six weeks before the course was to be taught, and the remainder did not arrive until three weeks before the class began. The

second restraint was that all materials had to be easily duplicated.

Media attributes. Media attributes considered essential for An Overview of Technology were: (i) three dimensionality, or the availability of the equipment from the particular technologies discussed, (ii) teacher controlled pacing, or the ability of the teacher to speed up some parts, or slow down others depending on the abilities of the students, (iii) random access of information, (iv) visual sensory mode, since a lot of verbal information was to be presented (augmented with visual aids), and (v) the ability to substitute different examples of technology and technological systems in order to relate the instruction to the experiences of the students.

Media attributes considered essential for the TLAs were: (i) self pacing of instruction, (ii) random access of information, (iii) combinations of sign types, or use of verbal and non-verbal symbols (text and diagrams), (iv) a visual sensory mode, and (v) individual use of the instructional materials.

Media Selection Decisions

The need for teacher controlled pacing and the need to demonstrate, or even substitute, the equipment from particular technologies indicated that An Overview of

Technology should consist of lectures, combined with the use of visual aids and demonstrations using the particular technological equipment. Media selected to meet these requirements were a teachers' manual complete with lecture notes, and transparency masters.

The TLAs needed to contain individualized, self paced instruction. The need to provide a large amount of randomly accessible instruction that is easily reproduced, and that the learner could use individually to perform operations on specific technological devices, restricted the media selection to print. Print allowed the learner to review a process, and check the steps as they were completed. Print also allowed easy access to diagrams and pictures of the steps that needed to be performed. Media selected as the primary source of instruction to meet the requirements of the TLAs was print.

DEVELOP

Chapter 5

Developing The Course

Developing the course involved three distinct stages. First, a search was made for existing instructional materials. Second, where they did not already exist, materials were developed. Third, after all instructional materials were obtained or developed they were evaluated.

The Search for Existing Materials.

During the initial stages of this project, a number of technology programs from across North America were reviewed. Information was obtained from a survey of Canadian provincial departments of education conducted by the author one year ago. Additionally, more recent information was obtained from a search of the ERIC data base using the following descriptors: Technology education, computer assisted drafting, robotics, desktop publishing, and information communications technology. Three of the major sources of information were the professional journals, The Technology Teacher, School Shop, and Industrial Education.

Discussions were held with more than a dozen educators from several states and provinces at the

International Technology Education Association
Conference held in Norfolk, Virginia in March 1988.
These discussions were aimed at discovering
instructional materials for this project. Discussions
with Dr. Preitz, University of Alberta, and Kendall N.
Starkweather, Editor-in-Chief of The Technology Teacher,
were particularly illuminating. The conference also
afforded an opportunity to review equipment and
instructional materials on display from commercial
sources as well as academic sources. Particular
attention was made of the materials available from
Delmar Publishers, Inc., and Davis Publications, Inc.,
two of the major publishers of technology textbooks and
teaching materials. Discussions with the
representatives from these two companies resulted in the
acquisition of several relevant textbook series. These
texts were major sources of information for developing
instruction.

A letter was sent to all the advertisers in School
Shop, Industrial Education, and The Technology Educator
that were in any way associated with general industrial
technology education, or that were associated with CAD,
robotics, or desktop publishing. About 50 percent of
the advertisers responded with descriptions and/or
samples of the materials they supply.

During this four month period, several discussions

were held with the client, and he was able to recommend one source of instructional materials that was later used. The robotics videotape that was obtained from this source was the only outside source of instruction that were used.

A large body of excellent instructional material was discovered as a result of this broad review. There were, however, problems with just about all these programs and materials. First, they were designed to be delivered over a much longer time period than was available to this project. Programs tended to cover junior high, high school, and college. This program needed to compress the concepts from much longer and more comprehensive courses into a thirty hour course for first time use by college students.

A second reason for not selecting any of the course material was the nature of the technological equipment required to deliver the instruction. Although the information could be applied to almost any example of the technology, activities were written for specific equipment. Much of the equipment specified was too expensive and too large for this project. Most courses specified industrial equipment. Those that did not were directed at a younger learner.

A third reason was the poor fit of the materials to the objectives for this course. Almost all the

materials met some of the objectives, none met all the objectives. There was one previously mentioned exception - a videotaped instructional package was discovered which met the objectives for the information content of the robotics technology component.

The decision was made to adopt this videotape as the main source of instruction for robotics technology information. This instruction met the requirements of the paper and pencil CRT for robotics. As this videotape was the only existing instructional material that met the criteria for adoption, all other instructional materials were developed.

Initial Development of Materials

Discussions were held with the client to schedule time allocations for the course components. Three hours were scheduled for teaching An Overview of Technology and one hour was scheduled to outline technologies used by the TLAs. Times allocated for students to complete the TLAs were: (i) five hours for desktop publishing TLAs, (ii) five hours for robotics TLAs, and (iii) sixteen hours for CAD TLAs.

Hardware and software selections were made and further discussions were held with the client to confirm those selections. Following those discussions, hardware and software specifications were completed and equipment

and software were ordered.

AutoSketch Enhanced (a student version of AutoCad) was selected as the computer assisted drafting program for use in CAD TLAs. This choice was based on the following: (i) the close match between the program's features and the CAD TLA objectives, (ii) the simple, introductory nature of the program, and (iii) the low cost of the program (less than 1/20th of the cost of the professional version of the same program).

There were two options for robotics: (i) use industrial style robots, and (ii) use fully functional models of industrial equipment. Because of cost and space limitations, model equipment was chosen. A number of systems were available. Fischertechnik robotics equipment was chosen for the following reasons: (i) it could be configured as a number of different robotics systems, (ii) it could be used to meet the objectives of current and future robotics TLAs, (iii) it was easy to assemble and use, (iv) software drivers (operating programs) came with the equipment, (v) the equipment is part of a large variety of components and can be enhanced in a number of ways, and (vi) it was moderately inexpensive.

PageSetter was selected as the desktop publishing program for use in the DTP TLAs. Reasons for this choice were: (i) it met the objectives of the TLAs more

closely than the other programs available, (ii) it was the least complicated program to work with and provided the shortest 'learning curve', and (iii) it was inexpensive.

Five workstations were assigned: Three for CAD, one for Robotics, and one for Desktop publishing. These specifications were established for workstations: (i) for a CAD workstation - MS-DOS compatible computer with 640k RAM, parallel port, 20 Megabyte Harddisk, math coprocessor, mouse, Hercules monochrome graphics, and a Roland DXY980 plotter, (ii) for a robotics workstation - MS-DOS computer with at least one floppy drive, 256k RAM, monochrome monitor, a parallel port, and GWBasic, and (iii) for a desktop publishing workstation - an Amiga 500 or 2000 computer with a dot matrix printer and an RGB analog monitor.

As the hardware and software arrived, the TLAs were written. Each piece of instruction was based on the objectives for that TLA, and was fine tuned to be used with the particular equipment. TLAs include concept and task analysis diagrams as well as statements of objectives. The TLA instructions provided the performance activities for the students. Evaluation of a performance CRT was based on student performance on a TLA.

The Desktop publishing TLAs were written first.

The overall goal of this set of TLAs was to have the student use the computer system to design and produce a paper copy of a page layout which contained text and graphics.

The desktop publishing TLAs were designed to provide the student with three types of information. This information was not labeled by category during any of the testing stages of this project. Due to problems that students encountered in distinguishing the three types of information during validation (final) testing, three headings were later added at appropriate places throughout the TLAs. The first type of information has been labeled Information: Please Read. Information provided under this heading describes a process or procedure or provides background information essential to understanding the process/procedure. The second type has been labeled Do This, and consists of the performance instructions for the TLA. The third type has been labeled This will Happen, and provides the student with information concerning what to expect after executing the performance instructions. The information contained under these three headings was not reorganized or altered in any other way.

Robotics TLAs were organized into 4 sections: (i) information concerning robotics operations and procedures, (ii) setting up the equipment, (iii)

operating the equipment, and (iv) Appendices. Instructions for operating the equipment were interspersed with questions to which the learner was required to respond. This was designed to reinforce the student's understanding of the processes. The TLA Appendices contain assembly diagrams for the equipment, wiring diagrams for the equipment, and program listings for the GWBASIC programs used to operate the equipment.

Both CAD TLAs were designed to introduce a number of drawing and editing features. As each drawing feature was introduced: (i) information was provided outlining the purpose and method of operation of that feature, and (ii) sample problems were provided for student practice. The final exercise for each activity required each student to construct a drawing typical of the type used at that level of manual drafting. The second TLA was designed to have the student produce a paper copy of the drawing on a pen plotter.

Formative Evaluation - Expert Appraisals

As the materials were developed, they were evaluated by battery of experts, and some of the materials were tested by a representative group of learners.

The Experts.

Appraisal of instructional materials was conducted with the aid of a content expert, a media expert, and the client. The content expert also doubled as a learning strategies expert.

Content expert. The content expert holds undergraduate degrees in Physics and in Education as well as a Diploma of Industrial Arts from Memorial University. He has a masters degree in Technology Education from the University of New Brunswick. He taught Industrial Arts for 16 years, has taught the summer industrial arts program at Memorial University for several years, and is currently Coordinator of Science and Technology with the Avalon North Integrated School Board.

Media expert. The media expert is an assistant professor, Division of Learning Resources, Memorial University. He received his Ed.D. in the Division of Instructional Systems Technology at Indiana University, where he was the recipient of an EPDA Pett-Fleming Fellowship. He taught graduate courses, supervised an instructional development unit, and instructed production courses at Indiana University.

His teaching experiences include junior and senior high. He also served as graphic arts consultant for the school system on the island of Guam, in the western

Pacific.

Client. The client is the Department Head for Special Programs, Memorial University. He has been coordinator of the Industrial Arts Diploma Program for the past eight years. He earned a B.A. in Industrial Arts and an M.Voc.Ed. from the University of Alberta, and a Ph.D. from Texas A. and M. He has taught Industrial arts at the public school and university levels for the past 21 years.

Expert Appraisals.

Content appraisal. Formal Content Appraisal was done using Checklist One and Checklist Two (Appendix C). In addition, the content expert was involved in a number of discussions concerning objectives and content during all stages of development of this project. He was present for much of the pilot testing and for most of the validation testing, and was in fact co-teacher of the technology education course which used these instructional materials:

The content appraisal was conducted on the concept and task analysis, instructional objectives, the instructors manual for Introduction to Technology, and on the Technology Learning Activities.

Evaluation Checklist One: Appropriateness of Instructional Content. This checklist had six items and

used a five point scale ranging from "unacceptable" to "outstanding quality" for each item. The content expert chose "outstanding quality" for appropriateness of concepts, sequencing of concepts, and theoretical soundness of objectives. He chose "better than average" for completeness of concepts and wrote this comment: "time would not permit a more complete treatment". He also chose "better than average" for relevance of objectives to the general goals and for stated rationale of the objectives.

Evaluation Checklist Two: Content. This checklist had seven items, each with a three point scale ranging from "poor usability" to "good usability". Responses to six items were "good usability", and several had the comment 'excellent' added. One item, difficulty level, was marked "average usability".

There was a suggestion made to use more diagrams in specific locations in the TLAs. A separate section was requested to teach wordprocessing and graphics before teaching desktop publishing. A number of minor but very helpful suggestions were made concerning the visual appearance of the materials.

Decisions Concerning Suggestions. With the exception of additional TLAs on wordprocessing and graphics, most all of these suggestions have been incorporated into the final edition. Although

additional TLAs on wordprocessing and computer graphics were highly desirable, and were initially considered necessary, the time allocated to the course prevents this option.

The content experts final comment was "this is the best piece of instruction that I have seen for technology education".

Media appraisal. Media appraisal was done using evaluation Checklist Three, Quality of Materials, and Checklist Four, Feasibility of Materials.

The Quality of Materials list responses allowed a three point choice between ten pairs of opposite adjectives. Responses for seven pairs were positive, and for three pairs they were on the midpoint of the scale. The material was judged to be useful, effective, clear, relevant, appropriate, efficient, and valuable.

Comments. The client included the following comments: (i) Objectives are very clear; (ii) material is well ordered; (iii) the scope may intimidate the learner, unless it is administered in small doses; combined with hands on manipulation of the various "toys" this should be a dynamic package; and (iv) the learner will not be an expert but should have a sound understanding of the basic principles.

Decisions on comments. No action was taken because

the materials are designed to be administered one activity at a time, and the program was designed as a hands-on entry level program so that expertise was not expected.

The six items in the Feasibility of Materials checklist were rated on a three point scale ranging from "poor usability" to "good usability". Preparation time for use and instruction manuals were rated at "good usability". All others were rated at "average usability".

Comments. Comments included the following: (i) The materials are well organized and instructions and details are complete enough for easy implementation, (ii) One of the important considerations for this type of program is that the required equipment be available and work properly every time so that students do not have to wait.

Client appraisal. The Client appraised the concept analyses, task analyses, instructors manual, and instructional materials using Evaluation Checklist Five. Responses to the six items were on a five point scale from "unacceptable" to "outstanding quality". Of the six items, the first one ("material is worth implementing") and the last four ("material fits teaching methods", "project is valuable to you", "fits

the curriculum", and "appropriate time available") were rated "outstanding". The second one ("material is in a usable form") was rated "better than average". That was to be expected since the materials were printed in draft mode on a dot matrix printer and had not been produced in final quality at the time of evaluation.

The client viewed the instructional materials at various times during the design stage, but evaluation was done at the time of validation testing.

The client commented that the material provides an excellent introduction to technology in industrial education.

Formative Evaluation - Developmental Testing.

Developmental testing was conducted on the instructional materials to measure and subsequently improve their effectiveness and validity. The normal course of events would have been to proceed in three stages: First, test the materials in a face-to-face situation with the learners and revise on the spot; second, quantitatively test the 'final' version and make the necessary modifications; and third, test the materials under actual conditions. This instruction was for a thirty hour course, and much of the equipment for the courses did not arrive on time. It was, therefore,

not practical to evaluate all the instructional materials and proceed through the three stages. For these reasons, developmental testing consisted of face-to-face evaluation using these representative samples of the instruction:

CAD TLA 1

Robotics TLA 3

DTP TLA 1.

In addition to on-the-spot changes, notes were made of the learners problems, and the learners wrote comments and problems on the instructional materials. These were incorporated into revisions and interpolated across the other pieces of instruction.

Setting. Testing for CAD and DTP was conducted at the Avalon North Integrated School Board offices and testing for Robotics, was conducted at one of the schools for that board.

Group. Subjects were industrial arts teachers. None had prior experience with these technologies. Each activity was tested with a group of two. It was assumed that these learners were representative of the target group.

Procedure. Testing was conducted in an informal setting. A short lecture was given outlining the concept analysis for An Overview of Technology, as well as the concept analysis for the area of instruction

relevant to the test.

The subjects were then given the instructional materials and the equipment. They were asked to work through the activities, making notes of any problem areas.

General Observations. The test subjects were generally enthusiastic about the activities, which were all completed under the time limits. The observations that were made and problems that were reported during the test are outlined below.

Results: Computer Assisted Drafting. No major problems were observed. Several incidents of omission of one or two words from the instruction sequence were reported.

Results: Desktop Publishing. A number of small problems were observed. These were mostly related to inadequate instruction on the use of the menu and mouse system used by the computer. These problems were also identified and reported by the subjects as they occurred.

Results: Robotics. Three problems were observed and were also reported by the subjects. First, the equipment was unfamiliar and was unlabeled. This created some confusion when assembling the devices. Second, instructions for getting the program operating were not simple enough and assumed competencies not

present. Third, instructions were spaced too closely on the page, causing some difficulty for the learner to keep track of his 'place'.

After the materials were tested and revised, all TLAs and An Overview of Technology were produced for summative evaluation.

DISSEMINATION

Chapter 6

Summative Evaluation

Dissemination of instructional materials normally involves validation - or summative evaluation, final packaging, and distribution of the materials. In this case, the evaluation served as validation testing for most of the materials. The instructional materials (TLAs) for Desktop Publishing were found to need revisions. The proper course of events would be to revise the materials and perform validation testing again. The next class that will be available for re-testing will be one year from now, rendering testing impractical. The revisions to Desktop Publishing TLAs were made as described below (the revisions were also noted earlier), with the assumption that further testing would validate the revisions.

Validation Testing

Setting. Testing took place in the Industrial Education laboratory at Memorial University. Five, two person, computer workstations were established. Two were fully equipped CAD stations, one was set for robotics, and one was set for Desktop Publishing. The fifth was a partially equipped CAD station. It did not

have a math coprocessor, and operated the program at 20 percent of the speed of the other CAD stations. In addition, program operation was by the keyboard and was much slower than the normal method of using a mouse. It was used for those times in the schedule when a third CAD station was needed.

Group. The group consisted of eight, third year Diploma of Industrial Education students. There were four groups of two students. Groups were labeled A, B, C, and D for scheduling purposes.

Procedure. Students were given the paper and pencil CRT pretest (Appendix B) on technological concepts covered in An Overview of Technology. Students were grouped at the front of the laboratory for the three hour An Overview of Technology and were then given the same CRT as a post-test.

Following the post-test on An Overview of Technology, students were given a written CRT pretest (Appendix B) for each of three specific technologies: (1) CAD, (2) Robotics, and (3) Desktop Publishing. In addition, each was asked if he had used any of these technologies previously. An hour was then spent teaching the conceptual framework of the three technologies and how each technology related to the general conceptual framework of the overview.

Part Two of the course required each two person

team to complete two CAD TLAs, three Robotics TLAs, and two Desktop Publishing TLAs. Each TLA presented information and required the students to follow instructions to operate equipment and produce an output. The outputs from the TLAs were the practical components of the CRTs.

Outputs from each Technology Learning Activity are listed below:

CAD TLA 1	output: create, save drawing
CAD TLA 2	output: create, save, plot drawing
Robotics TLA 1	output: operate closed loop process controller
Robotics TLA 2	output: program rectilinear coordinate robot to produce a plot
Robotics TLA 3	output: program cylindrical coordinate robot to perform pick and place operations
Desktop Pub. TLA 1	output: create, print simple page layout.
Desktop Pub. TLA 2	output: create, print, text/graphic page layout

Groups worked through the activities according to the schedule shown in Appendix D. Each activity was run once for each group for a total of four times.

General Reaction. Students scored well on the post test for the introduction to technology. In the activity section, each group succeeded in completing each activity on time. CAD TLAs worked very well for most groups. One group had some difficulty completing the drawing for the CAD TLA 2. A little investigation revealed that the two students had gone through the lead-in exercises without completing them.

The Robotics TLAs worked very smoothly after several minor problems were corrected with the robotics equipment.

All groups had some difficulty with Desktop Publishing TLA 2. There appeared to be two factors at work here. First, the computer program was more complex than any of the others being used in the course. Second, there was some confusion in the instructions. The learners were having difficulty separating the 'information' from the 'do this' and the 'this will happen' components of the instruction.

Following completion of all TLAs, students were post-tested with the paper and pencil CRTs for each technology (Appendix B).

Test Results: An Overview of Technology. Pre and Post-test results for An Overview of Technology are shown in Table 1. Pretest scores ranged from 0 (0%) to 1 (12%), with an average of 0.25 (3%). Post test scores

Table 1 Pre-Post Test Scores for An Overview of
Technology

Table 1 Pretest/Post-Test Results for An Overview of Technology

	Student								
	1	2	3	4	5	6	7	8	mean
<hr/>									
Pretest									
n	0	0	1	0	0	0	0	1	0.25
%	0	0	12.5	0	0	0	0	12.5	0.03
Post-Test									
n	6.75	6	7.75	8	6	7	8	8	7.2
%	84	75	96.8	100	75	87.5	100	100	90.1

Total Possible Test Score: 8

ranged from 6 (75%) to 8 (100%) with an average of 7.2 (90%). There was an average gain of 6.96 (87%) for this introductory section of the course.

CAD Results. All paper and pencil pretest (Appendix B) scores for CAD were zero. None of the students had previous experience with CAD, and none were able to produce and plot the drawing. Scores on the same CRTs given as post-tests ranged from 12 (85.7%) to 14 (100%) and had mean of 13.75 (98.2%) out of 14. There was an average gain of 13.75 (98.2%).

All students successfully completed the two performance TLAs. The evaluation of performance CRTs was based on each student's output from each TLA. Output quality was judged by the author on the basis of completeness of detail, accuracy, and overall appearance. The mean for the performance CRT for CAD TLA 1 was 100%, and for CAD TLA 2 was 91.3%. The results of all CAD evaluations are shown in Table 2.

Robotics Results. Pretest (Appendix B) scores ranged from 0 (0%) to 1 (6%) with a mean of 0.125 (0.7%). Post-test scores ranged from 10 (59%) to 17 (100%) with a mean of 13.85 (81.4%) out of 17. There was an average gain of 13.71 (80.7%). The results are shown in Table 3.

All students successfully completed the performance CRTs. The evaluation of performance CRTs were based on

Table 2 Computer Assisted Drafting Results

Table 2 Computer Assisted Drafting Results

	Student								
	1	2	3	4	5	6	7	8	Mean
Pretest									
n	0	0	0	0	0	0	0	0	0
%	0	0	0	0	0	0	0	0	0
Post-Test									
n	14	12	14	14	14	14	14	14	13.63
%	100	85.7	100	100	100	100	100	100	98.2
TLA 1									
n	100	100	100	100	100	100	100	100	100
%	100	100	100	100	100	100	100	100	100
TLA 2									
n	90	90	90	90	95	95	90	90	91.3
%	90	90	90	90	95	95	90	90	91.3

Total possible test score: 14

Total possible TLA score: 100

Table 3 Robotics Results

Table 3 Robotics Results

	Student								
	1	2	3	4	5	6	7	8	Mean
Pretest									
n	0	0	0	0	0	1	0	0	0.13
%	0	0	0	0	0	5.9	0	0	0.01
Post-Test									
n	14	14	14	13	12	10	17	15	13.6
%	82.3	82.3	82.3	76.4	70.6	58.8	100	88.2	80.1
TLA 1									
n	100	100	100	100	90	90	100	100	97.5
%	100	100	100	100	90	90	100	100	97.5
TLA 2									
n	93	93	96	96	93	93	93	93	93.7
%	93	93	96	96	93	93	93	93	93.7
TLA 3									
n	83	83	84	84	97	97	100	100	91.0
%	83	83	84	84	97	97	100	100	91.0

Total possible test score: 17

Total possible TLA score: 100

observation of performance and on evaluation of written output. Students were observed for the final performance of each activity. Successful completion of the activity was awarded full marks. Written work consisted of answers to questions throughout the robotics TLAs. Answers were judged on the basis of merit, since in many cases there was more than one correct answer. The mean performance score for robotics TLA 1 was 97.5 percent, for robotics TLA 2 was 93.8 percent, and for robotics TLA 3 was 91 percent.

Desktop Publishing Results. Desktop publishing pretest (Appendix B) scores ranged from 0 (0%) to 4 (40%) with a mean of 0.75 (7.5%). Only the student scoring 40 percent had previous experience with desktop publishing. Post-test scores on the same CRTs ranged from 0 (0%) to 10 (100%) with a mean of 5.06 (50.6%). There was an average gain of 4.31 (43.3%) out of 10 (Table 4).

Two students scored very low on the desktop publishing paper and pencil post-test. The student scoring zero scored 100 on all other paper and pencil post-tests, and successfully completed all activities for all technologies. The person scoring 20 had a 92 average on the other paper and pencil post-tests, and successfully completed all activities.

A follow-up discussion with the two students

Table 4 Desktop Publishing Results

Table 4 Desktop Publishing Results

	Student								Mean
	1	2	3	4	5	6	7	8	
Pretest									
n	0	0	0	1	1	4	0	0	0.75
%	0	0	0	10	10	40	0	0	7.5
Post-Test									
n	6	8	2	6	7	10	0	7.5	5.8
%	60	80	20	60	70	100	0	75	58.1
TLA 1									
n	100	100	100	100	100	100	100	100	100
%	100	100	100	100	100	100	100	100	100
TLA 2									
n	95	95	90	90	95	95	90	90	92.5
%	95	95	90	90	95	95	90	90	92.5

Total possible test score: 10

Total possible TLA score: 100

revealed that although both were in different groups, and both performed the activities at different times, both were absent from the lab during the most of the second desktop publishing TLA. As a result of lost time, both misinterpreted the basic desktop publishing concept of a 'desktop environment', and therefore the answers to most, or all, the questions on the test. A brief discussion clarified the concept and it appeared from the remainder of the discussion that both students would have no problems completing the test at that time.

If these two students were discounted, the mean post-test score would be 7.42 (74.2%) for an average gain of 6.67 (66.7%).

All students successfully completed the performance CRTs. Performance CRTs were based on the successful creation and printing of the page layout in each TLA. The output was judged on accuracy of placement of items and correct data entry where data entry was required. The performance results for TLA 1 showed a mean of 100 percent and for TLA 2 showed a mean of 97.5.

Experience survey. Student responses on an evaluation experience questionnaire (Evaluation Checklist Six, Appendix C) given after the post-tests showed a very favorable reaction to the course. The modified Likert scale required students to choose between two opposite descriptors. Except for two

students choosing unclear on the clear/unclear pair, all students choose the positive descriptor for all pairs. There was a 98 percent positive response.

Summary. Despite the sheer volume and scope of this project, the test results were very positive. Students were very actively involved in the TLAs and developed very positive attitudes towards cybernetics-technology. This was in marked contrast to some of the negative attitudes and fears expressed by several students at the beginning of the session. Although this initial reaction was not anticipated, it probably should have been; it may have been more reasonable to anticipate that the learners would have some fear of unknown technologies.

Chapter 7

Results, Implications, and Recommendations

Results

The introduction to technology course produced by this exercise for the Diploma of Industrial Arts Program at Memorial University showed an overall gain score by the students of 83.2 percent (discounting the two students in DTP). There was a combined performance mean of 95.9 percent. The combined mean for all paper and pencil post-tests and all performance CRTs was 90 percent. Despite problems with several components, these results indicate a high degree of success.

The client has indicated that the course has been adopted as a regular component of the university's industrial arts program, and it will be taught to the level three students during each summer's session.

Implications

Research for this project indicates that the traditional industrial arts program cannot deliver the learning experiences needed to provide citizens with a degree of technological literacy in a post-industrial technological society. Programs need to be organized around technological systems rather than around

materials and processes.

This implies a radical change for the Newfoundland program in terms of curriculum organization, program content, delivery methodology, and facilities.

Recommendations

Recommendation one: The University should undertake a program of research and development to change the existing industrial arts program into a technology education program.

Recommendation two: The university should develop an undergraduate degree program in technology education.

Recommendation three: The provincial Department of Education should develop a comprehensive technology education program which addresses the technological literacy needs of elementary and secondary students.

Recommendation four: The Industrial Arts Special Interest Council through its parent body, the Newfoundland Teachers Association, should pursue a policy of increasing administrators' and teachers' awareness of the value of technology education.

Recommendation five: The Industrial Arts Special Interest Council should develop program guidelines for the development of a technology education program.

References

- Abram, R., Ashley, W., Faddis, C., & Wiant, A. (Eds.). (1982). Programs that work. In Preparing for High Technology, The National Center for Research in Vocational Education. Columbus, Ohio: Ohio State University.
- Abram, R., Ashley, W., Höfmann, R., & Thompson, J. (Eds.). (1983). CAD/CAM programs. In Preparing for High Technology, The National Center for Research in Vocational Education. Columbus, Ohio: Ohio State University.
- Abram, R., Ashley, W., Konopka, E., & Carrico, L. (Eds.). (1983). Robotics programs. In Preparing for High Technology, The National Center for Research in Vocational Education. Columbus, Ohio: Ohio State University.
- Abram, R., Ashley, W., Rose, B. & Landrum, B. (Eds.). (1983). 30 steps to implementation. In Preparing for High Technology, The National Center for Research in Vocational Education. Columbus, Ohio: Ohio State University.
- American Council of Industrial Arts Supervisors. (1987). Learning activity packets: Robotic technology. Reprinted with permission from Utah State Office for Vocational Education.
- Andrews, G. (1987). Identification of Parameters of Technology Education for Newfoundland Schools. Unpublished master's thesis, University of New Brunswick.
- Balistreri, J. P. (1987). What we know about change. Technology Teacher, Feb., 3-5.
- Bame, E. A. (1986). Middle/Junior high technology education. In R. E. Jones & J. R. Wright (Eds.), Implementing technology education (pp. 70-94). 35th. Yearbook, American Council on Industrial Arts Teacher Education.
- Barnes, J. L. (1988). Examining technology curricula in countries around the world. School Shop: International Perspectives on Technology Education, April, 50-51.

- Bennett, C. A. (1937). History of manual and industrial education 1870 to 1917. Peoria: Chas. A. Bennett Co. Inc.
- Bensen, M. J. (1988). Challenges and prospects at the international level. School Shop: International Perspectives on Technology Education, April, 46-49.
- Bertoline, G. (1988). Fundamentals of CAD, 2nd Ed. New York: Delmar Publishers Inc.
- Boyer, E. L. (1985). A perspective on education. Technology Education: A Perspective on Implementation. ITEA, 3-6.
- Campbell, M. B. (1988). Comparing IA/ET programs in Western European nations. School Shop: International Perspectives on Technology Education, April, 20-22.
- Carter, L. & Culberson, G. (1988). Craft, design, and technology in the United Kingdom. School Shop: International Perspectives on Technology Education, April, 28-29.
- Crocker, R. and Riggs, F. (1979). Improving the Quality of Education Challenge and Opportunity [Task Force Report]. St John's: Department of Education.
- Cummings, P. C. (1987). Technology programs, Norfolk, Virginia. The Technology Teacher, March: 15-17.
- Daiber, R. A. & LaClair, T. D. (1986). High school technology education. In R. E. Jones & J. R. Wright (Eds.), Implementing technology education (pp. 95-137). 35th. Yearbook, American Council on Industrial Arts Teacher Education.
- Deforge, F. (Ed.). (1972). The teaching of technology. (A report prepared for the Council of Europe for Cultural Cooperation Committee for General and Technical Education). Strasbourg, France: Council of Europe.
- Technology 100. (1987). Department of Education. Program Development and Implementation. Fredrickton, New Brunswick.

- DeVore, P. W. (1987). Technology and science. In E. N. Isreal & T. R. Wright (Eds.), Conducting Technical research (pp. 27-45). 36th. Yearbook, Council on Technology Education. Mission Hills, Ca.: Glenco Publishing Co.
- Dixon, K. (1986). The vocational aspect of education. Vocational Aspect of Education. 38 (100), 33-34.
- Dugger, W. E., Barme, E. A., and Pinder, C. A. (1985). Standards for Technology Education Programs Project. The Goodhart-Willcox Company, Inc., for The American Industrial Arts Association.
- Dunsmore, T., & Dixon, M. (1987). Integrated electronics and the community college. Industrial Education, May: 14-15.
- Erber, E. E. (1969). Industrial technology: Implications for industrial and technical teacher education. In C. T. Dean & N. A. Hauer (Eds.), Industrial Technology Education, 18th. Yearbook, American Council on Industrial Arts Teacher Education (pp. 41-69). Bloomington, Ill.: McKnight & McKnight Publishing Co.
- Faddis, C., Ashley, W., & Abram, R. (Eds.). (1982). Strategies for change. In Preparing for High Technology, The National Center for Research in Vocational Education. Columbus, Ohio: Ohio State University.
- Frye, R.M. (1987). Century Twenty-One has arrived. In Dr. M. Oaks (Ed.), Technology Education, Monograph One (pp. 2-4). Washington State University, for Washington Industrial Arts Association.
- Gerstenecker, D., Daiber, R., Moore, M., & Conley, R. (1987). Technology programs, Troy, Illinois. The Technology Teacher, April: 23-28.
- Goetsch, D. L. & Nelson, J. A. (1987). Technology and You. New York: Delmar Publishing Inc.
- Goetsch, D. L. (1988). Understanding high technology. The Technology Teacher, 45 (6), 29-31.
- Good, J. E. (1986). New York state curriculum plans. The Technology Teacher, February, 5-11.

- Glines, D. E. (1986). Technology education and the future. The Technology Teacher, 45 (4), 7-9.
- Glines, D. E. (1988). Perspective: Principals with vision. The Technology Teacher, 47 (4), 3-7.
- Hacker, M. & Barden, R. A. (1988). Living with Technology. Albany, N.Y.: Delmar Publishers.
- Hales, J. A. and Snyder, J. F. (Eds.), (1986). Jackson's model of industrial arts curriculum theory. Fairmount, Va.: Fairmount State College.
- Harrison, G. B. (1980). The role of technology in science education. In C. P. McFadden (Ed.), World Trends in Science Education (pp. 18-26). Halifax: Atlantic Institute of Education.
- Helsel, L. D. & Jones, R. E. (1986). Undergraduate technology based education: The technical sequence. In R. E. Jones & J. R. Wright (Eds.), Implementing technology education (pp. 171-200). 35th. Yearbook, American Council on Industrial Arts Teacher Education.
- Holloway, H. D. (1987). Developing high technology curriculums. Industrial Education, May, pp. 12-13.
- Industry and Technology Education. A guide for curriculum designers, implementors and teachers. A project funded by The Technical Foundation of America, Lansing, Ill.
- Iley, J. L. (1987). Technology programs, Pittsburg, Kansas. The Technology Teacher, February: 23-30.
- Johnson, J. R. (1985). The nature of our technological society. Technology Education: A Perspective on Implementation. ITEA, 11-14.
- Jones, R. E. (1986). A primer for technology education. Department of Visual Communication and Technology Education. College of Technology. Bowling Green State University, Ohio: Bowling Green.
- Kasprzyk, S. F. (1980). Technology: A socio-historic perspective. In Anderson, H. A. & Benson, M. J. (Eds.) Technology and Society: Interfaces with Industrial Arts. 29th Yearbook, American Council on Industrial Arts Teacher Education.

- Kuhn, S. T. (1970). The structure of scientific revolutions. London: University of Chicago Press.
- Lauda, D. P. & McCrory, D. L. (1986). A rationale for technology education. In R. E. Jones & J. R. Wright (Eds.), Implementing technology education (pp. 15-46). 35th. Yearbook, American Council on Industrial Arts Teacher Education.
- Listar, G. & Schiffman, P. (1986). Technology programs. The Technology Teacher, 46 (1), 15-18.
- Locatis, C. N. (1988). Perspective: Notes on the nature of technology education. The Technology Teacher, 47 (7), 3-6.
- Lux, D. G. (1979). The development of selected contemporary industrial arts programs: The industrial arts curriculum project. In Martin, G. E. (Ed.) Industrial Arts Education: Retrospect. Prospect. 28th Yearbook, American Council on Industrial Arts Teacher Education.
- Lux, D. G. (1981). Industrial arts redirected. In R. Barella & T. Wright (Eds.), An interpretive history of industrial arts: The interrelationship of society, education, and industrial arts (pp. 205-225). 30th. yearbook, American Council on Industrial Arts Teacher Education. Bloomington, Ill.: McKnight Publishing Co.
- Maley, D. (1960). Research and experimentation in the junior high schools. In The Unit Method, a monograph of the International Technology Education Association, Washington, D.C.
- Maley, D. (1982). Industrial arts puts the whole student in the school. In D. Maley & K. N. Starkweather (Eds.), The contributions of industrial arts to selected areas of education (pp. 247-266). 31st. Yearbook, American Council on Industrial Arts Teacher Education. Bloomington, Ill.: McKnight Publishing Co.
- Maley, D. (1987). Technology program: Integrating math and science into technology education. The Technology Teacher, May/June, 9-12.

- Maley, D. (1987). Perspective. Technology education, challenges and opportunities. The Technology Teacher, April, 3-6.
- Marshall, S. M. (1975). A survey of the attitudes of Newfoundland educators towards industrial arts. Unpublished master's thesis. State University College, Oswego, New York.
- Nee, J. G. (1988). The USSR's development of polytechnic education. School Shop: International Perspectives on Technology Education, April, 30-31.
- Nee, J. G. (1987). Reviewing the development of Soviet polytechnical education. Industrial Education, November, 30-36.
- Nelson, L. P. (1981). Background: The European influence. In R. Barella & T. Wright (Eds.), An interpretive history of industrial arts: The interrelationship of society, education, and industrial arts (pp. 19-48). 30th Yearbook, American Council on Industrial Arts Teacher Education. Bloomington, Ill.: McKnight Publishing Co.
- Peterson, R. E. (1986). Elementary school technology education programs. In R. E. Jones & J. R. Wright (Eds.), Implementing technology education (pp. 47-69). 35th Yearbook, American Council on Industrial Arts Teacher Education.
- Phillips, K. (1985). A progression of technology in industrial arts technology. Technology Education: A Perspective on Implementation. ITEA.
- Richards, H.E. (1987). Robotics in the technology education classroom. In Dr. M. Oaks (Ed.), Technology Education, Monograph One (pp. 62-67). Washington State University, for Washington Industrial Arts Association.
- Ristow, J.A. (1987). The origin of technology education. In Dr. M. Oaks (Ed.), Technology Education, Monograph One (pp. 18-22). Washington State University, for Washington Industrial Arts Association.
- Rudisill, A. E. (1987). Technology curricula: Chaos and conflict. Journal of Industrial Teacher Education, 24 (3), 7-17.

- Sanders, M. (1985). Transitioning quality industrial arts into technology education. The Technology Teacher, 45 (2), 27-28.
- Sharon, D.; Harstein, J. & Fischer, M. (1987). Part 1: Robotics literacy curriculum. Industrial Education, Feb., 44-46.
- Sharon, D.; Harstein, J. & Fischer, M. (1987). Part 2: Robotics literacy curriculum. Industrial Education, March, 18-21.
- Smith, D. F. (1981). Industrial arts founded. In R. Barella & T. Wright (Eds.), An interpretive history of industrial arts: The interrelationship of society, education, and industrial arts, 30th. yearbook (pp. 165-204). American council on industrial arts teacher education. Bloomington, Ill.: McKnight Publishing Co.
- Smith, K. L. (1987). Technology program, John Hanson Middle School, Charles County, Maryland. The Technology Teacher, 47 (2), 25-31.
- Smith, D. (1987). Determining entry level competencies. Industrial Education, March, 14-17.
- Sredl, H. R. (1988). Educating the Chinese people to further industrial goals. School Shop: International Perspectives on Technology Education, April, 39-40.
- Stashak, G. (1981). Technology literacy: The publisher's role. In R. E. Jones & J. R. Wright (Eds.), Implementing technology education. 35th. Yearbook, American Council on Industrial Arts Teacher Education.
- Stern, S. & Matsuda, T. (1988). Japan educates its students in technology and computers. School Shop: International Perspectives on Technology Education, April, 44-43.
- Sterry, L. (1987). A relationship between technology education and trade and industrial education. Technology Teacher, Feb., 11-14.
- Sutton, J. R. & Carter, L. (1986). Industrial technology education: Goal setting for success. ATEA Journal, Jan./Feb., 12-13.
- Swyt, D. A. (1986). Technology, industry, skills and education. The Technology Teacher, 45 (7), 5-9.

- Swyt, D. A. (1987). An agenda for progress in technology education: A personal view. The Technology Teacher, 47 (1), 3-8.
- Technology education: A direction for the profession. (1985). Technology Education: A Perspective of Implementation. ITEA, 25-28.
- The Technology Teacher. (1985). 45 (2), Cover.
- Thiagaragan, S., Semmel D. S. & Semmel, M. I. (1974). Instructional development for training teachers of exceptional children. Center for Innovation in Teaching the Handicapped. Bloomington, Indiana: Indiana University.
- Thode, B. (1985). The Wood River Industrial Technology Program. Wood River Junior High School, Halley, Idaho.
- Tobin, H. (1987). Technology programs, Chicago, Illinois. The Technology Teacher, 46 (4), 7-11.
- Todd, R. D. (1985). Technology education: An international perspective. Technology Education: A Perspective on Implementation. ITEA, 19-24.
- Warren, P.J. (1967). Report of the Royal Commission on Education and Youth, 1. St. John's: Dept. of Education.
- Waetjen, W. B. (1985). People and culture in our technological society. Technology Education: A Perspective on Implementation. ITEA, 7-10.
- Waetjen, W. B. (1987). The autonomy of technology. The Technology Teacher. 46 (6), 7-14.

Appendix A

Program objectives for the summer session 1987,
technology education module (course) Diploma of
Industrial Arts program, Memorial University.

Memorial University of Newfoundland
Division of Special Programs
Summer Session 1987

TECHNOLOGY EDUCATION MODULE

Course Goals:

- I. To introduce students to concepts of Technology Education.
- II. To introduce students to computer applications appropriate to secondary level Technology Education.
- III. To make students more aware of contemporary Industrial Technology Developments.

Course Objectives: At the conclusion of this course the student should be able to:

- a. Differentiate between industrial arts, industrial technology, and technology education models.
- b. Prepare initial development of a teaching module consistent with a technology education model.
- c. Apply specific computer programs related to desktop publishing.
- d. Perform basic personal computer operations; loading software, running programs, output to printer and plotter.
- e. Create and output technical drawings on a CAD

system.

f. Combine text and graphic files.

g. Describe operationally how electric motor movements are manipulated by a programmable controller.

Appendix B

Criterion Referenced Tests

Introduction to Technology Education

Test One (Pre-Test)

Name _____

1. Define Technology.
2. Draw a diagram of an open loop system model.
3. Draw a simple diagram of a closed loop system model.
4. What are the three main groupings of technological systems?
5. What are the two main parts of an electronic communications system?
6. What are the four main parts of a computer hardware system?
7. What are the five main functions of a computer software system?
8. What is process control of machines?

Information Communications SystemsComputer Assisted Drafting (CAD)

Test One

Name _____

1. List 5 drawing tools used by a CAD program.

1.

2.

3.

4.

5.

6. List 8 editing tools used by a CAD program.

1.

2.

3.

4.

5.

6.

7.

8.

7. What is a composite drawing?

8. Have you used a CAD system before?

Yes _____

No _____

Physical Systems TechnologyRobotics

Test One

Name _____

1. What are the four main parts of a robot?

- 1.
- 2.
- 3.
- 4.

2. a. What are the three methods of classifying robots?

- 1.
- 2.
- 3.

b. Give two examples of each classification type for robots.

- | | |
|-------|----|
| 1. a. | b. |
| 2. a. | b. |
| 3. a. | b. |

3. What are the three methods of programming robots?

- 1.
- 2.
- 3.

4. What are the four limiting factors on robots?

- 1.
- 2.
- 3.
- 4.

5. Have you programmed a robotics device?

Yes _____

No _____

Information Communications Systems
Desktop Publishing

Test One

Name _____

1. What is the basic function of a desktop publishing program?

1.

2. What are the two basic types of information manipulated by a desktop publishing program?

1.

2.

3. What other two types of programs are used to provide information to desktop publishing programs?

1.

2.

4. List 5 'tools' used by desktop publishing programs.

1.

2.

3.

4.

5.

5. Have you used a desktop publishing system?

Appendix C

Appraisal Checklists

Evaluation Checklist One

Appropriateness of Instructional Content:

Directions: Critically inspect the concept analysis, instructional objectives, and instructional materials. Evaluate them with respect to the goals and objectives of the introduction to technology component of the IA program for teacher trainees. Circle the appropriate number for each response.

Response values are:

- 1 = unacceptable
- 2 = below average
- 3 = average
- 4 = better than average
- 5 = outstanding quality.

- | | | | | | | |
|----|--|---|---|---|---|---|
| 1. | Appropriateness of concepts | 1 | 2 | 3 | 4 | 5 |
| 2. | Sequencing of concepts | 1 | 2 | 3 | 4 | 5 |
| 3. | Completeness of concepts | 1 | 2 | 3 | 4 | 5 |
| 4. | Relevance of the objectives to the general goals of the program. | 1 | 2 | 3 | 4 | 5 |
| 5. | Stated rationale for the objectives | 1 | 2 | 3 | 4 | 5 |
| 6. | Theoretical soundness of the objectives. | 1 | 2 | 3 | 4 | 5 |

Comments:

Evaluation Checklist Two

Content

Critically inspect the instructional package for effectiveness on the following points. Select the answer most appropriate.

- 1 for poor usability
- 2 for average usability
- 3 for good usability

1. For instructional content	1	2	3
2. Level of language	1	2	3
3. Style of presentation	1	2	3
4. Difficulty level	1	2	3
5. Sequence of presentation	1	2	3
6. Appropriateness of instruction	1	2	3
7. Completeness of instruction	1	2	3

Comments:

Evaluation Checklist Three

Feasibility of materials.

Critically inspect the Teachers Guide and Technology Learning Activity manuals. Evaluate the useability of the material on the following scale:

- 1 for poor usability.
- 2 for average usability
- 3 for good usability

1.	Reusability of the materials	1	2	3
2.	Equipment requirements	1	2	3
3.	Space requirements	1	2	3
4.	Preparation time for use	1	2	3
5.	Instruction manuals	1	2	3
6.	Special skills required for use	1	2	3

Comments:

Evaluation Checklist Four

Quality of materials.

Critically inspect the instructional materials for quality of design and construction. Place an 'X' in the blank closest to how you feel about the quality.

- | | | | | | |
|-----|-------------|----|----|----|---------------|
| 1. | unpleasant | -- | -- | -- | pleasant |
| 2. | useful | -- | -- | -- | useless |
| 3. | powerful | -- | -- | -- | weak |
| 4. | effective | -- | -- | -- | ineffective |
| 5. | clear | -- | -- | -- | unclear |
| 6. | relevant | -- | -- | -- | irrelevant |
| 7. | appropriate | -- | -- | -- | inappropriate |
| 8. | interesting | -- | -- | -- | boring |
| 9. | efficient | -- | -- | -- | inefficient |
| 10. | valuable | -- | -- | -- | valueless. |

Comments:

Evaluation Checklist Five
Usefulness to the Client.

Directions: Critically inspect the concept analysis, instructional objectives, and instructional materials. Evaluate them with respect to the goals and objectives of the introduction to technology component of the IA. program for teacher trainees.

Circle the appropriate number for each response.

Response values are:

- 1 = unacceptable
- 2 = below average
- 3 = average
- 4 = better than average
- 5 = outstanding quality

- | | | | | | | |
|----|---------------------------------|---|---|---|---|---|
| 1. | Material is worth implementing. | 1 | 2 | 3 | 4 | 5 |
| 2. | Material is in a usable form. | 1 | 2 | 3 | 4 | 5 |
| 3. | Material fits teaching methods. | 1 | 2 | 3 | 4 | 5 |
| 4. | Project is valuable to you. | 1 | 2 | 3 | 4 | 5 |
| 5. | Fits the curriculum. | 1 | 2 | 3 | 4 | 5 |
| 6. | Appropriate time available. | 1 | 2 | 3 | 4 | 5 |

Comments:

Evaluation Checklist Six

Evaluation Experience.

Please fill in this questionnaire to indicate how you feel about this instructional material. Select the answer closest to how you perceived the material.

- | | | | | |
|-----|-------------|----|----|---------------|
| 1. | unpleasant | -- | -- | pleasant |
| 2. | useful | -- | -- | useless |
| 3. | powerful | -- | -- | weak |
| 4. | effective | -- | -- | ineffective |
| 5. | clear | -- | -- | unclear |
| 6. | relevant | -- | -- | irrelevant |
| 7. | appropriate | -- | -- | inappropriate |
| 8. | interesting | -- | -- | boring |
| 9. | efficient | -- | -- | inefficient |
| 10. | valuable | -- | -- | valueless |
| 11. | worthwhile | -- | -- | worthless. |

Appendix DActivity schedule for
Technology Learning Activities

GROUP	Monday		Tuesday				Wednesday		Thursday	
	AM	PM	AM	PM	AM	PM	AM	PM		
A	Intro	R1 D1 D1	C1 R2 C1	C1 C2 C2	R3 D2	D2 C2 C2	C2 C2 C2	C2 C2 C2		
B	Intro	C1 R1 C1	D1 D1 R2	C1 C2 C2 C2	R3 C2	C2 D2 D2	C2 C2 C2	C2 C2 C2		
C	Intro	C1 C1 R1	C1 C2 D1	D1 R2 C2	C2 C2 C2	R3 C2	C2 D2 D2	C2 C2 C2		
D	Intro	C1 C1 C1	R1 C2 C2 C2	C2 R2	D1 D1 C2	C2 R3	C2 C2 C2	D2 D2 D2		

INTRO - AN OVERVIEW OF TECHNOLOGY/CONCEPT ANALYSES

C1 - CAD TLA 1

C2 - CAD TLA 2

R1 - ROBOTICS TLA 1

R2 - ROBOTICS TLA 2

R3 - ROBOTICS TLA 3

D1 - DESKTOP PUBLISHING TLA 1

D2 - DESKTOP PUBLISHING TLA 2

Appendix E

Teachers Guide

And

Instructional Materials

for

TECHNOLOGY EDUCATION:

WITH SPECIFIC APPLICATIONS IN INDUSTRIAL TECHNOLOGY

Instructors Manual
for
Technology Education:
With Specific Applications in Industrial Technology

Leon Cooper

Table of Contents

Introduction	1
------------------------	---

Chapter 1

An Overview of Technology	4
1. Technology	5
Definition of Technology	5
Nature of technology	6
2. Systems	8
3. Technological Systems	9
4. The Nature of Technological Systems	10
5. Technological Systems Organization	14
6. Information Communications Systems	15
7. Electronic Communications Systems	16
8. Physical Systems	18
9. Bio Systems	20
10. Relationship of current Industrial Education program to Technology Education	21

Chapter 3

Technology Learning Activities	23
1. Introduction to the Activities	23
Computer Assisted Drafting	23
Robotics	26
Desktop Publishing	29
2. Review	33
Appendix A	Concept Analyses
Appendix B	Task Analyses
Appendix C	Overhead Transparency Masters.
Appendix D	TLA Schedule

Introduction

The purpose of Technology Education: Specific Applications in Industrial Technology is to provide the Industrial Education student with an overview of technology, and some hands on experiences in specific technologies.

The 30 hour course consists of An Overview of Technology (a three hour introduction to technology, technological systems, and technological systems organization), followed by a one hour introduction to three specific technologies, and twenty-six hours of Technology Learning Activities (TLAs) in these technologies.

The technologies chosen are representative samples of advanced technologies. Computer Assisted Drafting (CAD) and Desktop Publishing (DTP) are representative of advanced Information Communications Technologies. Process Control (Robotics) activities are representative of Physical Technologies.

TLAs consist of a package of instructions to enable the student to work through a specific activity with minimal help from the instructor.

There are two CAD TLAs totaling 16 hours, two Desktop Publishing TLAs totaling 4 1/2 hours, and three Robotics TLAs totaling 5 1/2 hours.

The introductory section, An Overview of

Technology, should be delivered to the student in a lecture format following the guidelines provided in Chapter 1 of this manual. Overhead transparency masters (Appendix C) are provided to give visual cues to the learner. Instructors are encouraged to use the equipment in the laboratory to illustrate technological concepts covered in this section. This is particularly important when teaching computer hardware and software systems.

The one hour session allocated for introducing the three technologies chosen for this course can best be utilized by explaining the concept analysis for each technology. Refer to Chapter 2 for more details.

The TLAs contain an overwhelming volume of information if they are all given to the learner at one time. It is important that a schedule similar to the one in Appendix D be followed and that students be given each TLA according to the schedule. Chapter 3 provides an overview of the TLAs.

Equipment Requirements for TLA's

Equipment requirements are set down in each
TLA.

The minimum total requirements for 10 students are:

CAD: 4 MS-DOS compatibles with 640k
and a MathCoprocessor
1 Plotter
AutoSketch Enhanced CAD program
Logitech Bus Mouse or Microsoft
Mouse

Robotics: 2 MS-DOS compatibles with at
least 256k and GWBasic
fischertechnik Computing Kit
fischertechnik IBM interface
Roland plotter

Desktop Publishing:
2 Amiga computer systems
PageSetter program
1 parallel port dot matrix
Printer.

Equipment Requirements for Teaching

1 VHS VCR and monitor
1 overhead projector and screen
chalkboard

Materials Required for TLA's

TLA manuals and materials listed in each manual.

Materials Required for Teaching

- a. Overhead Transparencies made from Masters in this manual (OV-xx series) (Appendix)
- b. Videotape Fundamentals of Industrial Robotics by Meridan Educational Corporation
- c. Appropriate paper for printer and plotter.

References:

- Goetsch, David L. and Nelson, John A. (1987). Technology and You. Albany, New York: Delmar Publishing Inc.
- Hacker, Michael and Barden, Robert A. (1988). Living with Technology. Albany, NY.: Delmar Publishers.
- Hacker, Michael and Barden, Robert A. (1987). Technology In Your World. Albany, NY.: Delmar Publishers.

Chapter 1

An Overview of Technology

Notes

General Objective:

To provide an overview of technology and the development of industrial technology, and place the current industrial education program into that frame of reference.

The concept analysis (CA, Appendix D) provides an overview for this unit and should be referred to constantly while teaching the introduction.

Students should be provided with a copy of this diagram.

1. Technology

a. Purpose: to

- i. provide a working definition of technology
- ii. distinguish technology from science
- iii. show the interdependence of the two.

Teaching Aids: OV-1

i. Definition of Technology:

Technology is the use of knowledge to turn resources into the goods and services that society needs.

ii. Science:

is the study of why natural things occur the way they do.

- iii. Technology takes advantage of scientific principles, sometimes without a knowledge of how the principle works. Science often depends of the advancement of technology to develop the tools needed to pursue te science.

b. Purpose: to show

- i. technology covers a continuum of activities and levels of sophistication, in terms of

design, development and use of technology.

Teaching Aids: OV-1

i. Technology affects people.

People create technological devices and systems to satisfy basic needs and wants. Technology is responsible for a lot of human progress.

Technology has created a number of human problems.

Nature of technology:

The sum of all human knowledge.

Making things work better.

The means by which people control and modify their environment.

The practical application of science.

A disciplined process that uses scientific, material, and human resources to achieve human purposes.

c. Purpose:

- i. to illustrate the development of technology over time.

Teaching Aids: OV-2.

i. When did Technology begin?

Stone Age: 1,000,000 BC to 3,000 BC

Bronze Age: 3,000 BC to 1000 BC

Iron Age: 1200 BC to 250 BC

After the Iron Age, technology began to grow more rapidly.

In fact technology is now growing at an exponential rate. The level of technology is doubling in increasingly shorter increments of time.

d. Purpose: to show

- i. Technology can be classified by eras of time
- ii. Each technological era was the major employer during its peak
- iii. we are currently in a new technological era.

Teaching Aids: OV-3

i., ii., iii.

Technological ERA's

Agricultural ERA: began about 8000 BC and was major employer until about 1800.

Industrial ERA: began about 1750 with industrial revolution and was major employer until 1950-60.

Information ERA: began about 1950 and is presently the major employer.

2. Systems

a. Purpose: to show

- i. how an open loop system works and
- ii. how a closed loop system works.

i., ii.

The Systems Model

One method of understanding how a particular technology works is as a system.

There are two basic system models:

Open Loop System

Teaching Aids: OV-4

There is no feedback with this system.

ii. Closed Loop System

Teaching Aids: OV-5

There is monitoring and feedback with this system.

3. Technological Systems.

a. Purpose: to show

- i. how technology can be organized and explained using the systems model.

Teaching Aids: OV-1

- i. Discuss examples of open and closed loop technological systems.

Some technological systems are:

cruise control on a car

sump pump

street light

thermostat

4. The Nature of Technological Systems

a. Purpose: to show

- i. that resources are needed for technological systems.
- ii. the resources of technological systems.

i. Technological Systems Need Resources

Teaching Aids: OV-1

Discuss the problems involved in creating something, ie. resources are needed.

ii. Technological Systems use Resources

Teaching Aids: OV-6

The resources of technology are:

people	(make policies,
	labour, ideas,
	consume)
information	(communicate, share,
	data, process,
	collect, create

knowledge)

materials (natural and raw -
to make products -,
limited and
unlimited)

tools and machines (hand, machine,
electronic,
optical)

energy (renewable - human,
animal, wood;
limited - coal, oil,
gas, nuclear fission,
unlimited - wind,
geothermal, solar,
tidal, gravitational,
and nuclear fusion)

capital (money, shares,
dividends, interest)

time (by daylight, then
hours, then minutes,
then seconds, now
nanoseconds
(billionths) for
processing data - ie
done near the speed
of light)

b. Purpose: to show

- i. Technological systems may have multiple outputs.
- ii. technological systems may have four kinds of outputs

i. Multiple Outputs

Teaching Aids: OV-1

One operation may produce several products (byproducts)

Examples:

A manufacturing system may produce the products that are needed and some that are not needed.

An oil refinery produces a number of products from the same plant using the same raw materials.

- ii. Technological systems produce four kinds of output

Teaching Aids: OV-7

1. expected and desirable
2. expected undesirable
3. unexpected desirable
4. unexpected undesirable

5. Technological Systems Organization

a. Purpose: to show

1. one method of organizing technological systems.

Teaching Aids: OV-1

1. Systems Organization

Teaching Aids OV-8

One method is to group all technologies into three major headings

Information
Communications Systems

Physical
Systems

Bio-
Systems

6. Information Communications Systems.

- a. Purpose: to show
- i. the processes of information communications.

Teaching Aids: OV-9

- i. Information Communications Processes
Information communications processes are independent of the technologies used. The processes are:
 - use of symbols
 - use of words
 - thinking.

- b. Purpose: to show
- i. some of the technologies of information communications.

Teaching Aids: OV-10

- i. Information Communications Technologies
For our purposes, communications technologies may be divided into:
 - nonelectronic
 - electronic

7. Electronic Communications Systems.

a. Purpose: to show

- i. the components of one type of electronic communications system
- ii. two examples of that type of communications system.

i. Electronic Communications System

Teaching Aids: OV-11

Electronics communications can be by a number of means: telephone, radio, television, satellite.

Electronic communications of interest to this course are all based on the use of a computer to produce a product that will be used to communicate ideas. The product may be used independently of the computer.

Discuss the hardware requirements for a computer system and software operation in general terms.

Hardware:

Input Device
CPU
Storage Device
Output Device

Software:

Load
Save
Input
Output
Process

ii. Examples of Computer Related Electronics
Communications Systems

Teaching Aids: OV-11

Two examples are:

CAD

Desktop Publishing

Discuss the hardware and software
requirements for each.

4

8. Physical Systems.

a. Purpose: to show

- i. the major subsystems of physical systems
- ii. to show one example of an advanced physical technological system

i. Physical Systems

Teaching Aids: OV-12

The major physical technology systems are:

manufacturing
power and energy
construction
transportation

ii. Advanced Physical Technology System

Teaching Aids: OV-12

Process Control

Process control is the control of a physical machine (tool or machine) by a logic machine (computer), i.e.,

a cybernetic device.

Process control may require a separate computer, or the logic device may be built into the physical machine.

This course is concerned with computers that are external to the physical machine.

An Advanced Physical Process Control System:
Robotics

Teaching Aids: OV-12

Robots are excellent examples of cybernetic devices. They consist of a physical machine with varying degrees of mobility. They perform a variety of tasks. All operations are under the control of a logic device which can be programmed to give the robot different characteristics.

9. Bio Systems

a. Purpose: to show

i. the major subsystems of bio technology systems.

i. Bio Sub-Systems

Teaching Aids: OV-13.

The three major bio subsystems are:

Agriculture

Health and medical

Marine.

10. Relationship of current Industrial Education program to Technology Education

a. Purpose: to show

- i. the relationship of the current industrial education program to technology education.

- i. Relationship to Current Industrial Education Program

Teaching Aids: OV-1

Show that the current program has components in all three of the major technological systems.

Information Communications systems

drafting

electronics

Physical systems

woods

building construction

metals

plastics

power and energy

home maintenance

electricity (house wiring)

Bio systems**, marine industries**

Emphasize that the current program can be considered a subset of technology education. Technology covers a broader spectrum than industrial education. Industrial education is concerned with the practices of industry. Technology education is concerned with all aspects of technology, including how it is created, used, controlled, and its effects on the person and society.

Chapter 2

Technology Learning Activities

1. Introduction to the Activities.

a. Purpose: to provide students

1. with an overview of each technology

Computer Assisted Drafting

Robotics

Desktop Publishing

1. The Activities

Using the concept analysis for each technology (provided in Appendix A), describe the major concepts and equipment for each technology.

Computer Assisted Drafting.

Emphasize the use of basic drawing primitives or "drawing elements". Describe the use of drawing elements to create composite drawings, the use of editing tools, and the use of drawing aids.

Robotics.

Emphasize the use of process control, the basic components of robots, methods of classifying robots, programming methods, and the major limitations of robots.

Desktop Publishing.

Describe the 'desktop environment' concept before covering page creation, box creation and modification, the use of the Text Editor, and the use of the Graphic Editor.

Chapter 3

Technology Learning Activities

Purpose:

a. to provide:

1. an overview of the requirements of each TLA.

1. Technology Learning Activities.

An overview of each TLA is provided on the following pages. The purpose of each TLA is given, along with a brief discription of the TLA.

Computer Assisted Drafting

Teaching Aids: CA.CAD

Emphasize the relationship of the CAD operation to regular drafting.

Describe the drawing elements (line, box, etc.) or 'tools' as drawing primitives that can be combined to produce composite drawings.

Explain that drawing elements are stored by the computer as logical mathematical entities. The location and physical characteristics of each is stored in a data base.

Emphasize the editing features in terms of manipulating the data in the data base. For example, rotating an object changes only the objects location data, but stretching an object also changes its physical characteristics

Explain the Assist tools in terms of

providing drawing assistance under special conditions.

CAD TLA 1

Purpose:

- i. introduce basic CAD principles
- ii. produce a simple drawing.

Requires 2 to 3 hours, and introduces the basic drawing elements and editing tools. An exercise is provided with each. The final section requires the student to produce and save a drawing.

CAD TLA 2

Purpose:

- i. practice drawing elements, editing tools, and drawing assist tools
- ii. produce, save, and plot a complex dimensioned composite drawing.

Requires 13 to 14 hours, and gives most^o

of the other features of the program. The final activity is to produce, save and plot a drawing. Students who finish early may be provided with other drawings.

Observe and encourage student use of drawing aids. Also encourage use of editing tools like copy, undo, and rotate.

Stress the use of part libraries to speed production.

Robotics

Teaching Aids: OV-CA.ROBOTICS

Videotape Fundamentals of Robotics

Emphasize the logic/physical machine link and the use of a computer for process control.

Have students view the videotape upon completion of all robotics TLAs.

This course depends more on the working envelope coordinate classification system.

Process Control - TLA 1

Purpose:

- i. provide experience with closed loop process control systems.

The fischertechnik kit must be assembled prior to commencement of the activity due to time constraints. See the instructions

in the TLA for assembly.

This activity uses a simulated pedestrian crossing light to introduce the principles of closed loop process control. The computer maintains a constant green light for traffic. When the pedestrian button is pushed, the cycle is interrupted, and the computer uses the programmed times for the yellow and red lights to control traffic flow. Encourage discussion of industrial situations that could benefit from this procedure.

Robotics - TLA 2.

Purpose:

- i. Provide experience with rectilinear coordinate robot systems.
- ii. program the robot to provide different outputs.
- iii. run (execute) the program

A Roland flatbed plotter is used as a

rectilinear coordinate robot. There is x and y axis movement and limited z axis movement (pen up/down). The device is controlled by a basic program.

Robotics - TLA 3

Purpose:

- i. provide experience with cylindrical coordinate robot systems
- ii. program a pick and place robot using manual programming
- iii. execute the program.

This activity uses a fischertechnik computing kit configured as a cylindrical robot. The robot must be assembled prior to commencement of the activity, since there is not enough time for the students to construct it.

Emphasize that the robot memory must be cleared and reprogrammed after every 'Execution' of the program. This is done by exiting the program and running it

again. Failure to do so can cause damage
to the device.

Desktop Publishing

Teaching Aids: OV-CA.DTP

Although desktop publishing appears to be a complex task, the principles are rather simple.

The desktop environment is a visual layout produced on the computer screen to mimic a desktop. There is a working surface or desktop called the artboard. Pieces of text and pictures are manipulated in boxes and may be placed on the artboard and removed at any time.

Pages may be created on the artboard and magnified to one of three levels of magnification.

Boxes may be created to hold text and graphics (pictures). Boxes may be modified (edited) at any time.

Text (and other box) characteristics may be set prior to box creation (defaults)

or after box creation (current).

Emphasize the principles of text boxes and graphic boxes in terms of cut and paste for manual layout of pages.

The Page layout program may take its input from two basic sources:

The Text Editor. This editor is a basic word processor. Files can also be imported from any other wordprocessor.

The Graphic Editor. This is a very basic drawing program. Drawings may also be imported from any other drawing program or from a digitizer.

Desktop Publishing - TLA 1

Purpose:

- i. introduce students to basic principles of DTP
- ii. use the text editor to load and edit text.
- iii. produce and print a simple

page.

This activity should take less than 2 hours to complete.

Ensure that students check off each step as it is complete. This will prevent many problems with completing the exercise.

Desktop Publishing - TIA 2

Purpose:

1. produce and print a page with the following:

Title

Graphic

four blocks of text.

Emphasize the use of magnifying and grid on/off as aids in box placement and alignment.

Ensure that students remember to set the defaults before creating a page or a box. Otherwise they must reset the current

page or box to the desired values.

2. Review

Purpose: to reinforce the concepts covered in the
TLA's

Review the basic principles covered
in each TLA.

7

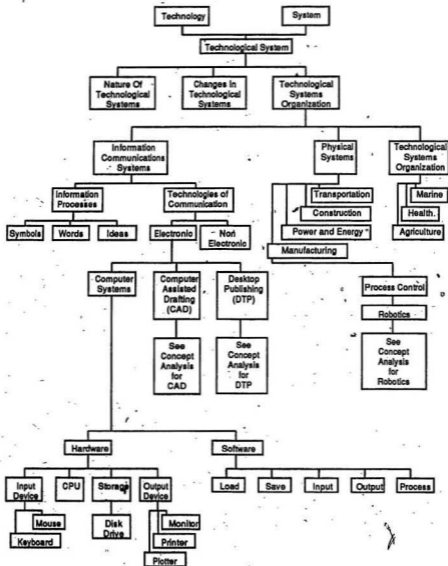

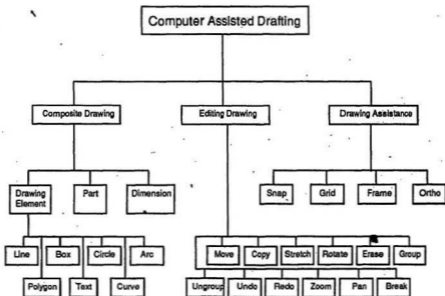

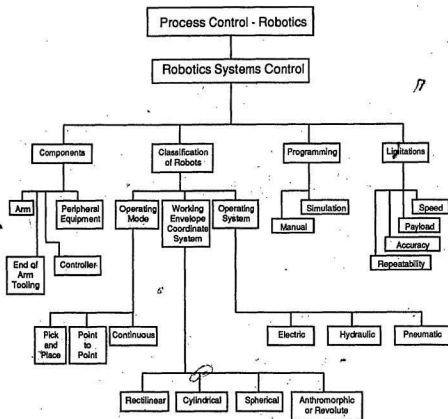

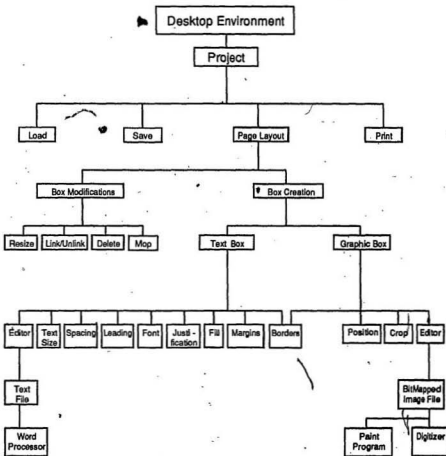

Appendix B

261

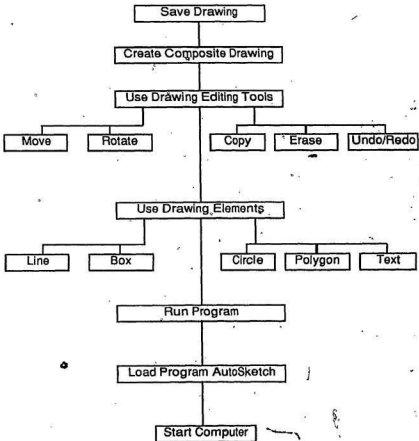

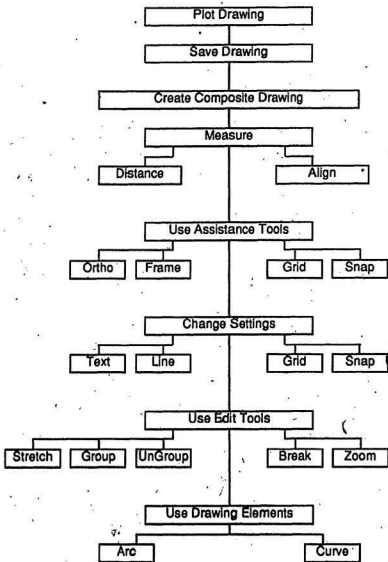

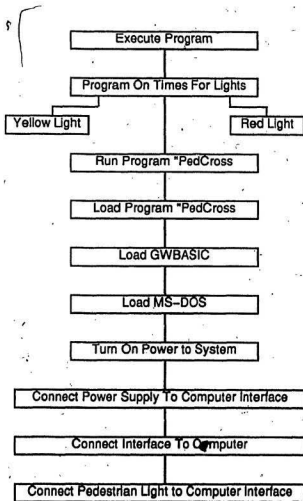

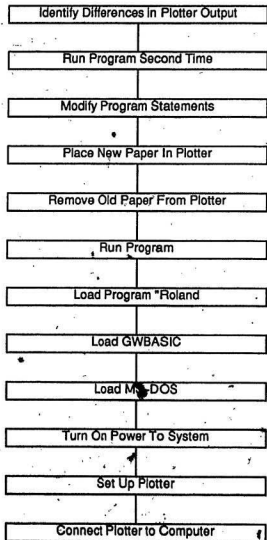

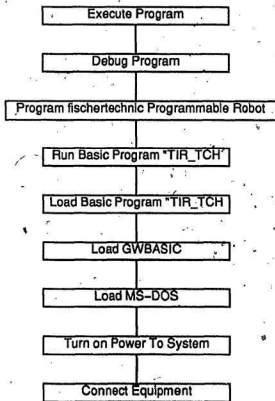

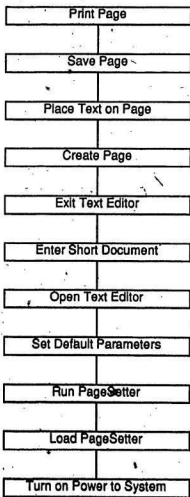

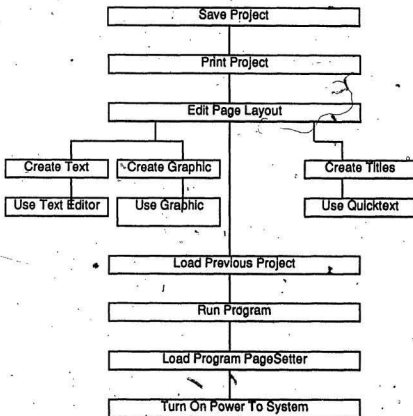

TECHNOLOGY

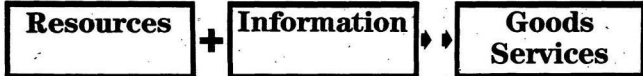

SCIENCE

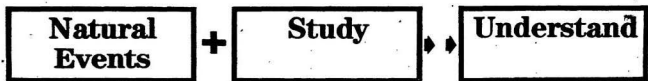

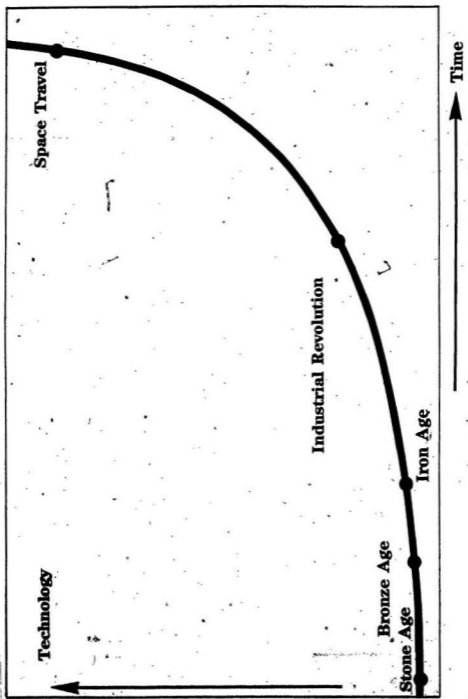

Growth of Technology

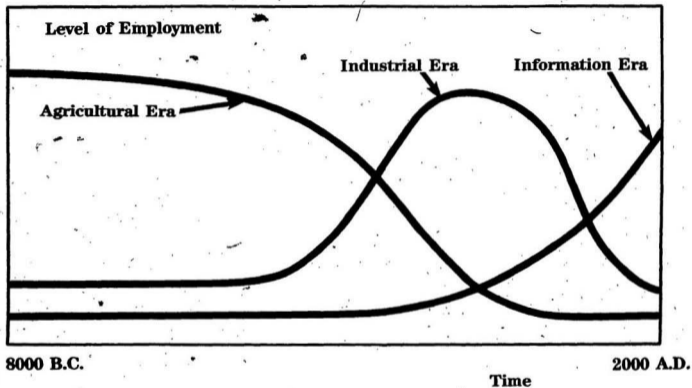

Technological Eras

Open Loop System



Closed Loop System

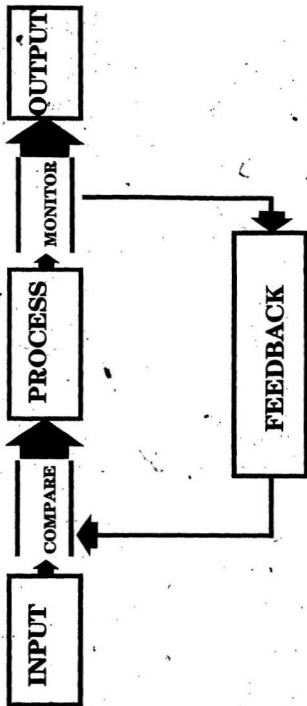

Resources

- **People**
- **Information**
- **Materials**
- **Tools and Machines**
- **Energy**
- **Capital**
- **Time**

↑ **Output 1**

↑ **Output 2**

↑ **Output 3**

↑ **Output...**

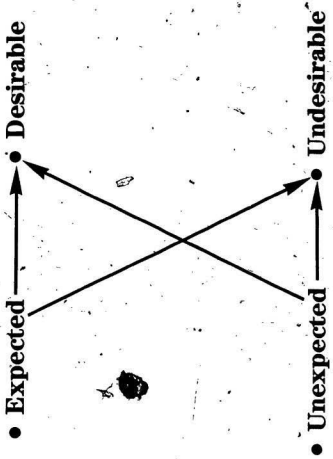

↑
Outputs

Technological Systems Organization

```
graph TD; A[Technological Systems Organization] --> B[Information Communications Systems]; A --> C[Physical Systems]; A --> D[Bio Systems];
```

The diagram is a hierarchical organizational chart. At the top is a rectangular box containing the text "Technological Systems Organization". A vertical line descends from the center of this box to a horizontal line. From the left, center, and right ends of this horizontal line, three vertical lines extend downwards to the top centers of three separate rectangular boxes. These three boxes are arranged horizontally and contain the text "Information Communications Systems", "Physical Systems", and "Bio Systems" respectively.

**Information
Communications
Systems**

**Physical
Systems**

**Bio
Systems**

Information Communications Systems

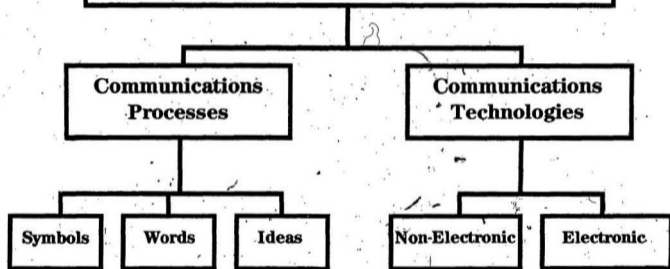

Electronic Communications Systems

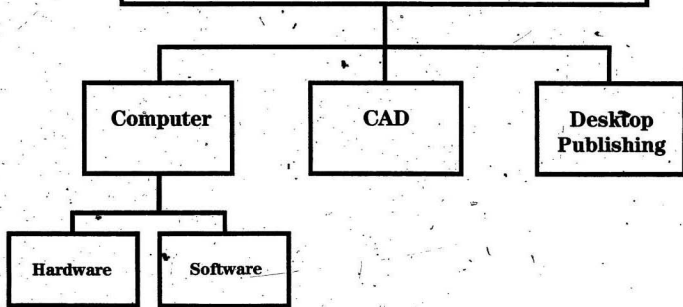

Physical Systems

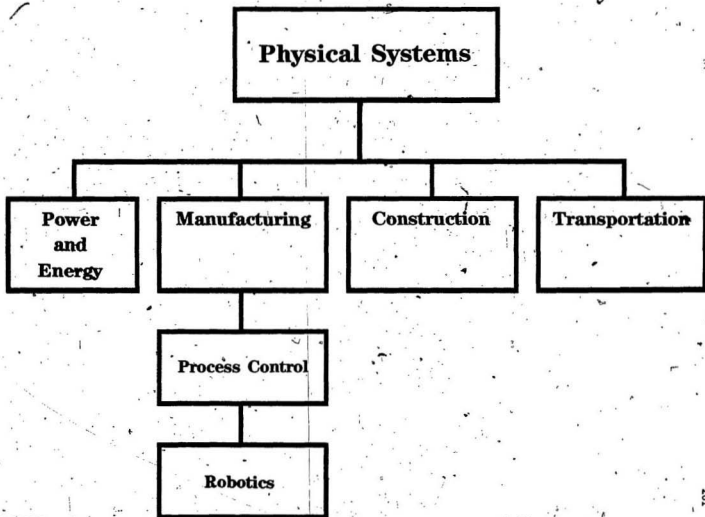

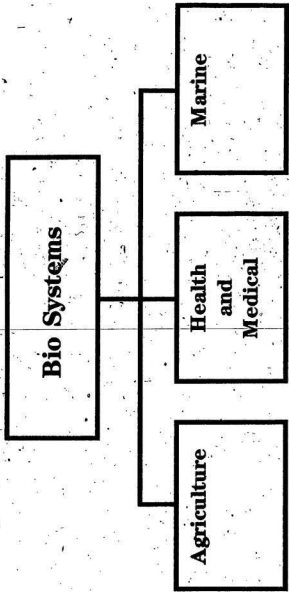

GROUP	Monday		Tuesday				Wednesday				Thursday			
	AM	PM	AM	PM	AM	PM	AM	PM	AM	PM	AM	PM		
A	Intro	R1 D1 D1 C1	R2 C1 C1 C2 C2	R3 D2 D2 C2 C2 C2 C2 C2										
B	Intro	C1 R1 C1 D1 D1	R2 C1 C2 C2 C2	R3 C2 C2 D2 D2 C2 C2 C2 C2										
C	Intro	C1 C1 R1 C1 C2 D1 D1	R2 C2 C2 C2 C2	R3 C2 C2 D2 D2 C2 C2 C2										
D	Intro	C1 C1 C1 R1 C2 C2 C2 C2	R2 D1 D1 C2 C2	R3 C2 C2 C2 D2 D2										

INTRO - AN OVERVIEW OF TECHNOLOGY/CONCEPT ANALYSES

C1 - CAD TLA 1

C2 - CAD TLA 2

R1 - ROBOTICS TLA 1

R2 - ROBOTICS TLA 2

R3 - ROBOTICS TLA 3

D1 - DESKTOP PUBLISHING TLA 1

D2 - DESKTOP PUBLISHING TLA 2

Technology Education:

285

With Specific Applications in Industrial Technology

Information Communications Technology

Computer Assisted Drafting

Technology Learning Activity 1

Leon Cooper

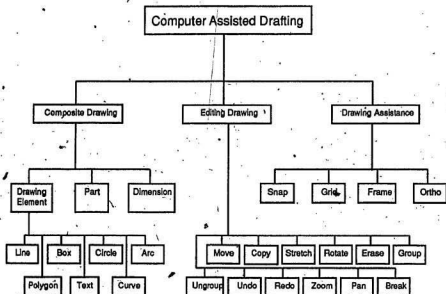

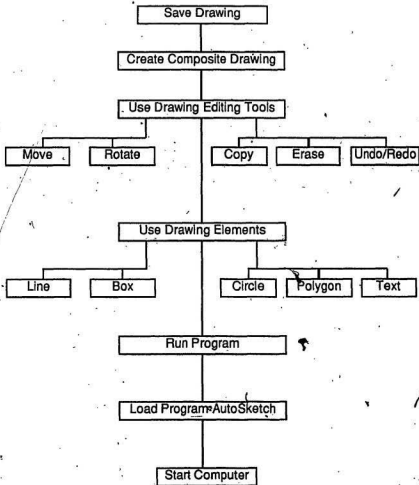

Computer Assisted Drafting
Technology Learning Activity 1

288

General Objective

Upon completion of this activity, the student will be able to use a Computer Assisted Drafting (CAD) program to create simple drawings and save them to a computer storage device.

Specific Objectives:

The student will be able to successfully complete the following objectives within a one and one half hour time limit. Success will be measured by the presence of a CAD file created by the student and saved on a computer floppy disk.

1. Load the CAD program into the computer.
2. Run the CAD program.
3. Use the drawing elements line, box, circle, polygon, and text to create a series of images on the computer screen.
4. Edit the drawing elements using the editing tools move, rotate, copy, erase, and undo.
5. Combine the drawing elements line, box, circle, polygon, and text to create a simple composite drawing.
6. Save the completed drawing to a floppy disk.

Equipment Required

MS-DOS Computer with 640k memory and a Math Coprocessor
CAD Program AutoSketch
Mouse (Logitech Bus Mouse or Microsoft Mouse)

Instructional Materials Supplied

Computer Assisted Drafting Technology Learning Activity 1 instructional package.
Quick Reference Guide for AutoSketch
Data storage Disk for AutoSketch

Menus and Mice

The program uses a mouse as an input device. Moving the mouse around on the desk moves the pointer on the screen. The mouse has three buttons, but the center button is not used by this program. Both the outside buttons have the same effect. Operations are performed with the mouse by moving the pointer on the screen and clicking and releasing the mouse.

This program is menu driven. That means all operations are selected from a menu. The main menu items are visible across the top of the screen.

Menu selections are made by moving the pointer to the top of the screen on the desired option and pressing the button once. The list of items available under that option drops down beneath the selected option. Move the pointer to the desired item and click again. The selection will be loaded into the computer.

There is a status line across the bottom of the screen. AutoSketch displays information or makes requests below this line when you are expected to enter information into the computer. The first word displayed is the name of the operation you are performing (ie Line if you are drawing lines). The remainder of the words ask for input from the user.

Drawing Elements

Drawing elements are the basic components of a drawing. They are treated as individual objects by the CAD program, and they exist as mathematical constructs in the computer. If you 'blow up' or zoom in on a line, for example, it does not get any thicker on the screen.

Computer Assisted Drafting
Technology Learning Activity 1

290

Drawing elements used by this program are:

Arc

Circle

Line

Point

Text

Box

Curve

Part

Polygon

Procedure

Loading the Program.

1. COMPUTER WITH HARD DRIVE.

a. Turn on computer.

b. When the prompt

C > appears

type the following:

cd sketch

The prompt

C> \sketch >

will appear on the screen.

c. type

sketch

Press the Return Key and the program will load.

2. COMPUTER WITH 2 FLOPPY DRIVES.

a. Insert MS-DOS disk into drive A (top drive).

b. Turn on computer. The computer will proceed to load the operating system

c. The prompt

A >

will appear on the screen.

d. Remove the MS-DOS disk and

insert the AutoSketch program disk into drive A and

insert the Data disk (drawing storage disk) into drive B.

e. Type

sketch

Press the Return Key and the program will load.

Using Drawing Elements

1. Drawing Element: Lines.

Purpose: to draw lines

a. Select the 'Draw' menu.

b. Select the 'Line' option

c. The status line at the bottom of the screen displays

Line Enter point

d. Move the pointer to the location where the line will begin, and click the button.

e. The status line displays

Line To point

f. Move the pointer to the location where the line will end.

Notice that the line follows the pointer around (known as rubberbanding).

g. When the end is located click the button again.

The line is fixed in place, and the status line returns to the prompt

Line Enter point

h. Draw a series of lines on the screen.

Try to create horizontal lines, vertical lines, and angled lines.

2. Clearing the Screen

Purpose: to clear the screen and delete the drawing

- a. When finished, clear the screen by selecting the 'File' menu.
- b. Select new from the list of options.
- c. A box will appear on the screen showing three choices:

Save Discard Cancel

- d. Select

Discard

This will clear the screen without saving the drawing to disk.

3. Drawing Elements: BOXES

Purpose: to draw boxes

- a. Select 'Box' from the 'Draw' menu.

The status line will show

Box First corner

- b. Use the mouse to locate the first corner. Don't forget to click the button.

The status line shows

Box Second corner

- c. Drag the pointer to the second corner (in any direction) and click the button.

Notice the rubberbanding effect for the box as well.

The status line shows

Box First corner

indicating that the program is ready to draw another box.

d. Draw a dozen or so boxes and then clear the screen by selecting 'Files' -- 'New'.

4. Drawing Elements Circles

Purpose: to draw Circles

a. Select 'Circle' from the 'Draw' menu.

The status line will show

Circle Center point

b. Select the center point on the screen.

The status line will show

Circle Point on circle

indicating that you should drag the circle out to its required size.

c. Drag out to the size. Select the size (click button).

Notice that a smooth circle is drawn.

The status line now shows

Circle Center point

indicating that another circle can be drawn.

d. Draw a dozen or so circles and then clear the screen.

5. Drawing Elements: Polygon
Purpose: to draw polygons

- a. Select 'Polygon' from the 'Draw' menu.

The status line shows

Polygon First point

- b. Select a starting point.

The status line now shows

Polygon To point

- c. Drag the pointer and locate the second point.

The status line again shows

Polygon To point

- d. Continue this three more times and on the third time return to the first point to close the polygon.

Note that this process of rubberbanding to the next point will continue until the polygon is closed.

After the polygon is closed the status line will return to

Polygon First point

- e. Draw another dozen or so polygons (clearing the screen as necessary) and then clear the screen.

6. Drawing Elements: Text
Purpose: to enter text into the drawing

- a. Select 'Text' from the 'Draw' menu.

The status line will show

Text Enter point

Note that the point selected will be the base of the first character in the text entry.

The only editing possible if an error is made, is to backspace to the error and type the text in again.

After the text is entered and placed, it can only be erased with the 'Edit' tool 'Erase'.

b. Locate the point that you wish text entry to begin.

Enter the text

"CAD is easy, CAD is Great, I Think!"

or anything you wish.

Remember to press return before getting to the edge of the screen.

c. Experiment with text entry for a few minutes and then clear the screen.

Editing Drawing Elements

Quite often drawing elements are not created in the right location, have the wrong angle, more than one copy of an element is needed, an element must be removed from the drawing, or an operation gets performed that should not have been performed. Editing is the process of correcting those problems.

Editing functions are located in the menu selection 'Change'

Most editing functions require that an object be selected, then a reference point or base point be selected on the object, and finally a new location point or insertion point be selected on the drawing. The drawing is then moved or copied to that location.

1. Editing Function: Move

Purpose: to move one or more drawing elements

a. Draw an object on the screen (line, box, etc)

- b. Select 'Move' from the 'Change' menu.

The status line shows

Move Select object

and a pointing finger appears on the screen.

Use the tip of the finger to select the object to be moved.

- c. Select the object to be moved by pointing to any edge on the object.

The status line shows

Move Enter point

The point being requested will be the reference point on the object. Click on any point on the object.

For example, the bottom left corner of a box makes a good reference point. This point on the object will be placed at the new location.

- d. Select a point on the object as the base point.

The pointer attaches itself to the object at that location.

The status line reads

Move Enter point

The point being requested now is the new location.

- e. Move the object to the desired location and click the mouse button.

- f. Practice this operation a few times and then clear the screen.

NOTE: If an object is selected to be moved while the pointer is not touching an edge of the object (ie. click the button before touching the object edge with the pointer), the status line reads

Move Crosses/window corner

Dragging the pointer now creates a box.

All the objects inside the box can then be moved in the same fashion as a single object.

Follow the status line prompts to pick the base point on the objects and the new location (insertion point in the drawing) point for the objects.

2. Editing Function: Rotate

Purpose: to rotate one or more objects on the drawing

- a. Select 'Rotate from the 'Change' menu

The status line shows

Rotate Select object

- b. Select the object to be rotated.

The status line shows

Rotate Center of rotation

- c. Select the point that you wish the object to rotate around.

The status line shows

Rotate Second point

- d. Move the pointer to a new location. A line rubberbands from the rotation point to the current pointer location.

The status line now has

Rotate Second point (Angle: 246)

The actual angle depends on the current pointer location.

- e. When you are satisfied with the position click the button to accept.

The status line returns to

Rotate Select object

f. Experiment with several objects and rotations,
then clear the screen..

3. Editing Function: Copy

Purpose: to make copies of one or more
objects and place them in
another location on the
drawing.

Copy can be used to copy one object or more than
one object at the same time.

One object is copied by selecting a point on the
object.

Several objects are selected by drawing a box
around them in the same fashion as in the 'Move'
command.

a. Draw several objects.

b. Select 'Copy' from the 'Changes' menu.

The status line shows

Copy Select object

c. Either

Select the object required by pointing to an
edge

or

Select a group of objects by clicking the
button near the objects and then dragging out
to get a box around the objects.

When done, the status line will read

Copy.. Enter point

- d. Select the reference point on the object(s)
The status line reads
Copy Enter point
- e. Move the pointer to a new location.
The copied objects follow the pointer.
Select the new location.
- f. Make several copies and then clear the screen.

4. Editing Function: Erase
Purpose: to erase objects

Erasing an object removes it from the screen and from the drawings' database.

To erase an object select a point on the object, or surround it with a box.

To erase text select the baseline of the text.

- a. Select 'Erase' from the 'Change' menu.
The status line shows
Erase Select object
- b. Select an object.

The object is erased immediately and the status line remains the same.

5. Editing Function: Undo/Redo
Purpose: to undo an operation or to redo an operation that has been undone

Undo and Redo are listed as two separate functions under the change menu.

Undo will remove the last change made to the ...

drawing. If the last operation was to add an object, undo will remove it. If the last operation was to erase an object, undo will restore it. Undo can be used to step backwards through several operations.

Redo is the opposite of Undo. It will reverse the effects of the last Undo operation. It can also step back through a number of Undo operations.

There is no status line prompt for either of these operations, since the effect is immediate and obvious.

- a. Perform several operations including creating and editing objects.
- b. Select 'Undo', from the 'Changes' menu. Notice the effect on the drawing.
- c. Select 'Redo' from the 'Changes' menu. Notice the effect on the Undo operation.
- d. Select Undo several times, then select Redo several times.
- e. When done clear the screen.

Creating Composite Drawings

Composite drawings are made from combinations of drawing elements.

By creating two or more drawing elements on the screen you have already made composite drawings.

This section will develop your ability to create structured composite drawings.

Look at the drawing on the next page. Analyze it in terms of lines, boxes, circles, polygons, and text elements. Try to use a box instead of four lines to create a rectangle. Use a polygon instead of a series of lines.

- a. Construct the drawing on the screen.

Use the drawing elements and editing tools as necessary.

Computer Assisted Drafting
Technology Learning Activity 1

302

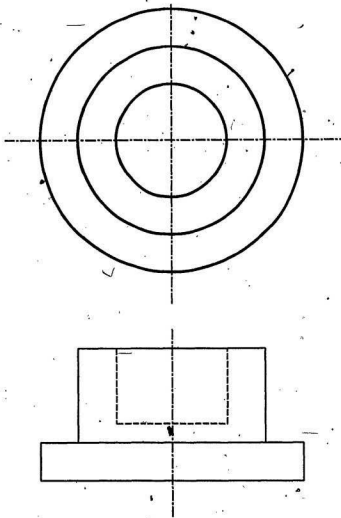

Saving Drawings

Drawings must be saved to some storage device if you wish to keep them for later use. This drawing will be saved to a floppy disk.

There are two methods of saving.

'Save As' is used if the file is being saved for the first time or if you wish to save this version of the drawing and keep the original drawing as well.

'Save' is used if you wish to replace the original version of the drawing with this version.

If your system has a hard drive, make sure your data disk is in drive A:

If your system has two floppy drives, make sure your data disk is in drive B:

- a. Select 'Save As' from the 'File' menu.

The following window appears on the screen

Save as File	
File Name	<input type="text"/>
OK	Cancel

- b. Select the empty file box.

It will be replaced by

File Name	Cancel	OK
-----------	--------	----

- c. Begin typing and the File box will accept the input.

For a two floppy system type (substitute A for B if using a hard drive)

b: filename.1

where filename is your name (no spaces or periods).

d. When done select 'OK' at the end of the file name box.

e. Select 'OK' at the bottom left of the window. The file will be saved to drive B: (or to drive A: for a hard drive system).

This concludes this activity.

Quitting the Program

a. Select 'Quit' from the 'File' menu

b. Ignore the message that appears at the bottom of the screen

c. Remove all disks from the computer.

d. Pass the program disk and your data disk to the instructor.

Turn off all equipment.

Technology Education:

305

With Specific Applications in Industrial Technology

Information Communications Technology

Computer Assisted Drafting

Technology Learning Activity 2

Leon Cooper

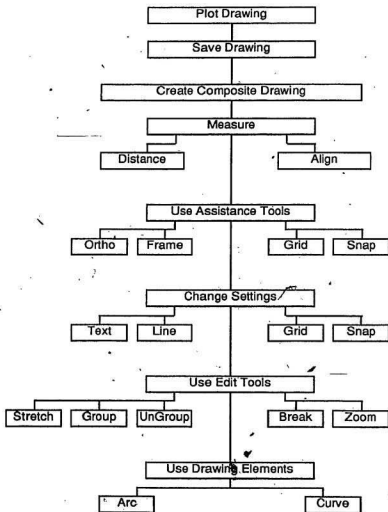

General Objective

Upon completion of this activity the student will be able to create, edit, and plot composite CAD designs.

Specific Objectives

Given the equipment and material listed below, the student will complete the following activities in an eight hour time limit.

1. Use the drawing elements Arc, and Curve.
2. Use the edit tools Stretch, Group, Ungroup, Break, Zoom.
3. Change the settings for Grid, Line Type, Snap, and Text.
4. Use the drawing assist features Ortho, Frame, Grid, and Snap.
5. Use the measure tools Distance and Align Dimension.
6. Create a composite drawing using the skills learned in TLA 1 and in this activity.
7. Save the Drawing.
8. Plot the drawing.

Equipment Required

MS-DOS Computer with 640k memory and a Math Coprocessor
CAD Program AutoSketch
Mouse (Logitech Bus Mouse or Microsoft Mouse)

Instructional Materials Supplied

Computer Assisted Drafting Technology Learning Activity 1 instructional package.

Quick Reference Guide for AutoSketch
Data storage Disk for AutoSketch

Review

Menus and Mice

The program uses a mouse as an input device. Moving the mouse around on the desk moves the pointer on the screen. The mouse has three buttons, but the center button is not used by this program. Both the outside buttons have the same effect. Operations are performed with the mouse by moving the pointer on the screen and clicking and releasing the mouse.

This program is menu driven. That means all operations are selected from a menu. The main menu items are visible across the top of the screen.

Menu selections are made by moving the pointer to the top of the screen on the desired option and pressing the button once. The list of items available under that option drops down beneath the selected option. Move the pointer to the desired item and click again. The selection will be loaded into the computer.

There is a status line across the bottom of the screen. AutoSketch displays information or makes requests below this line when you are expected to enter information into the computer. The first word displayed is the name of the operation you are performing (ie Line if you are drawing lines). The remainder of the words ask for input from the user.

Drawing Elements

Drawing elements are the basic components of a drawing.

Drawing Elements are used by the computer as mathematical entities, and each one is assigned a location, dimensions, and other properties. If you 'blow up' or zoom in on a line, for example, it does not get any thicker on the screen.

TLA 1 covered the Drawing Elements Line, Box, Circle, Polygon, and Text.

Composite Drawings are composed of two or more Drawing Elements.

Drawings may be changed or edited. Editing tools covered in TLA 1 were Move, Copy, Rotate, Erase, and Undo/Redo.

Drawings may be saved to a floppy disk for future use.

General Notes

This activity will last up to 8 hours and it is not likely that it will be completed in one sitting. The activity is divided into a number of sections.

It may be necessary to take a break in the middle of a section on creating a composite drawing. Make sure the composite drawing is saved before quitting the session.

It is a good idea to save the composite drawing every fifteen or twenty minutes. If there is a problem, then only the last fifteen minutes of work will be lost.

The plotter is used with this activity after a composite drawing is completed. It is not necessary to have it connected to the computer until that time.

Procedure

Loading the Program.

1. COMPUTER WITH HARD DRIVE.

a. Turn on computer.

b. When the prompt

C > appears

type the following:

cd sketch

The prompt

C> \sketch >

will appear on the screen.

c. type

sketch

Press the Return Key and the program will load.

2. COMPUTER WITH 2 FLOPPY DRIVES.

a. Insert MS-DOS disk into drive A (top drive).

b. Turn on computer. The computer will proceed to load the operating system

c. The prompt

A >

will appear on the screen.

d. Remove the MS-DOS disk and

insert the AutoSketch program disk into drive A
and

insert the Data disk (drawing storage disk) into drive B.

e. Type

sketch

Press the Return Key and the program will load and run.

Using Drawing Elements

Drawing Element: Arc (portion of a circle)

a. Select 'Draw' and 'Arc'. The status line will show

Arc Start point:

The point being requested is the starting point of the arc

b. Move the pointer to a starting location and click.

The status line will show

Arc Point on arc:

c. Move the pointer to a new location.

A line rubberbands with the pointer. The line end at the pointer is a point on the arc.

d. When the desired point on the arc is reached, click the button.

The status line shows

Arc End point:

e. Move the pointer to the desired endpoint and click the button.

The arc will be drawn and the status line will return to

Arc Start point:

ready to draw another arc.

- f. Draw several arcs and then clear the screen.

Reminder: Select 'File' 'New' and then
'Discard' from the screen prompt.

Drawing Element: Curve (draws a curved line)

Select a series of control points on the screen. The computer connects the points in the order that you create them. When you are done it draws a smooth curve that averages the distance between the points.

- a. Select 'Curve' from the 'Draw' menu. The status line will show

Curve First point:

requesting the first point on the curve.

- b. Select the first point. The status line will show

Curve To point:

requesting the second point.

- c. Select a second point.

A rubberband line will appear as the pointer is moved.

The status line will show

Curve To point:

requesting a second point.

- d. Repeat several times.

To end the curve:

click twice on the last point as it is created or
return to the first point and click.

- e. Clear the screen.

Special Note: To erase or move a curve, one of the control points on the curve must first be selected or a box must be drawn outside all the points used to create the curve.

Use Frame to Edit Curves
These control points can be made visible at any time by selecting 'Frame' from the 'Assist' menu.

To turn off Frame, select it again.

Editing Drawings

Edit Function: Stretch (make a portion of the drawing bigger or smaller)

To stretch an object at least part of it must be surrounded by a box. If an object is completely surrounded 'Stretch' will behave like the 'Move' function.

If only part of the object is surrounded that part will be stretched and parts not surrounded will remain where they are.

Create Simple Drawing

- a. Use several drawing elements to create this composite drawing.



Stretch the Drawing

b. Select 'Stretch' from the 'Change' menu

The status line will show

Stretch First corner:

asking for a corner of the box that will hold the parts to be stretched.

c. Select a point in this position.



The status line will show

Stretch Crosses/window corner:

requesting the box be drawn to contain the parts.

d. Move the pointer to this position and a dotted box will follow it.

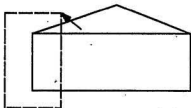

Select the point.

The status line will show

Stretch Stretch base:

asking for a "handle" on the object to move it with.

- e. Select this point

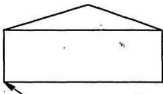

The pointer attaches to the object at that location and as the pointer is moved, the object is stretched.

- f. Move the pointer to a new location, and click the button.
g. Perform several stretch operations and clear the screen.

Edit Function: Group (turns several drawing elements into a single object)

Drawing Elements are grouped by surrounding them with a box. The outline turns into dotted lines. It turns into solid lines again when a new operation is started.

Grouped elements may be edited as a single object.

Create a Simple Drawing

- a. Use the drawing elements to create a composite drawing.

Use at least four elements...

- b. Use 'Mové' to rearrange the elements.

Notice that they move independently of one another.

- c. Select 'Group' from the 'Change' menu. The status line will read

Group Select object

requesting the first corner of the box that will enclose the elements to be grouped.

- d. Select a point below and to the left of all the elements of the drawing.

The status line will show

Group Crosses/Window corner

requesting the opposite corner of the box to enclose the elements

- e. Move the pointer to enclose the elements in a box. Click the button.

The status line will show

Group Select object

indicating that it is ready to group another set of elements.

Notice that the drawing is dotted. Selecting another function will make the drawing solid again.

Edit the Grouped Object.

- f. Perform the following editing operations on the grouped object.

1. Move
2. Rotate
3. Stretch
4. Copy

- g. Do not clear the screen. Proceed to the next function.

Edit Function: Ungroup

Ungroup is the opposite of Group. It works on any set of elements that have been grouped.

Ungrouping works by selecting a point on the object. The elements are then ungrouped.

Alternately, a box may be drawn around the object. The steps are then the same as for grouping.

- a. Select 'Ungroup' from the 'Change' menu. the status line will show

Ungroup Select object:

requesting a point on any edge of the object.

- b. Select a point on the object. The object will be ungrouped

The screen will show

Ungroup Select object

indicating that it is ready to ungroup another object

- c. Perform several editing functions (move, rotate) on the elements.

Notice that they are no longer attached to each other but move independently.

- d. Clear the screen.

Zoom the Drawing (enlarge/reduce screen view)

Zoom tools are in the 'View' menu.

Zoom works like a camera lens.

Zooming in makes the drawing appear larger, and shows a smaller area of the drawing on

the screen.

Zooming out makes the drawing appear smaller, and puts a larger area of the drawing on the screen.

There are several Zoom features. This exercise will use the following:

1. Last View
2. Zoom X
3. Zoom box
4. Zoom limits
5. Zoom full
6. Pan

Last View

Last view restores the view that was on the screen prior to the current one. There is no status line activity.

Zoom X

Zoom X magnifies the view by the value of X.

Numbers 0 to 1 reduce the view.

Numbers greater than 1 magnify the view.

The center of the screen remains the center of the new screen after Zoom X

Zoom Box

This feature requires a box to be drawn on the screen. The drawing area inside the box will be magnified to fill the screen.

This feature requires extra input from the user.

- a. Select 'Zoom box' from the 'View' menu. The status line will show

Zoom box First corner:

requesting the location of the first corner.

Note that the first word in the status line will be the function (if any) that

was active before selecting Zoom box.
After zooming, the status line will only
contain the name of the active function.

b. Select the first corner. The status line will
show

Zoom box Second corner:

requesting the second corner

c. Drag the pointer to enclose the section to be
zoomed. Click the button.

The status line will show the name of the active
function. To Zoom again it must be selected a
second time.

Zoom Limits

This feature creates a view that includes the
entire drawing area. It is set by the page
size of the drawing.

The startup page size is shown in the
'Limits' selection of the 'Settings' menu.

These can be changed at any time by selecting
'Limits' and typing in the new page size.

Zoom Full

This feature creates a view that fills the
screen with the entire drawing.

Pan (move around on the drawing)

Panning on the drawing is used when the
drawing view is larger than the screen.

In effect, the screen can be considered a
window onto the drawing. Panning moves the
window around over the drawing to change the
portion that is visible.

Panning does not change the magnification of
the drawing.

a. Select 'Pan' from the 'View' menu. The Status line will show.

Pan Pan reference:

requesting a reference point on the drawing.

b. Select a referenc point. The status line will show.

Pan Pan destination:

requesting a destination point.

c. Move the pointer to a new location and select a new point.

Notice the rubberbanding line to the new point.

The drawing will be shifted to the new location. The point on the drawing that was selected as a reference point will be moved to the destination point.

Pan must be selected each time it is used.

Practice each of the view selections until you are comfortable with them.

Clear the screen

Edit Function: Break (cut out a section)

Break is used to remove sections from drawing elements.

It will not work on grouped objects.

It will work on arcs, boxes, circles, polygons, and curves.

Break requires two points, the start of the break, and the end of the break.

If an end point is selected past the end of the element, the end section will be removed.

a. Select 'Break' from the 'Changes' menu. The status line will show

Break Select object:

requesting selection of the element that you wish to cut a piece from.

b. Select an object by clicking on an edge.

The status line will show

Break First break point:

requesting the start of the break.

c. Select the first break point.

The status line will show

Break Second break point:

requesting the end of the break.

d. Select a second point on the element.

The selected section of the element will be cut out.

The status line will show

Break Select object:

indicating that it is ready to break a piece out of another drawing element.

Drawing Aids

AutoSketch supplies a number of aids to drawing.

These drawing aids come under three menu selections.
The aids that will be used in this activity are:

1. Assist
Ortho
Frame
Grid
Snap.
2. Settings
Grid
Limits
Line Type
Snap
Text.
3. Measure
Distance
Align Dimension
Horizontal Dimension
Vertical Dimension.

Using Drawing Aids

* Assist Menu:

Ortho

'Ortho' is short for orthographic drawing.

It forces lines to be either horizontal or vertical.

When selected, 'Ortho' stays on until selected again.

Using Ortho

a. Select 'Ortho' from the 'Assist' menu.

b. Use the drawing elements, Line, Box, Curve, etc.

Observe the effect that 'Ortho' has.

c. Select 'Ortho' again to turn it off.

Frame

'Frame' is used to show the location of the control points when drawing curves.

When 'Frame' is used it connects each control point to the next one with a line as the points are selected.

'Frame' may be turned on after the curve is drawn, and it will still show all the control points and connecting lines.

Frame may be turned off by selecting it again.

This feature is useful when using the editing functions on curves.

To edit a curve, select a control point or draw a box around the entire curve and set of control points.

Using Frame

- a. Select 'Frame' from the 'Assist' menu.
- b. Select 'Curve' from the 'Draw' menu.
- c. Draw a series of curves.

The control points and the lines connecting them will remain on the screen after the curve is completed.

- d. Use these editing functions on the curves.
 - 'Move'
 - 'Rotate'
 - 'Copy'
 - 'Erase'

Grid

Selecting 'Grid' turns on a grid of dots on the screen.

'Grid' is a useful tool for aligning drawings.

'Grid' spacing is set using the 'Settings' menu.

'Grid' is often used in conjunction with 'Snap'

Using Grid

- a. Select 'Grid' from the 'Assist' menu.

A grid of dots will appear on the screen.

Snap

'Snap' forces the pointer to snap to the nearest snap point.

The snap points will be the same as the grid points if each has the same spacing.

Using Snap

- a. Select 'Snap' from the 'Assist' menu.

- b. Draw a line, arc, circle, polygon, etc.

Notice that all points selected are on the grid points.

- c. Turn off all 'Assist' functions.

Settings Menu:

Grid

Grid Setting is used to change the size of the grid.

Spacing is set in fractions or multiples of units.

The default setting is one unit on the X-axis and one unit on the Y-axis. A setting of 0.5 will give a grid with twice as many dots on the screen as the default.

If the X spacing is changed, the Y spacing changes automatically to the same setting as

the X.

The Y spacing may be changed to a number different than the X spacing if desired.

Setting the Grid Spacing

- a. Select 'Grid' from the 'Settings' menu.

This window will appear on the screen

Grid

X Spacing	1
Y Spacing	1
Grid	On
OK	Cancel

- b. Select

1

on the X Spacing line

The line will change to

X Spacing	1	Cancel	OK
-----------	---	--------	----

- c. Type

. 0.5

and press the return key or select OK on the X Spacing line

The line will return to its former size and the spacing will now be 0.5

The Y spacing line will also have 0.5.

The Y Spacing may be changed, independently of the X Spacing.

To change Y Spacing, repeat the same steps on the Y Spacing line as were done on the X

spacing line.

The X Spacing will not change.

Note: if large numbers are selected, the grid may be so large that there are no dots on the screen.

- c. When done with the settings, select OK from the box.
- d. Experiment with a number of grid settings.

Line Type

The line type selected will be used to draw all objects (dimensions and text are always solid) until another type is selected.

Setting Line Type

- a. Select 'Line Type' from the 'Settings' menu.

This window will appear on the screen

Drawing Line Type

Solid
 Dashed
 Hidden
 Centre
 Phantom
 Dot
 Dashdot
 Border
 Divide
 Dots

Scale factor 1

OK Cancel

Notice that there is a checkmark in the 'Solid' box. this is the default line type.

- b. Select 'Dashed' and then click OK
- c. Select any drawing tool (line, 'arc, etc.) and draw a series of objects.

- e. Change to a new line type and repeat.
- d. Use all the line types.

Snap

'Snap' spacing can be set independently of the grid spacing.

If it is the same as the grid spacing, then points will snap to the grid.

If snap spacing is different than grid spacing, points will snap to the invisible snap points, and ignore the grid points.

The default spacing is 1 unit for both X and Y spacing.

Snap is set exactly the same way as grid spacing.

Setting Snap

- a. Select 'Snap' from the 'Settings' menu.
- b. Set 'Snap' to the same settings as you used in 'Grid'

Text

Text attributes that may be set are:

1. Height of letters (may be any positive value)
2. Angle of the text (any angle may be used for the baseline angle)
3. Width of the text (normal is 1, less than 1 gives narrower text, greater than 1 gives wider text)
4. Obliquing angle (letter slope - a positive angle slopes to the right, a negative angle slopes to the left - use numbers from -30 to +30)

Setting Text Drawing Modes

- a. Select 'Text' from the 'Settings' menu

This window will appear on the screen

Text Drawing Modes

Height	0.3
Angle	0
Width factor	1
Obliquing angle	0

OK Cancel

- b. Make the following settings:

height	1
Angle	30
Width Factor	1.3
Obliquing angle	20

- c. Select OK

- d. Select 'Draw' and 'Text'

- e. Enter this text:

"I'm so good at this!"

- f. Experiment with two or three text settings and type some text after each setting.

Measure Menu:

Distance

Distance is used to measure the distance between any two points on the screen.

Using Distance

- a. Select 'Distance' from the 'Measure' menu

The status line will show

Distance From point:

c. Select the point you wish to measure from.

The status line will show

Distance To point:

d. Select the point you are measuring to.

A rubberband line will follow the pointer.

When the selection is made a box like this one will appear on the screen

Distance is 5.23451

OK

e. Select OK

f. Measure several objects.

Align Dimension

Align dimension is used to place dimension lines at any location or angle on the drawing.

The dimension is measured automatically and entered as part of the dimension.

The text for the dimension is the same size as the current 'Text' Settings'.

There are two stages to placing a dimension on the drawing:

1. Measure the distance along the edge of the object.
2. Set the dimension offset distance from the object

Placing Aligned Dimensions

- a. Select 'Align Dimension' from the 'Measure' menu

The status line will show

Aligned dimension Points to dimension:

- b. Select the point you wish to measure from.

The status line will show

Aligned dimension To point:

A rubberband line will follow the pointer.

- c. Select the endpoint of the dimension.

The status line will show

Aligned dimension Dimension line location:

- d. Move the pointer to the location that you wish the dimension line to be placed.

Click the button.

The dimension line will be placed parallel to the line that was measured.

- e. Place four or five dimension lines at various angles and distances.

Create a Drawing

Use the Drawing Elements and Editing tools you have learned thus far to duplicate the following drawing.

Don't forget to use the drawing aids, the Zoom features, and the editing tools.

Set Grid and Snap X-Y spacing at 1

Set text height at 0.3, and width factor at 1.

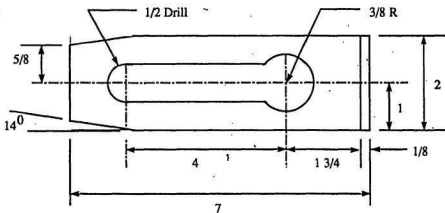

Save the Drawing

Select 'Save as' from the 'File' menu.

Follow the same procedure as in TLA 1.

AT THIS POINT IT IS NECESSARY TO CONNECT THE PLOTTER TO THE COMPUTER. THE COMPUTER MUST BE OFF TO DO THIS.

Quit the Program

a. Select 'Quit' from the 'File' menu.

Connecting the Plotter

- a. Make sure all power is off.
- b. Connect the parallel cable to the parallel port on the plotter, and to the parallel port on the back of the computer.
- c. Plug in plotter power supply.
- d. Place paper between marks on plotter.

Be careful not to scratch black surface.

- e. Check to see that the PaperHold switch is off on the plotter (Top right corner).
 - f. Move the plotter pen holder to the lower left corner of the plotter.
 - g. Place pens in pen holders (check with instructor for procedure)
 - h. When ready, check with instructor before proceeding.
- If everything is approved procede to the next stage.

Reboot the Computer

- a. Refer to the startup instructions at the beginning of the activity. Boot the system.
- b. Load the drawing into the computer.
- c. Check to see that the plot head is in the lower left corner (home position)
Turn on the plotter.
- d. Press the paper hold switch.

Plot the Drawing

Plotting a drawing requires two steps.

1. Selecting the plot area
2. Plotting the drawing.

Selecting the Plot Area

The plot area designates which portion of the drawing will be plotted.

Selecting the plot area places a rectangle on the screen enclosing the plot area.

The plot area may be scaled. If the drawing represents an object 20 meters long, the the drawing will be 20 units long. The paper may be 10 cm. long. In this case the scale would be 1 drawing unit for .5 plotting units in order to get the drawing on the paper.

- a. Select 'Plot area' from the 'Files' menu. The window on the next page will appear on the screen.

A (11 X 8.5in.)		A4 (297 X 210 mm)	
B (17 X 11in.)		A3 (420 X 297 mm)	
C (22 X 17in.)		A2 (594 X 420 mm)	
D (34 X 22in.)		A1 (841 X 594 mm)	
E (44 X 34in.)		A0 (1189 X 841 MM)	

Inches		Millimeters	
--------	--	-------------	--

X Plot Size	10.5	Y Plot Size	7.74
-------------	------	-------------	------

Scaling

Drawing Units	=	Plotting Units
1	=	1

Rotate by 90 Degrees	Off
----------------------	-----

Create Plot Box	ON	Create Clip Box	Off
-----------------	----	-----------------	-----

OK	Cancel
----	--------

The X Plot Size and the Y Plot Size will be slightly smaller than the paper size. This prevents the plotter from drawing outside the paper.

The scaling should be set at 1 Drawing unit to 1 Plotting unit.

Rotate should be Off

Create Plot Box should be On.

a. Select OK when done.

The screen will show a box surrounding the drawing. If it is not visible select 'Zoom Limits' or 'Zoom Full' and it will be visible.

If the drawing has parts outside the Plot Box, use the editing tools Move, or Stretch to relocate or resize the Plot Box.

Plot the Drawing

If everything is ready, plot the drawing.

- a. Select 'Plot' from the 'File' menu.

When the plot is complete, shut down the system.

ShutDown Procedure.

- a. Turn off a equipment.
- b. Remove disks from computer.
- c. Remove paper from plotter.
- d. Recap plotter pens and place in holder.
- e. Unplug plotter power supply.
- f. Unplug parallel cable from plotter to computer.
- g. Place cover on plotter.
- h. Turn in plot and diskettes to instructor.

Technology Education:

339

With Specific Applications in Industrial Technology

Materials Technology:
Manufacturing Systems

Process Control/Robotics

Technology Learning Activity 1

Leon Cooper

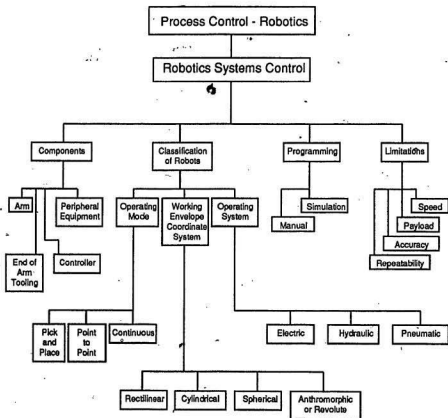

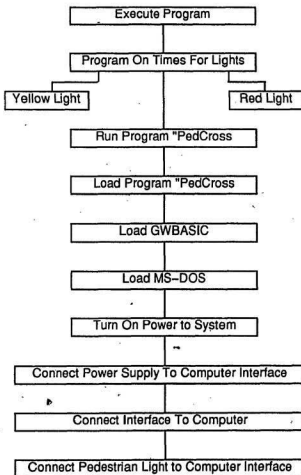

General Objective

The student will gain practical experience with computer process control of machines by operating a programmable pedestrian light.

Specific Objectives

Given the equipment and instructional materials listed below, the students will achieve the following objectives within a one hour time limit;

1. Connect the fischertechnik traffic light to the interface.
2. Connect the power supply to the interface.
3. Connect the interface to the computer.
4. Turn on the computer, load MS-DOS, load GWBASIC, load and run the Basic program PEDCROSS.
5. Program the 'on' time for the yellow and for the red traffic lights.
6. Operate the pedestrian light by executing the program and by pressing the pedestrian switch.
7. Demonstrate an understanding of the process by correctly answering the questions contained in the procedure sheets.

Equipment Supplied

- 1 IBM PC
- 1 fischertechnik Computing kit
- 1 fischertechnik IBM interface
- 1 power supply (fischertechnik)
- MS-DOS, GWBASIC
- Program disk.

Robotics: Process Control
Technology Learning Activity 1

343

Instructional Materials Supplied

Instruction package including:
Procedure sheets.
Program disk.
fischartechnik Computing Kit and manual.

Computer Process Control

Process control is the use of a computer, or digital logic device, control the operation of a piece of mechanical equipment.

The equipment being controlled can have an electric, a hydraulic, or a pneumatic power supply.

An interface is placed between the computer and the machine. The interface provides several services to the computer and the machine.

1. It allows two kinds of input (signals in) into the computer from the machine
 - a. digital, or on/off (the type that the computer likes)
 - b. analog, or continuously variable (which it converts into digital)
2. It allows two kinds of output (signals out) from the computer to the machine
 - a. digital to the machine
 - b. digital which it changes to analog for the machine

Feedback is the process of providing signals back to the computer so that it can monitor progress and make changes to the operation of the machine.

Systems without feedback are called open loop systems.

Systems with feedback are called closed loop systems.

The pedestrian light provides a feedback loop to the computer. The feedback is activated when the pedestrian button is pressed. This signals the computer to interrupt the green light which is normally on. The lights then cycle through a preset time sequence.

Procedure

CAUTION: DO NOT TURN ON POWER TO THE COMPUTER OR ANY DEVICES BEFORE COMPLETING THE FOLLOWING STEPS.

A. Set up the Equipment

1. The pedestrian light has already been assembled.
2. Trace the assembly procedure for the light by using the wiring diagram and the sequential assembly diagrams in the fischertechnik computing kit manual.

3. Locate each of the following:

lights M1, M2, and M3

switch E8

4. Plug the flat cable from the light into the interface.

5. Plug the cable from the power supply into the interface.

red = positive
green = negative

Use either of the (+, -) input pairs on the interface.

6. Plug the interface cable into the parallel port on the computer.

7. Plug the power supply into the power bar. Do not turn on yet.

Answer the following questions:

1. What is the purpose of switch E8?
2. What is the purpose of M1, M2, and M3?

Check all connections.

IF ALL CONNECTIONS ARE OK, CHECK WITH INSTRUCTOR, AND THEN PROCEED TO THE NEXT STAGE.

Operation of the Pedestrian Light

Note: instructions are in lowercase, enter the words in CAPITALS into the computer.

This activity uses the program PEDCROSS.

Booting (starting) the Computer

1. Place the

MS_DOS

disk in drive A: (Top drive in the computer)

Turn the powerbar on.

2. When the computer gives the prompt

A >

place the

fishtek

program disk in drive A:

Load Basic

1. Type

GWBASIC (press return key)

Basic will load into the computer and the basic prompt

ok

will appear on the screen.

2. Type

RUN "A:PEDCROSS (press return key)

This will load the program PEDCROSS from drive A, and then run it.

This will appear on the screen

fischertechnik
computing

Adjust screen colours? (y/n)

Using the Program PEDCROSS

1. Learning the program:

a. Type

N.

in response to the question

Adjust screen colors?"

since this is a monochrome monitor.

The screen will change to

fischertechnik
computing

Pedestrian crossing

Time of Yellow-Period (Sec) ?

b. Type in the number (between 1 and 10) of seconds for the yellow warning traffic light to be on, and then press the return key.

The following is added to the screen

Time of Red-Yellow Period (Sec) ?

c. Specify the number of seconds for the red traffic light to be on, and then press return.

The following is added to the screen

- 1.Green-Period
- 2.Yellow-Period
- 3.Red-Period

Traffic light ready ? (y)

The computer will only accept a press of the 'Y' key on the keyboard.

d. Make sure that everything is ok and then press

Y

The screen changes to add this to the bottom of the screen

Ctrl-Num Lock: Pause
Any other key: Continue
Ctrl-Break: End of Program

and the computer will show the Green Period active on the screen.

At the same time, the Green traffic light will come on and stay on.

Provide Feedback to the Computer

- a. Activate the pedestrian crossing by pressing the switch (E8) on the traffic light.

Notice that the computer screen will cycle through the

Yellow-Period

and then the

Red-Period

and then return to

Green-Period.

The traffic light will cycle through the same colours at the same time.

Reprogram the Computer

Stop the Program

The program can be stopped by pressing the Ctrl and Break keys simultaneously.

a. Break out of (end) the program. Press

Ctrl-Break

b. Press the return key a few times to move down to a clear space on the screen.

Run the Program Again

a. Type

Run (press return)

and reprogram the light periods.

b. End the program and run it several times.

Use different time periods each time the program is run.

Observe the effects that different times have on execution of the program.

In particular look at the time delay from the time the switch E8 is pressed until the light turns yellow, then red, and then green.

Answer the following questions:

1. Why is the green light normally on?
2. In a real traffic situation, what reasons would there be for programming different delays (yellow and red) at different times of the day?

3. What effect would speed limits have on the programmed delay choices?
4. What industrial activities can you think of where programmed delays can be used?

Ending the Activity

When you are finished the activity

- a. Remove disks from the computer and return to storage boxes.
- b. Turn off equipment.
- c. Unplug fischertechnik equipment from the computer and from each other.
- e. Finish answering questions and hand in to instructor.

351

Technology Education:

With Specific Applications in Industrial Technology

Materials Technology:
Manufacturing Systems

Process Control/Robotics

Technology Learning Activity 2

Leon Cooper

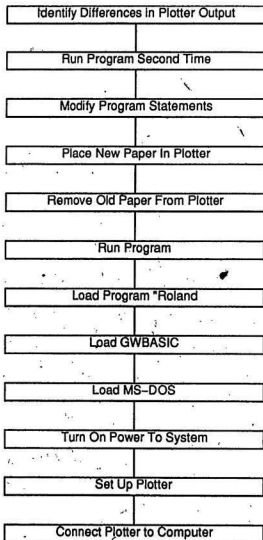

Rectilinear Coordinate Robot
Technology Learning Activity 2

353

General Objective

Students will program and operate a rectilinear robot system.

Specific Objectives

Given the equipment and supplies listed below, the students will successfully perform the following operations within a one hour time limit.

1. Connect the plotter to the computer.
2. Set up plotter
3. Turn on all equipment.
4. Load MS-DOS, and GWBASIC.
5. Load and Run the program "Roland".
6. Remove the plotter output from the plotter and place new paper in plotter.
6. Modify some of the program statements and save the new program.
7. Run the program again and identify the differences in plotter output.

Equipment Needed

MS-DOS computer
GWBASIC
Program disk containing basic program "Roland"
Roland DXY 980 plotter and parallel cable
Plotter paper

Instructional Materials Supplied

Technology Learning Activity 2 including instructions

Robotic System

Robots are computer controlled machines with a movable arm that operate in three dimensional space.

Robots have four basic parts:

1. the arm
2. the processes controller (interface to the computer)
3. end of arm tooling (spray gun, welder, etc.)
4. peripheral equipment (conveyor belts, tools)

Robots may be classified three ways:

1. by operating mode
 - i. pick and place (move something from one point to another repeatedly)
 - ii. point to point (move through a series of points)
 - iii. continuous operation (move through a continuous path)
2. by working envelop coordinate system (working envelope is the three dimensional space that the robot arm can reach into)
 - i. Rectilinear

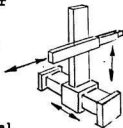

ii. cylindrical

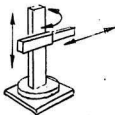

iii. Spherical

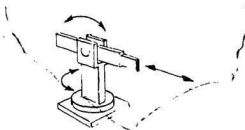

iv. Anthropomorphic



3. by operating system
 - i. electric power
 - ii. hydraulic power
 - iii. pneumatic power.

Robots may be programmed one of three ways:

1. Manually, by taking the robot out of production and programming it by moving it through a series of steps (TLA 3).
2. Manually, by programming it on the production line.
3. By programming a computer simulation of the robot. The program is loaded into the robot at a later time.

Robots have these limitations:

1. There is a limited payload. Some machines can lift a few kilos while others can lift thousands of kilos.
2. Accuracy of operation refers to the smallest incremental move that the robot can make.
3. Repeatability is related to accuracy, but it refers to the ability of a robot to return to exactly the same place over and over.
4. Speed of operation is important for some operations.

Rectilinear Coordinate System

This activity uses a rectilinear coordinate system. This is a modified closed loop system.

The plot head must be manually positioned to a 'home' position before the plotter is turned on. This home position is the reference position for all other operations on the plotter.

If the plotter is turned on with the plot head in another position, all operations will work incorrectly.

The plot head moves on the x-axis and the y-axis. Z-axis movement is limited to the up/down motion of the print head.

X-Y motion is provided by stepper motors. Each digital pulse from the computer turns a particular motor a precise fraction of a degree. Each pulse corresponds to a fractional movement along the X or Y axes.

Pen up/down is controlled by an electromagnet. The computer provides a continuous voltage to the magnet to keep the pen down. When the voltage is off, a spring returns the pen to the up position.

Feedback is provided to the computer by keeping track of the number and direction of pulses to the motors. This is obviously relative to the plothead start position when the plotter is turned on. Hence the need for a 'home' position.

This continuous path, rectilinear device has an

electric power system, a limited payload, an accuracy of 1/1000 inch, and a repeatability of 5/1000 inch, and is high speed. The end of arm tooling is a pen holder.

Getting Started

MAKE SURE POWER IS OFF TO ALL DEVICES BEFORE BEGINNING.

Connect Equipment

1. Connect the Roland plotter to the computer using the parallel cable.

Load Operating System

2. Insert

MS-DOS disk

into drive A:

3. Turn on power bar.

After the system starts up, the screen will show

A >

4. Remove the disk and replace with

fishtek disk

Load Basic

5. Type

GWBASIC (press return key)

The screen will show the basic prompt

OK

Setup the Plotter

1. Make sure PaperHold switch on the top right corner of the plotter is off (up).

2. Turn plotter on.

3. Place a sheet of paper (supplied) inside the taped outline on the plotter.

Be careful not to scratch the black surface.

4. Turn PaperHold switch on (down)
5. Check with instructor on proper procedure for placing pens in plotter.

Operating the System

Check with instructor before proceeding with this step.

Load and Run the Program

1. Type

Run "Roland" (press Return)

This will load and run the basic program 'Roland'.

The plotter will begin operating and will draw a series of diagrams.

When the plot is complete, the screen will show the basic prompt

OK

Remove Plot from Plotter

1. Turn off PaperHold switch and after a minute or so, remove paper from plotter.

Refer to the plot when performing the next section.

Explanation of the Program

The program listing (in the Appendix) is composed of several logical sections:

Drawing the X-Y axis

Title: Coordinate

line # 200 - 250

Purpose: draws the x and y axes with divisions.

Drawing the line chart

Title: Line Chart

line # 300 - 430

Purpose: Draws the dotted line chart

Gets its y-positions for lines from the data statement.

in line # 10010

Drawing the bar chart

Title: Bar Chart

line # 500 - 590

Purpose: Draws bar chart in same location as line chart. Bar heights come from same data statement.

Printing the month names

Title: Character

line # 600 - 690

data statement line # 10020

Purpose: Print the month names beneath the bars on the bar chart. Names come from data statement line # 10020

Rotating the Characters

Title: Character Rotation

line # 700 - 780

Purpose: Rotate characters 90 degrees and print bar heights along y-axis of chart.

Placing the chart title

Title: Character Size

line # 800 - 850

Purpose: Enlarge the character size and draw the bar chart title.

Drawing the pie chart circles

Title: Circle 1

Circle 2

Circle 3

line # 900 - 980

Purpose: Draw three circles with radii 50 mm., 15 mm., and 20 mm.

Drawing the pie segments on the pie chart

Title: Pie Chart

line # 1000 - 1050

Purpose: Divide the two outer circles into twelve segments.

Drawing the month indicator lines on the pie chart

Title: Indication Line

line # 1200 - 1320

data line # 10000 and 10010

Purpose: Draw a line to each segment on the pie graph, and label each.

Modifying the Program

In order to make changes to the program, the appropriate lines must be typed into the computer again.

The changed program must then be saved under a different name.

Change data statement.

The heights of the line chart and the bar chart are both determined by the values in the data statement in line # 10010.

The basic prompt OK should still be on the screen.

a. Type

```
10010 DATA 450, 600, 100, 750, 250, 900, 600, 400,  
900, 200
```

Make sure there is a coma after every number since this is how the computer distinguishes between the numbers.

Change number of pie segments

The number of segments in the pie chart is determined by line # 1020

```
1020 A = 100/12
```

where 100 means 100% and 12 means 12 segments. The remainder of the "Pie Chart" section calculates the percentage for each segment and draws the line at the correct location.

a. Type

```
1020 A = 100/24
```

Question: How many segments will this produce?

Save the New Program
THE PROGRAM MUST BE SAVED WITH A NEW NAME, OTHERWISE IT
WILL OVERWRITE THE PROGRAM ON THE DISK.

a. Type

Save "Roland.Name (press return)

where Name is your first name.

The program will be saved, and the basic prompt

OK will appear on the screen.

Plotting the new program
Plot the new program and compare it to the original
drawing. Compare the output to the data statements.

a. Put a new sheet in the plotter

b. Turn on PaperHold switch.

c. Type

Run

and the program will plot.

d. When done, turn off PaperHold switch on plotter.

e. Remove plot from plotter.

Ending the Session

To end the session:

a. Turn off power bar

b. Recap plotter pens

c. Cover plotter

d. Remove parallel cable from computer and plotter.

e. Replace computer disks in storage box.

f. Answer questions and turn in report.

Questions

1. What makes the pen move on the x-axis and on the y-axis?
2. How could the plotter be forced to draw a horizontal line for the 12 months of line graph data?
3. What effect would this have on the bar chart?
4. A circle of radius 50 mm. has a number of 500 entered (line # 910).
Write line # 910 for a 200 mm. circle?

Technology Education: 364
With Specific Applications in Industrial Technology

Materials Technology:
Manufacturing Systems

Process Control/Robotics

Technology Learning Activity 3

Leon Cooper

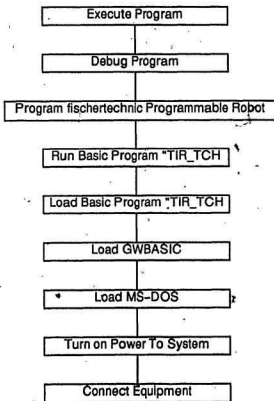

TEACHABLE ROBOT

General Objective:

The student will gain practical experience in operating a cylindrical coordinate robotic device.

Specific Objectives:

Given the equipment and instructional materials listed below, the students will perform the following activities within a two and one half hour time limit;

1. Program the fischertechnik robot to perform 'Pick and Place' operations.
2. Debug (fix problems in) the execution of the robot program.
3. Execute the robot program and have the robot successfully perform the operations.

Equipment Supplied

- 1 IBM PC
- 1 fischertechnik Computing kit and manual
- 1 fischertechnik IBM interface
- 1 power supply (fischertechnik)
- MS-DOS, GWBASIC
- Program disk.

Instructional Materials Supplied:

Instruction package including:

- Procedure sheets.
- Program disk.

Review

TLA 1

TLA 1 used the computer for simple process control of an external closed loop system (pedestrian light).

A Pedestrian switch on the light provided feedback to the computer.

The feedback altered the output of the program, which changed the status of the lights.

TLA 2

TLA 2 took process control one step further and used the computer to operate a plotter.

This closed loop rectilinear system obtained feedback from positioning devices within the plotter.

The computer calculated all 'x - y' positions for the plot pen relative to the "Home" position set at startup of the plotter.

Note that the plotter could be confused if the pen was not manually set to the correct home position before power up.

Thus the feedback was not foolproof.

Cylindrical Coordinates

The cylindrical coordinate system shown below has three axes of motion:

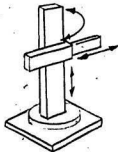

Circular around a vertical axis

Up/down on the vertical axis

In/out horizontally on a ray from the vertical axis.

If the end of the arm is run through a horizontal circle while being raised and lowered it will describe a cylinder, hence the name cylindrical coordinates. This cylinder is the work envelope.

Cylindrical Coordinate Robot Technology Learning Activity 3

368

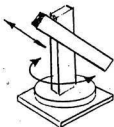

The teachable robot used in this activity has an modified cylindrical movement. The arm is not horizontal, but is set at 45 degrees. Lateral movement along the arm provides a horizontal and a vertical component. This, combined with the circular motion of the platform describes a conical work envelope.

The robot is taught by operating the motors using simple on off switches. When a desired location is reached, the computer is 'taught' the location by pressing an input switch. Smoother operation can be achieved with smaller steps. After the robot has been programmed, the computer can repeat the instructions and operate the robot.

User Input Switches

Switches E1 to E8 are used as follows:

E1	arm up
E2	arm down
E3	rotate left (CCW)
E4	rotate right (CW)
E5	magnet on
E6	magnet off
E7	teach (tell computer current location)
E8	switch control back to the computer

Computer Input Devices

The computer gets information on the position of the turntable (rotation) and arm (height) from variable resistors or potentiometers (pot).

There is a pot on each motor M1 and motor M2.

As the motor rotates the pot, the resistance of the pot changes, and therefore the voltage across the resistor changes.

The voltage change is an analog signal (continuously variable) and the interface changes

Cylindrical Coordinate Robot
Technology Learning Activity 3

369

it into a digital signal (on/off) for the computer. The signal provides the position readings for the robot.

Cylindrical Coordinate Robot
Technology Learning Activity 3

370

CAUTION: DO NOT TURN ON POWER TO THE COMPUTER OR ANY DEVICES BEFORE COMPLETING THE FOLLOWING STEPS.

A. Setup.

1. The teachable robot has already been assembled.
2. Trace the assembly procedure for the robot by using the wiring diagram and the sequential assembly diagrams from the manual, and referring to the labels on the robot.

Locate each of the following:

switches E1 to E8
motors M1 and M2
electromagnet (designated M3)
Potentiometers one and two.

3. Plug the flat cable from the robot into the interface.
4. Plug the cable from the power supply into the interface.

red = positive
green = negative
Use either of the (+, -) input pairs.
5. Plug the interface cable into the parallel port at the rear of the computer.
6. Plug the power supply into the power bar. Do not turn on yet.
7. Answer the following questions:
 1. What is the purpose of switches E1 to E8?
 2. What does M1 operate?
 3. What does M2 operate?
 4. What is the purpose of M3?
 5. What is the purpose of potentiometers one and two?
 6. What purpose do the lights serve?

8. Check all connections.

IF ALL CONNECTIONS ARE OK, CHECK WITH INSTRUCTOR, AND THEN PROCEED TO NEXT STAGE.

B. Operation of the Robot.

Note: instructions are in lowercase, enter the words in CAPITALS into the computer.

This activity uses the program Tir_Tch, which provides two types of operations or sub-programs:

- a. TEACH the robot a series of steps
- b. EXECUTE the program that the robot has been taught.

Boot (start) the Computer

Load DOS

1. Boot the computer using DOS.
2. Place the MS-Dos program disk in drive A
3. Turn on Power bar

Load Basic

4. Type

GWBASIC

and press the Enter key (Return)

Do this after typing to tell the computer to accept the information

The basic prompt "ok" will appear on the screen.

Load and Run the Program

5. Type

RUN "A:TIR_TCH

This will load the program Tir_Tch from drive A: and run it.

Cylindrical Coordinate Robot
Technology Learning Activity 3

372

The screen will show

Adjust screen colors? Y/N

Learning the program:

a. Type N in response to the question "Adjust screen colors?" (this is a monochrome system).

The screen will display this screen

fischertechnik
computing

Teach in Robot

Selection of Program

Teach mode

Execution mode

End of program

Space bar: Select program
Return: Start of program

The selected item will be highlighted

b. Hit the 'Return' key to accept the on screen choice of "Teach mode".

The computer displays

Nr. Height Rotation Magnet

Robot Ready? Y/N

c. Type Y in response to "Robot ready" on the screen.

Cylindrical Coordinate Robot
Technology Learning Activity 3

373

The computer displays

E1 = Arm up	E5 = Magnet on
E2 = Arm down	E6 = Magnet off
E3 = Body cw	E7 = Learn
E4 = Body ccw	E8 = Menu

Nr.	Height	Rotation	Magnet
0	245	267	off

Robot Ready? Y/N

Ctrl-Num Lock: Pause
Space bar: Continue
Ctrl-Break: End of program

Note that the numbers will be different on your screen.

Follow onscreen instructions to operate the program.

d. Practice using the switches E1 to E6 to operate the robot.

Follow the onscreen instructions and observe the feedback to the computer in the onscreen box.

The Rotation and Height numbers change as the robot is moved.

CAUTION: Do not exceed the machine limits by raising or lowering the arm too far, or by rotating the platform to put a strain on the wiring harness.

e. When ready

quit the program

by selecting

CTRL and Break keys simultaneously
and run the program again by typing

RUN

This will clear the computer's memory.

This is an important thing to do since the computer will remember all the steps that the robot made and will do things that are unanticipated.

The result could be damage to the device.

Teaching the robot

Make a Step

a. Press

E7 (learn)

This tells the computer the current location of the device

b. Step the robot through one motion

c. Press

E7 (learn)

Make Another Step

d. Move the robot to new location. Press E7 again.

Make Several Steps

e. Repeat several times.

Dont forget to press E7 after each move.
Use Rotation, arm Up/Down, and magnet On/Off.

f. Return to the menu (press E8), and select

Execution mode

REMINDER: Do not go back to TEACH mode without exiting the program - the accumulated steps can cause unexpected results and may break the mechanism.

Answer the following question:

1. Does the robot follow all the movements that were used in the teach stage (including mistakes) or does it go directly from the position of one learn input (E7) to the next learn input?

If necessary 'Execute' the program that the computer 'Learned' again and observe the action.

Planning robot operations

a. Plan a sequence of moves on paper.

The metal discs must be moved from one location to another in some of the moves.

b. Enter the moves into the robot and have the computer 'Learn' at appropriate positions along the path.

Hints

for curved movement, 'Teach' a number of points on the curve

for precise control observe the onscreen Height and Rotation numbers

the number of 'Teach' points may be greater than the number of steps that the robot executes, ie 'Teach' for each component of a movement, for magnet on/off, etc.

pauses can be created by pressing the learn switch several times in a row

Execute the Program

Return to Execution mode and observe the operation.

If the program does not execute properly, End the program

RUN

the program again and teach again.

Repeat until it works properly.

When the program is working satisfactorily, execute it several times, and record the Height and Rotation readings at the end of each execution.

Answer the following questions:

1. Which is the best procedure, planning the moves on paper first, or working them out as the robot is taught? Why?
2. Did the Height and Rotation readings for each execution agree? Can you explain this?
3. Do you think the program be made to repeat automatically? Why or why not?
4. What industrial applications can you think of for this type of programmable robots?

Ending the Activity

Make sure the power is off on all equipment, and all disks are removed from disk drives.

Place disks in holders provided.

Finish writing up the questions for the activity and pass to instructor.

Technology Education: 377
With Specific Applications in Industrial Technology

Information Communications Technology

Desktop Publishing

Technology Learning Activity 1

Leon Cooper

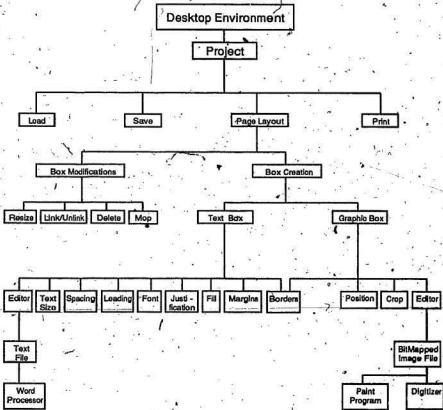

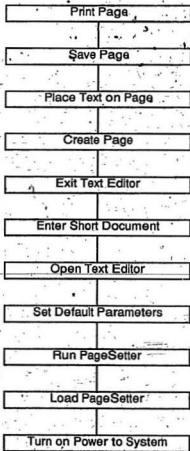

General Objective

Upon completion of this activity, the student will successfully create and print a simple page layout using a desktop publishing program.

Specific Objectives

The student will successfully complete this activity within a two hour time limit by accomplishing the following objectives:

1. Load the program PageSetter into the Amiga computer.
2. Set the default parameters for page creation.
3. Set the default parameters for box creation.
4. Set the default parameters for the desktop environment or artboard.
5. Open the Text Editor.
6. Type in a short document.
7. Exit the Text Editor
8. Create a page.
9. Place text on the page.
10. Save the page.
11. Print the page.

Equipment Supplied

- 1 Amiga computer
- 1 PageSetter program disk
- 1 program data disk
- 1 printer

Instructional Materials Supplied

Instruction Package including:
Description of PageSetter operation.
Instructions for completing the activity.

Desktop Publishing
Technology Learning Activity 1

381

Instructions

Note that if you are required to do something
the following prompt will appear:

Do This

When something will happen this prompt will be
on the page:

This Will Happen

Please read all information following the
prompt:

For Your Information - Please Read

since it contains information vital to
understanding the operation of the program.

Information: Please Read

The Pagesetter Program

Description of the Program

This program is used to create page layouts. Pages consist of text and graphic images or pictures. The program simulates a desktop. Pages can be placed on the desktop by 'creating' them. Text and images can be placed on the pages by creating 'boxes' on the pages, and then placing the text or graphics in them.

Global parameters can be set for the pages, so that each page created will be the same size, and have the same margins (nothing placed outside the margins will print when the page is printed).

Global parameters can be set for the boxes. Some of the box parameters are: the same kind and size of characters, the same frame around the box, the same text spacing or kerning (distance between characters and between words), and the same leading (distance between lines of text). Margins set for boxes alter the distance from the edge of the box to the text, and are therefore different from page margins. Text boxes may be set to have text aligned on the left margin, on the right margin, on both margins, or centered between the margins.

In addition a page or a box can be selected at any time and the parameters for that page or box changed.

Text boxes may be linked together so that text flows from one to the next automatically.

Graphic images may be moved around within a box and cropped by changing the size of the box so that only part of the picture shows through.

Boxes may be moved around on the page and off the page and placed onto the desktop or 'artboard'. From there they may be moved onto another page.

Pages may have one of three levels of magnification. The smallest shows the entire page at one time, medium shows about three quarters of the page, and high magnification shows about 1 sixteenth of a page. High magnification is the only one that allows all text sizes to be read.

There are a number of page layout aids. They are:

1. a grid for alignment
2. a grid snap which forces the top left corner of a box to go to grid intersections
3. a ruler to show dimensions in inches or picas
4. page margin outlines
5. box outlines to show the edges of boxes that have no visible frames and to show the currently 'active' box (the one being worked on).

Creating Text and Pictures

Text may be created three ways:

1. With a Quick text option for up to 99 characters
2. With the Text Editor
3. By using the Text Editor to bring in a text file created in another wordprocessing program.

Graphic images may be created two ways:

1. With the Graphic Editor
2. By using the Graphic Editor to import a picture from a painting program.

Input Devices

This program runs on an Amiga computer. It accepts input from the keyboard and from the mouse. The mouse (Diagram 1) has two buttons. The right button is always used for selecting items from a menu located across the top of the screen. The left button is used for everything else.

How the Program is Organized

Refer to the PageSetter Function Analysis (Appendix A) for a the following breakdown of the program.

1. Start with 'Desktop Environment' at the top of the diagram and work downward.

'Desktop Environment' refers to the picture of a desktop that appears on the screen when the program is run.

2. The screen has three logical parts:
 - a. the 'Menu' across the top of the screen
 - b. the 'Garbage Can' in the bottom left corner of the screen, and
 - c. the 'Desktop Tools' on the right side of the screen.

- a. Menu

- i. When the mouse pointer is moved to the top of the screen and the right mouse button is

pressed down and held down,

this menu appears

Project Department Artboard Page Box Preferences

- ii. Moving the mouse pointer over one of these, Department, for example, will cause a submenu to drop down. In this case you will get

Department

Text Editor
Graphic Editor
Press

- iii. Moving the mouse pointer down through the list will cause each item in the list to be highlighted as the pointer passes over it. If the right mouse button is released on any submenu item then that item is selected.

- iv. Sometimes there is a list of items attached to a submenu item. This list

drops down when the pointer passes over a submenu item. In the previous example, Press has a list of options attached to it. Moving the pointer down to Press (with the right button still depressed) will result in this

Department
Text Editor
Graphic Editor
Press
 current page
 entire document

v. In this case releasing the button on 'Press' will have no effect. It must be moved to one of the Press sub-items and released to make a Press selection.

b. Garbage Can

i. The Garbage Can, which appears on the computer screen as a picture or icon in the lower left corner of the screen, is used to dispose of unwanted boxes.

ii. Items (boxes) to be disposed of are selected by moving the mouse pointer over them and the left mouse button

is clicked and held down

until the operation is complete.

iii. The pointer will change into a hand after the button is held for a short time. Moving the hand over the garbage can will drag the box over the garbage. Releasing the mouse button 'throws the box into the trash'. It cannot be recovered.

c) Desktop Tools

1. In the right margin of the screen are a number of icons representing Tools. Some of these tools are used to create and manipulate the text and graphic boxes. The others are used to turn on and off the page layout aids.

Page Layout Aids

Page layout aids are:

Box outlines on/off
Page margins outline on/off
Grid on/off
Grid snap on/off
Ruler on/off
Magnify

Box Tools

Box tools are:

 Creat box
 Create Quicktext (up to 99 characters directly into a box)
 Write text into the box from Text Editor
 Paint graphics into box from Graphic Editor
 Mop contents of box (erase)
 Link text boxes
 Unlink text boxes
 Next box (jump to next linked box)
 Previous box (jump to previous box)
 Graphic adjust (move a picture in the box)
 Box to front (moves a box in front of other boxes)
 Box to back (moves a box behind other boxes)

Procedure

Loading the Program

Do This:

1. Turn on the computer, monitor and printer.
2. Keeping the label up, and the metal window on the disk towards the computerPlace the PageSetter disk into diskdrive DF0:
(internal drive in an Amiga 500 or 1000,
right hand drive in an Amiga 2000).

This Will Happen:

The computer will read the disk and display this picture on the screen:



Do This

3. Using the mouse, place the pointer over the disk picture or ICON on the monitor and click twice with the left mouse button.

This Will Happen

This will appear on the screen



Desktop Publishing
Technology Learning Activity 1

388

Running the Program

Do This

1. Place the pointer on the program icon inside the box and click twice (left button).

This Will Happen

The program will load and run.

Setting Page Defaults

Information: Please Read

This is the Page menu and the Default submenu:

Page	
Create	
Save	
Delete	
Load	
Current	
Default	Select this item

1. Selecting Page Default

Do This

- Use the mouse and move the pointer to the top of the screen
- Depress the right mouse button and keep depressed
- Move pointer over Page and then down to Default
- release mouse button while still on Default.

This Will Happen

This window will appear on the screen:

Default Page Format	
Dimensions in Inches	
Page	10.0000 x 14.0000
Format	10.0000 x 14.0000
Margins	
Top:	1.0000
Bottom:	1.0000
Left:	1.0000
Right:	1.0000
Columns	10
Width:	10.0000
[OK] [Cancel]	

2. Set Page Parameters

Information: Please Read

- How to set page default parameters:
- place the pointer in the appropriate box
 - click the left mouse button to select the box
 - use the delete and/or backspace keys to erase the contents of the box
 - type in the new parameters.

Do This

- Set the following page Default parameters

PAPER std
FORMAT legal
MARGINS
Top 1.25
Left 1.25
Bot 1.25
Rt 1.25
* Width 3.00
Columns 2

- * NOTE: Set the width before setting the number of columns

Information: Please Read

These settings will be used by the program every time a page is created. At any time, a page may be selected using the

Page
Current

menu, and the parameters reset for that page.

Setting Box Defaults

1. Selecting Box Default

Do This

- a. Using the right mouse button as before, select the Box menu and Default submenu.

Box

— Current
Default

Select this one

This Will Happen

This window will appear on the screen.



Information: Please Read

How to Set Box Defaults

Use the same procedure as for setting page defaults:
ie. select default box by clicking in box with left mouse button and then enter the new numbers.

2. Setting Box Defaults

Do This

a. Set Box Defaults

Refer to previous diagram.

1. Select a new text font
Point and click in the font box with

topaz 9

This Will Happen

This window will appear on the screen on top of the other window:

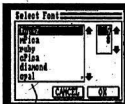

Do This

- ii. Select the font
Click on the up or down arrows to the immediate right of the list of font names until

diamond

is highlighted
- iii. Select font size
Using the same method, select font size

12

from the small box to the right of the font names.
- iv. Accept the changes and exit the font window by selecting

OK

in the font window (the top OK on the screen)
- b. Set the box left margin by selecting the box, erasing the numbers, and typing in

2.000
- c. Accept the settings
Leave all other box parameters as is for now and accept the changes by selecting

OK

This Will Happen

The box window will disappear.

Setting ArtBoard Defaults

1. Select Artboard Defaults

Do This

- a. Select the Artboard menu:

Artboard
Grid Spacing
Ruler Spacing
inches
picas

Each of these has a submenu which must be set.

- b. Select Grid Spacing

This Will Happen

This submenu appears

Artboard
Grid Spacing
1/2 "
1/4 "
1/8 "
1/6 " (pica)

Do This

1. Set Grid Spacing

Select

1/4 "

by releasing the right button
on that option.

Information: Please Read

Ruler Spacing is on this menu

Artboard

Grid Spacing

Ruler Spacing

1/8 "

1/6 " (pica)

Do This

c. Set Ruler Spacing

Select

1/8 "

and release the button.

Information: Please Read

This completes the Artboard setup. The grid will have 1/4 " spacing when it is turned on, and the ruler will have 1/8 " spacing.

Creating a Text File

Information: Please Read

The first thing needed to do a page layout is a body of text. You will now create a piece of text.

1. Open the Text Editor

Do This

- a. Select the Text Editor from the Department Menu.

Department
Text Editor
Graphic Editor
Press

Information: Please Read

This will move control from the desktop that you are currently working in to a separate program called the Text Editor.

This is a very simple word processor. The first operation you will perform is loading a text file that is on the PageSetter program disk

2. Load a Text File

Do This

- a. Select Load File
Select 'Load' 'Textcraft' from the
Project menu.

Project
Load
Generic
Scribble!
Textcraft

This Will Happen

This window will appear on the screen



Information: Please Read

The window shows a list of files and
programs on the disk.

Do This

- b. Select the File (see NOTE below)
Sample One
by clicking on it.

This Will Happen

The name Sample One will appear in the file box at the bottom of the window.

NOTE: If the filename does not appear in the window, place the pointer on the scroll bar at the right side of the window, hold down the left mouse button and drag it down until the name appears in the window.

An alternate method is to click on the up/down arrows above and below the scroll bar.

Do This

- c. Load the File
When the name of the file "Sample One" appears in the File box at the bottom of the window
 - i. Load it by selecting

OK

at the bottom right side of the window.

This Will Happen

A window will appear with the options

Cancel Append Load

Desktop Publishing
Technology Learning Activity 1

399

Do This

ii. Select

Load

This Will Happen

This will load the text into the computer and give the following display



Edit (change) the Text

Information: Please Read

How to Use the Text Editor

Moving through the text.

There are several methods of moving the cursor to any location needed in the text:

1. Use the cursor keys (arrows) to move the cursor up/down and left/right.

Holding down the Shift key while pressing the cursor keys results in faster movement through the text.

2. Position the cursor by placing the mouse cursor in the correct position and clicking the left mouse button.
3. For text positions off the screen use the drag bar or the up/down arrows on the right side of the screen and then use the mouse pointer to get the exact location.

Entering text.

When the cursor is placed in the desired location text is entered by typing on the keyboard.

One thing to remember about text editors is

do not press Return (or Enter)

except at the end of a paragraph. When text reaches the end of a screen line it wraps automatically to the next line.

Editing text.

Text may be deleted by using the Del(etc) key to erase text under the cursor and to the right of the cursor.

The Backspace key deletes text to the left of the cursor.

There are other editing methods, but these will do for this exercise.

Do This

1. Place the cursor on the line below the end of the text.
2. Add the following text to the end of the file

Solar Cells are used on most satellites and space vehicles. They provide prime power, or charge on-board batteries. One possible space project that has received some attention is a solar-powered satellite. It would have a huge array of solar cells to collect the sun's energy. The energy would then be sent to the earth using a microwave beam.

Make sure that the Return key is pressed after all text is entered (ie. after beam.).

This Should Happen

The cursor should end up on the line below the last text line.

Save the New File

Do This

1. After the changes are complete, select Save from the project menu.

Project
Load
Print
Save
Clear text
Clear paste
Exit

This Will Happen

This will result in this window on the screen



Do This

2. Select the File box and type

NewFile

(or any name you wish) and then

Desktop Publishing
Technology Learning Activity 1

403

3. Select

OK

to save the file.

Desktop Publishing
Technology Learning Activity 1

404

Exit to the Desktop
2

Do This

1. Select 'Exit' from the 'Project' menu.

Project
Load
Print
Save
Clear text
Clear paste
Exit

This Will Happen

Control will be returned to the page layout program.

Create a Page

1. Select Page Create

Do This

- a. Select 'Create' from the 'Page' menu.

Page
Create
Save
Delete
Load
Current
Default

This Will Happen

A window will appear on the screen similar to the one on page .

Do This

- b. Select

OK

This Will Happen

The new page will be created.

This will result in a white block, representing a page, appearing on the screen.

The picture is on the next page.

Desktop Publishing
Technology Learning Activity 1

406

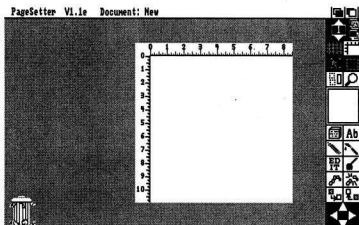

Information: Please Read

Page layout aids are turned on by selecting with the left mouse button. When they are on, they are the same colour as the page.

Page Layout Aids and Box Tools are shown in this Diagram.

2. Set the Page Layout Aids.

Do This

- a. Make these settings.
 - i. Turn Grid off.
 - ii. Turn Snap on.

Information: Please Read

This snaps the top left corner of each box that is created to the closest grid intersection. This is an aid in text alignment.

- iii. Turn Ruler on.
 - iv. Turn Margins on.
 - v. Turn BoxOutline on.
3. Select magnification.

Information: Please Read

There are three sizes of magnification available, small, medium, and large.

- Text can only be read in the largest size, and that will be necessary at a later stage.

Do This

- a. Select the magnify option until the medium size page appears.

This Will Happen

At this point the page should have two text boxes (columns) showing.

4. Placing Text in the Boxes.

Do This

- a. Select the Write (pencil) tool.
- b. Point into the left text box and click the left mouse button

This Will Happen

Text from the text editor will flow into the box.

5. Getting Text into the Second Box.

Information: Please Read

The second box must be linked to the first in order for text to flow into it.

Do This

- a. Click on the left text box to make sure that it is highlighted.

BOTY

Select.

The box link tool

by clicking on it with the left mouse button.

- c. Move the new pointer over the right text box and make sure that the top left corner of the pointer is in the box.
- d. Click the left mouse button.

This Will Happen

Notice that text flows into the right text box.

— 6. Moving Around on the Page

Information: Please Read

The Page position window shows a page colored block inside a rectangle. The colored block represents the portion of the page that is visible on the screen. Low magnification shows the block the same size as the rectangle. Medium and high magnification show blocks smaller than the rectangle.

To move around on the page in medium or high magnification select the block and move it around in the rectangle with the mouse. A different portion of the page will appear on the screen.

7. Setting Magnification Level

Do This

- a. Select
High magnification
- b. Move the screen view around with the page positioner and read the page.

Save the Project

Information: Please Read

This saves a copy of the page layout as a project file.

The project file is entirely different from the text file saved earlier. The text file cannot be loaded directly into the page layout part of the program, and the page layout file (project) cannot be loaded into the text editor.

— **Selecting Save As...**

This selection is used when saving a file for the first time. After it is saved, the name of the file appears at the top of the screen. The next time you save, just select

Save \

and the old file will be replaced with the updated one.

1. **Save the New Project File**

Do This

- a. Select **Save As...** from the Project menu.

Project
New
Open
Save
Save As...
Quit

This Will Happen

This window will appear on the screen.



Do This

- b. Type the name of the project into the file box and select

OK

This Will Happen

The project file will be saved.

Printing the Page

Information: Please Read

This operation puts a copy of the page onto paper. In this exercise a dot matrix printer is used.

The page is printed as a graphic screen dump. It does not use the built in character fonts of the printer.

Do This

1. Before beginning, set the paper so that the page separation perforations are just above the print head of the printer.
2. Make sure that the printer 'on line' light is on.
3. Print the Page

Do This

- a. Select Press Current Page from the Department menu

Department
Text Editor
Graphic Editor
Press
current page
entire document

This Will Happen

This window will appear on the screen

Scale to fit
page size

Pixel image
(no scaling)

Do This

- b. Select

Scale to fit
page size

This Will Happen

This window will appear

Set paper to top of form

No

Yes

Do This

- c. Select

Yes

This Will Happen

There will be a pause and then the page
will print.

Exiting the Program

When done exit the program.

Do This

1. Select Quit from the Project menu

```
Project
  New
  Open
  Save
  Save As...
  Quit
```

This Will Happen

This will cause the computer to exit the program.

Do This

2. Remove the disks from the computer, and turn off the power.
3. Turn in the completed page to the instructor.

Technology Education: 415
With Specific Applications in Industrial Technology

Information Communications Technology

Desktop Publishing

Technology Learning Activity 2

Leon Cooper

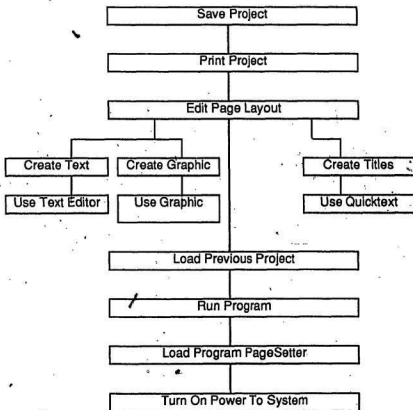

General Objective

Students will use a desktop publishing package to create page layouts using text files and graphics files.

Specific Objectives

Each student will perform the following within a two hour time period

1. Load a previously created PageSetter project file.
2. Resize the existing text boxes.
3. Unlink the existing text boxes.
4. Create new text boxes.
5. Link all text boxes in the correct sequence.
6. Add Titles using QuickText boxes.
7. Create graphic boxes.
8. Open the Graphic Editor.
9. Load a graphic image.
10. Clip the image.
11. Exit the Graphic Editor.
12. Paste the image into the graphic box.
13. Save new project file, print page and exit using procedure learned in TLA 1.

Equipment Supplied

- 1 Amiga computer
- 1 PageSetter Program Disk
- 1 program data disk
- 1 printer

Instructional Materials Supplied

Instructional package including
Description of PageSetter Program
Instructions for completing activity

Instructions

1.. Note that if you are required to do something the following prompt will appear:

Do This

2. When something is supposed to happen this prompt will be on the page:

This Will Happen

3. Please read all information following the prompt:

For Your Information - Please Read

since it contains information vital to understanding the operation of the program.

For Your Information - Please Read

The Pagesetter Program

Description of the Program

This program is used to create page layouts. Pages consist of text and graphic images or pictures. The program simulates a desktop. Pages can be placed on the desktop by 'creating' them. Text and images can be placed on the pages by creating 'boxes' on the pages, and then placing the text or graphics in them.

Global parameters can be set for the pages, so that each page created will be the same size, and have the same margins (nothing placed outside the margins will print when the page is printed).

Global parameters can be set for the boxes. Some of the box parameters are: the same kind and size of characters, the same frame around the box, the same text spacing or kerning (distance between characters and between words), and the same leading (distance between lines of text). Margins set for boxes alter the distance from the edge of the box to the text, and are therefore different from page margins. Text boxes may be set to have text aligned on the left margin, on the right margin, on both margins, or centered between the margins.

In addition a page or a box can be selected at any time and the parameters for that page or box changed.

Text boxes may be linked together so that text flows from one to the next automatically.

Graphic images may be moved around within a box and cropped by changing the size of the box so that only part of the picture shows through.

Boxes may be moved around on the page and off the page and placed onto the desktop or

'artboard'. From there they may be moved onto another page.

Pages may have one of three levels of magnification. The smallest shows the entire page at one time, medium shows about three quarters of the page, and high magnification shows about 1 sixteenth of a page. High magnification is the only one that allows all text sizes to be read.

There are a number of page layout aids. They are:

1. a grid for alignment
2. a grid snap which forces the top left corner of a box to go to grid intersections
3. a ruler to show dimensions in inches or picas
4. page margin outlines
5. box outlines to show the edges of boxes that have no visible frames and to show the currently 'active' box (the one being worked on).

Creating Text and Pictures

Text may be created three ways:

1. With a Quick text option for up to 99 characters
2. With the Text Editor
3. By using the Text Editor to bring in a text file created in another wordprocessing program.

Graphic images may be created two ways:

1. With the Graphic Editor
2. By using the Graphic Editor to import a picture from a painting program.

Input Devices

This program runs on an Amiga computer. It accepts input from the keyboard and from the mouse. The mouse (Diagram 1) has two buttons. The right button is always used for selecting

items from a menu located across the top of the screen. The left button is used for everything else.

How the Program is Organized

Refer to the PageSetter Function Analysis (Appendix A) for a the following breakdown of the program.

1. Start with 'Desktop Environment' at the top of the diagram and work downward.

'Desktop Environment' refers to the picture of a desktop that appears on the screen when the program is run.

2. The screen has three logical parts:
 - a. the 'Menu' across the top of the screen
 - b. the 'Garbage Can' in the bottom left corner of the screen, and
 - c. the 'Desktop Tools' on the right side of the screen.

a. Menu

- i. When the mouse pointer is moved to the top of the screen and the right mouse button is

pressed down and held down

this menu appears

Project Department Artboard Page Box Preferences

- ii. Moving the mouse pointer over one of these, Department, for example, will cause a submenu to drop down. In this case you will get

Department
Text Editor
Graphic Editor
Press

- iii. Moving the mouse pointer down through the list will cause each item in the list to be highlighted as the pointer passes over it. If the right mouse button is released on any submenu item then that item is selected.
- iv. Sometimes there is a list of items attached to a submenu item. This list drops down when the pointer passes over a submenu item. In the previous example, Press has a list of options attached to it. Moving the pointer down to Press (with the right button still depressed) will result in this

Department

Text Editor
Graphic Editor
Press

current page
entire document

- v. In this case releasing the button on 'Press' will have no effect. It must be moved to one of the Press sub-items and released to make a Press selection.
- b. Garbage Can
- i. The Garbage Can, which appears on the computer screen as a picture or icon in the lower left corner of the screen, is used to dispose of unwanted boxes.
 - ii. Items (boxes) to be disposed of are selected by moving the mouse pointer over them and the left mouse button

is clicked and held down

until the operation is complete.
 - iii. The pointer will change into a hand after the button is held for a short time. Moving the hand over the garbage can will

drag the box over the garbage. Releasing the mouse button 'throws the box into the trash'. It cannot be recovered.

c. Desktop Tools

- i. In the right margin of the screen are a number of icons representing Tools. Some of these tools are used to create and manipulate the text and graphic boxes. The others are used to turn on and off the page layout aids.

Page Layout Aids

Page layout aids are:

- Box outlines on/off
- Page margins outline on/off
- Grid on/off
- Grid snap on/off
- Ruler on/off
- Magnify

Box Tools

Box tools are:

- Create box
- Create Quicktext (up to 99 characters directly into a box)
- Write text into the box from Text Editor
- Edit box contents
- Paint graphics into box from Graphic Editor
- Mop contents of box (erase)
- Link text boxes
- Unlink text boxes
- Next box (jump to next linked box)
- Previous box (jump to previous box)
- Graphic adjust (move a picture in the box)
- Box to front (moves a box in front of other boxes)
- Box to back (moves a box behind other boxes)

Loading the Program

Information: Please Read

This activity uses the project file that was saved in TLA 1.

Use the procedures in TLA 1 to load and run the program.

Do This

1. Load and Run the Program

Loading The Project

Information: Please Read

This is the Project menu

Project
New
Open
Save
Save As...
Rename
About
Quit

Do This

1. Select **Open** from the **Project** menu.

This Will Happen

This window will appear



Information: Please Read

The file that is currently selected is the one that has the band across it. Use the arrows to the right of the files to scroll up and down.

Do This

2. Scroll down the list of files and select (click the pointer on)

ps1

or the name that you used to save the project in TLA 1

This Will Happen

The name ps1 will appear in the file box at the bottom

Do This

3. Select

OK

This Will Happen

The project will be loaded.

Information: Please Read

- * Note that it will be loaded in the magnification that was last used before the project was saved.

Editing the Project (How to)

Information: Please Read

In order to add a picture and titles to the page, the text boxes must be resized and new boxes added.

Box links will have to be broken and new ones made.

A new page layout will be created similar to this picture.



How to Edit Boxes

Resizing the Boxes.

Boxes are resized by pointing to the lower right corner of the box and holding down the left button.

The pointer turns into a hook which grabs the corner of the box.

The box is then dragged out or in to the new size by moving the hook.

As the box is resized a set of coordinates appear in the top right corner of the screen. They show the width and height of the box being resized.

When the correct size is reached,
release the button.

Moving the Boxes.

Boxes are moved by placing the
pointer inside the box borders and
holding the left button down.

The pointer turns into a hand.
Dragging the hand moves the box
around the screen.

When the button is released, the box
stays in that position.

Edit the Program

1. Set Magnification

Do This

- a. Set Magnification on
Low

This Will Happen

The screen will change to the new magnification.

2. Resize Box

Information: Please Read

It may be necessary to change magnification and reposition the page several times while performing this operation.

Do This

- a. Start in low magnification.
 - i. Hook the bottom right corner of the left text box.
 - ii. Resize it to 3.000 by 4.000 so that the bottom of the box is at
5 1/4 inches

This Will Happen

The top of the box should be at the top page margin of

1.25 inches

Do This

iii. Resize the right hand text box to exactly the same size as the left text box.

3. Move Text Boxes

Information: Please Read

The next step is to move the boxes to make room for the picture and the title.

Boxes are moved by placing the pointer in the box, holding down the left button until the pointer turns into a hand, and still holding down the button, dragging the box to the new location.

Note that for this activity, the side borders of the box should be on the page column margins (dashed lines).

Do This

- a. Select the left box.
- b. Move the box so that the top border of the box is at

2 1/4 inches

u

This Will Happen

The bottom of the box should be at
6 1/4 inches ✓

If it is not, resize.

Do This

c. Repeat this operation for the right text box.

This Will Happen

The right text box should be aligned with the left text box.

Information: Please Read

You may notice that the right bottom corner of the right side text box has a small square attached. This shows that there is more text than can fit in the box.

New boxes must be created to hold the text.

4. Create New Text Boxes

Information: Please Read

A new box will be created in both of the text columns shown on the screen.

Do This

- a. Select the
Text box tool

This Will Happen

The pointer will be replaced with a set of crosshairs.

Do This

- b. Move the crosshairs to the left page margin at
8 $\frac{3}{8}$ inches
down the ruler.
- c. Hold down the left mouse button and drag the crosshairs down and to the right to create a box with dimensions
3.000 by 1.375 (1 $\frac{3}{8}$)

This Will Happen

This will result in the bottom right of the box aligning with the bottom margin and the middle margin.

Do This

- d. Repeat this operation and place a new text box of the same size and in the same relative position in the second column.

5. Unlink Text Boxes

Do This

- a. Select the top left text box by clicking in it with the left button.
- b. Select the

Unlink tool

on the right of the screen.

- c. Click the unlink tool into the top right text box.

Information: Please Read

This breaks the link between the two text boxes.

6. Link Text Boxes

Do This

- a. Click into the top left text box to select it.

- b. Select the

Link tool

from the box tools.

- c. Click the link tool into the bottom left text box

This Will Happen

This will link the two boxes and will select the bottom left box so that it is highlighted.

Do This

- d. Select the Link tool again and click into the top right text box.

This Will Happen

The top right box will be highlighted.

Do This

- e. Select the Link tool one more time and click into the bottom right text box.

This Will Happen

All text boxes are now linked and each should be filled with text.

7. Create a Title

Information: Please Read

A new text box must be added for the title. The QuickText tool will be used to enter the title.

Do This

- a. Set New Box Defaults
 - i. Select Default from the Box menu

Box	Current
	Default
 - ii. Set the following parameters

Text alignment :	Centered
Font :	mPica
Font size :	40
Border size :	Single wide line
Border style :	Top and Bottom
- b. Create the Title Box

Do This

- i. Use the same box tool selection process as before.
- ii. Place the crosshairs at
1.250 by 1.250
or the top left page margin.
- iii. Create a new text box with measurements
7.000 by 0.750

This Will Happen

The right bottom corner of the box will
be at position

7.25 by 2.00

8. Entering the Title

Do This

- a. Select the QuickText Tool

This Will Happen

This box appears on the screen

Enter text	
Erase	Cancel OK

Do This

- b. Click in the box and enter the following
text

Solar Energy

Information: Please Read

To place the text on the page do one of
the following

- i. Press

Return

or

ii. Select

OK

The text will then be placed in the box and the title is completed.

Do This

c. Place the text on the page.

9. Creating a Picture

Information: Please Read

Pictures may be added by creating a box to place them in.

The Graphic Editor is then used to create a picture.

Alternately a picture may be loaded into the Graphic Editor from another drawing program.

When the picture is into the editor it must be Clipped to add to the page.

a. Create the Graphic Box

Do This

i. Select the Box Default and make the following changes

Border size
line

Single narrow

Border position

Complete frame

- ii. Using the same procedure as before, create a box with dimensions

7.000 by 1.625 (1 5/8)

This Will Happen

The top left corner of the box will be at 6 3/8 inches down the left page margin.

The bottom right corner of the box will be 8.00 inches down the right page margin.

- b. Use the Graphic Editor

Do This

- i. Open the Graphic Editor

Select Graphic Editor from the Department menu

Department
Text Editor
Graphic Editor
Press

This Will Happen

A screen will appear with this box at the bottom left side

Information: Please Read

Note the position of the Frame tool.

- c. Load the Graphic Image

Do This

- i. Select Load from the Project menu.

This Will Happen

The file window will appear on the screen.

Do This

- ii. Scroll down throught the list until solarcar1 appears.

- iii. Select

solarcar1

This Will Happen

solarcar1 will appear in the file-box.

Do This

- iv. Select

OK

This Will Happen

The picture will be loaded.

- d. Frame the Picture

Do This

- i. From the box at the bottom left of the screen, select the

Frame tool

Information: Please Read

Use the tool as you would the bpx tool from the desktop.

Do This

- ii. Starting at the left side of the screen and about one third the way down

draw a box around the car

so that the frame is halfway down between the car and the bottom of the screen and is at the right side of the screen.

- e. Clip the Picture

Do This

- i. Select Clip Scale 5:4 from the Frame menu

Frame
Clip
Scale 5:4
Scale 1:1

This Will Happen

This will clip the portion of the picture

that was just framed. It is saved in a special memory location called the clipboard.

- f. Exit the Graphic Editor

Do This

- i. Select Exit from the Project menu

```
Project )
        Load
        Save
        Save as
        Clear
        Exit
```

This Will Happen

This will return you to the desktop.

10. Pasting the Picture into the Page

Information: Please Read

The picture must now be pasted into the box created earlier.

- a. Select Paint Tool

Do This

- i. Select the paint tool from the tools at the right.

This Will Happen

The pointer will change into a paintbrush.

- b. Paste the Picture on the Page

Do This

- i. Place the brush into the graphic box and click the left button.

This Will Happen

The picture will appear in the box.

- c. Centering the picture in the Box

Do This

- i. Center the picture using the Graphic adjust arrows at the bottom right corner of the screen.

11. Add a Title to the Picture

Do This

- a. Select Page Default and set these parameters

Top Margin	0.05
Border size	None
Font	Diamond
Font size	12

- b. Select the **Box create** tool and create a box with dimensions

1.500 by 0.625

at the bottom left corner of the picture.

- c. Select the **QuickText** tool

i. Erase the text in the box that appears.

ii. Click in the box and enter the following

Solar Car

iii. Select

OK

Save the Project File

Information: Please Read

This project was saved before, so it can now be saved by using Save from the Project menu

Project

New
Open
Save
Save as...
Rename
ABout
Quit

The file will be saved with the same name and will overwrite the old file on the disk.

Do This

1. Save the project

Print the Project

Information: Please Read

The page may now be printed using the same procedure as in TLA 1 by selecting Press - current page from the Department menu.

Make sure to set the paper as before and respond properly to the prompts on the computer screen.

Do This

1. Print the Project

Quit the Program

Do This

1. When You are satisfied with the results, Quit the program and pass in the page to the instructor.
2. Shut down all equipment.

