

FACTORS INFLUENCING DECISIONS AT THE
DISTRICT LEVEL REGARDING FRENCH PROGRAMMES

CENTRE FOR NEWFOUNDLAND STUDIES

**TOTAL OF 10 PAGES ONLY
MAY BE XEROXED**

(Without Author's Permission)

BARRY WILLIAM ROWE



**FACTORS INFLUENCING DECISIONS AT THE
DISTRICT LEVEL REGARDING FRENCH PROGRAMMES**

BY

©Barry William Rowe, B.A., B.Ed.

**A thesis submitted to the School of Graduate
Studies in partial fulfilment of the
requirements for the degree of
Master of Education**

**Department of Curriculum and Instruction
Faculty of Education
Memorial University of Newfoundland
1994**

St. John's

Newfoundland

ABSTRACT

The purpose of the study was to investigate some characteristics and views of Newfoundland district superintendents in order to determine what factors influence their decisions regarding French programmes and to what extent they influence these decisions, in general.

At the basic level, French programmes are provided to school districts from the Language Programmes Section of the Department of Education. It is, therefore, within a school district's mandate to provide these same programmes to the students they serve. Following this, there are several questions that can be raised:

1. Why do different school districts have a variation in instructional time allocated to core French?
2. Why is there a wide variety of French programmes existing within our province?
3. Why do some school districts not have a French Programme Coordinator?
4. Why do some school districts have only a core French programme?
5. Why do only some school districts have early/late French immersion programmes?
6. Who (and what) influences decisions regarding French programmes at the district level?

These are but some of the questions that can be asked concerning French programmes in Newfoundland school districts. The writer feels that the answers to these questions are influenced by the district superintendent in each school district.

The data sources were semi-structured interviews with eight district superintendents chosen at random and a survey instrument, designed by the author, sent to all twenty-seven district superintendents. There was a 100 percent response rate to the survey instrument, but only 88 percent used.

The survey instrument dealt with background/professional information, decision-making information and opinions concerning French programmes. Once the data was collated, cross analyses were done to see if any similarities existed or any patterns emerged.

The results of this study show that Newfoundland district superintendents are a very homogeneous group - mostly "born and bred" Newfoundlanders. The average respondent completed a Bachelor of Arts degree as an undergraduate degree at Memorial University of Newfoundland and holds a graduate degree in educational administration from outside the province.

In general, the district superintendent makes the first decision dealing with the priority given to French. Beyond that, decisions are made by the French programme coordinator. Of the six subject areas given to district superintendents to rank on a priority basis, French was ranked as number six.

It appears that their lack of social and educational experiences outside Newfoundland has influenced the Newfoundland district superintendents' priority given to French. Their close ties with Newfoundland do not permit them to see the value that a knowledge of French has in Canada.

DEDICATION

This Thesis is dedicated to my mother and father, Therza and William Rowe, of Baie Verte, Newfoundland. Their constant support and encouragement for my educational pursuits throughout the years will be forever remembered.

ACKNOWLEDGEMENTS

The writer wishes to acknowledge the invaluable assistance provided by his advisor, Professor Joan Netten. Without her cooperation and advice, this thesis would not have reached fruition. Also, in the initial stages of this project, Dr. Glenn Loveless provided input that allowed for a smooth development of the project.

In addition, thanks are expressed to Ms. Debbie McHugh and Ms. Colleen Loder for typing small sections of this project. A special thank you is extended to Ms. Jackie Crocker for the typing of the majority of this manuscript. Also, thanks must be extended to those twenty-seven district superintendents who took time from their busy schedules to complete my survey and/or meet with me. Without their cooperation, this project would not have been possible.

Finally, the writer wishes to acknowledge the thoughtfulness, tolerance and understanding of his wife, Jean. Without her constant encouragement, and sometimes often-needed prodding, the completion of this project would not have come to be.

To others I may have inadvertently omitted - *merci beaucoup*.

TABLE OF CONTENTS

	PAGE
CHAPTER 1	1
INTRODUCTION	1
Related Questions	4
The School District Superintendent	5
Purpose of the Study	10
Need for the Study	11
Significance of the Study	12
Limitations of the Study	13
Definition of Operable Terms	13
Organization of the Thesis	14
CHAPTER 2	15
REVIEW OF LITERATURE	15
Characteristics of the Superintendency	15
Importance of Educational Planning	17
The Duties of the Newfoundland District Superintendent	19
The District Superintendent and Second/Foreign Language Study	22
The Defilippis Study	22
The Weatherford Study	24
The Beard Study	25
The Canadian Context	27
Conclusions	28
CHAPTER 3	30
RESEARCH DESIGN AND METHODOLOGY	30
The Study	30
Research Questions	31
The Instrument	32
The Population	33

CHAPTER 4	35
ANALYSIS OF DATA	35
Background/Professional Information	35
Decision-Making Information	43
Role of French Programme Coordinator	44
Inservice Activities	45
Department of Education Guidelines	46
French Programme Implementation	48
The Role of French in the Curriculum	49
Relationships Between Background Characteristics and Views of District Superintendents	55
CHAPTER 5	59
SUMMARY, CONCLUSIONS AND RECOMMENDATIONS	59
Summary	59
Conclusions	60
Research Questions: Finding	64
Related Questions: Answers	66
Further Comment on Particular Issues	68
Recommendations for Action	70
From Study	70
For Further Study	71
BIBLIOGRAPHY	72
APPENDICES	78
APPENDIX A Questionnaire	79
APPENDIX B Correspondence (Field Testers/ Interviewed District Superintendents)	92
APPENDIX C Covering Letter	107
APPENDIX D Correspondence (Miscellaneous)	110

LIST OF TABLES

	PAGE
Table 1.1	Size of Newfoundland School Districts 8
Table 4.1	University Degrees of Newfoundland District Superintendents 36
Table 4.2	Graduate University Degrees of Newfoundland District Superintendents - The Different Universities 36
Table 4.3	Classroom Teaching Experience of Newfoundland District Superintendents 37
Table 4.4	District Superintendents' School Administration Experience 38
Table 4.5	District Office Experience of Newfoundland District Superintendents 39
Table 4.6	District Superintendents' Years of Experience 39
Table 4.7	District Superintendents' Exposure to French and Other Second Languages 40
Table 4.8	Newfoundland District Superintendents' Social Experiences Outside Newfoundland 41
Table 4.9	District Superintendent Involvement in Inservice Session 46
Table 4.10	Problems in Implementing French Programmes 48
Table 4.11	Main Reasons for Studying French 50

	PAGE
Table 4.12 Knowledge of/Proficiency in Subject Area Ratings	51
Table 4.13 Opinion Statement Responses	53

LIST OF FIGURES

	PAGE
Figure 1.1 Administrative Organization	3
Figure 1.2 Integrated School Districts	6
Figure 1.3 Roman Catholic School Districts	7

CHAPTER 1

INTRODUCTION

The various French programmes in Newfoundland school districts have received considerable attention in recent years. The ever-changing field of second language methodology, the availability of early/late French immersion programme offerings and the advent of French first-language schools all add complications to an already complex situation.

Added to these diversifications at the provincial level, there are differences existing within different school districts regarding French programme options. At the basic level, French curriculum is provided to school districts from the Language Programmes Section of the Department of Education. It is therefore within a school district's mandate to offer this curriculum to the students they serve. ¹Wide differences, however, still exist.

The position of the district superintendent in Newfoundland is a powerful one. Although responsibility for decisions made in a school district rests legally with the school board, the district superintendent, as Chief Executive Officer (CEO), plays an important role. Boich et al (1989) in discussing the role of the district superintendent state:

"Yet directors [district superintendents] also occupy an undeniably powerful, if delicate, position. Their strategic location at the interfaces between the board, the system and the wider policy environment provides them with unique opportunities to accumulate information and develop a well-informed understanding of issues and options... At the same time their role requires them to use this unique knowledge to balance, arbitrate, and when possible, harmonize many diverse and often conflicting expectations and demands." (p. 91)

Therefore, this study focuses on the district superintendent.

The Newfoundland Department of Education has its power and authority primarily in the financial wing of educational operations. Although district superintendents control/manage the district operation, they are constrained to some extent by the conditions accompanying financial grants from the Department of Education. The administrative organization of the provincial Department of Education is outlined in Figure 1.1.

Despite this financial control of the Department of Education, differences still exist in what programmes are offered by school districts to their students. For example, the Report on Primary Core French Questionnaire (1988), published by the Newfoundland Department of Education, indicated that two-thirds of Newfoundland school districts were offering primary core French. Of those school districts offering primary core French, a range of thirty (30) to ninety-three (93) contact hours per year was reported at the kindergarten level (Report on Primary Core French Questionnaire, 1988).

Figure 1.1 Administrative Organization

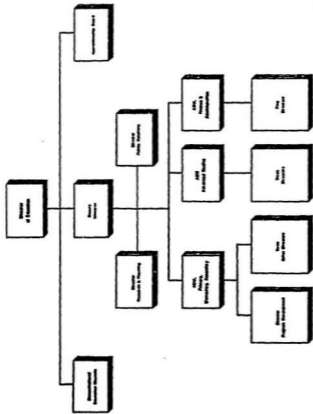

Title: Organizational Chart A: Department of Education
(Adapted from Department of Education Directory, 1991-92)

Title: Organizational Chart B - School Board
(Adapted from Western Integrated School Board Policy Manual, 1994)

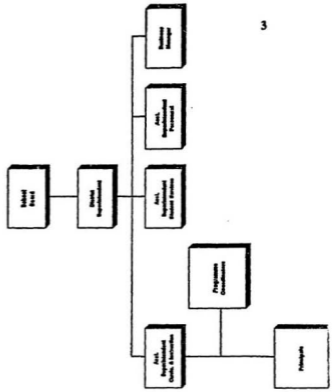

The Report of the Policy Advisory Committee on French Programmes (1986) also illustrates similar differences occurring in Newfoundland school districts. The Report gives some examples of this:

"Some students in grades 4-6 get as little as 60 minutes per six-day cycle, while others get as much as 200 minutes. The allocation of 60 minutes per six-day cycle is 120 minutes less than what has been recommended by the Department." (p. 17)

This finding illustrates once again the amount of variability which exists from school district to school district in core French instruction. It may be hypothesized that the district superintendent, with his/her power and authority, has considerable influence on the importance given to French in the school district.

Related Questions

Bearing in mind that wide differences in French programmes offered by the various school boards in the province do in fact exist, there are several questions that can be raised.

1. Why do different school districts have a variation in instructional time allocated to core French?
2. Why is there a wide variety of French programmes existing within our province?
3. Why do some school districts not have a French programme coordinator?
4. Why do some school districts have only a core French programme?
5. Why do only some school districts have early/late French immersion programmes?

6. Who (and what) influences decisions regarding French programmes at the district level?

These are some questions that can be asked concerning the French programme options in Newfoundland school districts. Some answers can be provided to these questions by discussing school district size, location and geography. Teacher age and qualifications may also be important indicators, but so, too, is the role of the district superintendent.

The School District Superintendent

During the 1991-1992 school year, there were twenty-seven school districts in the province of Newfoundland; fifteen Integrated school districts, ten Roman Catholic school districts, one Pentecostal school district and one Seventh Day Adventist school district. These districts are illustrated in Figure 1.2 and Figure 1.3. Both the Pentecostal school district and the Seventh Day Adventist school district cover the province in its entirety, although they do not have schools in all communities. A clearer picture of the twenty-seven school districts can be seen by viewing Table 1.1. Each school district has a district superintendent who is the chief executive/administrative officer. The duties of the district superintendent are laid down in Section 19 of the 1969 Schools Act. These specific duties will be discussed in Chapter 2, and the duties regarding the oversight of curriculum will be highlighted.

Figure 1.2 Integrated School Districts

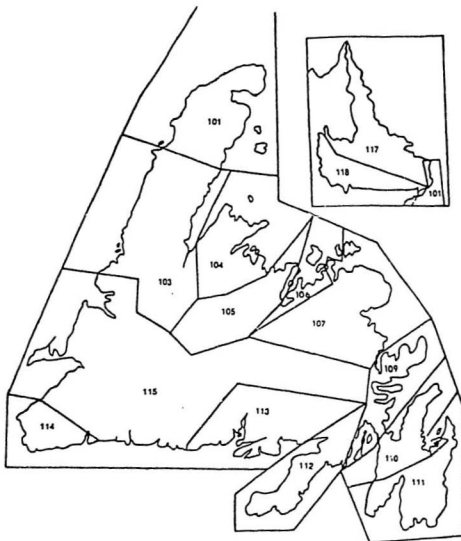

(Adapted from Department of Education Directory 1993-94)

Figure 1.3 Roman Catholic School Districts

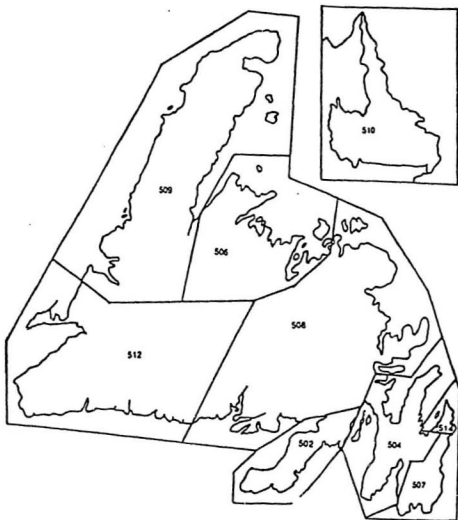

(Adapted from Department of Education Directory 1993-94)

Table 1.1 Size of Newfoundland School Districts*

<u>Integrated School Districts</u>		<u>No. Schools</u>	<u>No. Students</u>
101	Vinland-Strait of Belle Isle	27	3,317
103	Deer Lake-St. Barbe South	23	3,704
104	Green Bay	21	2,589
105	Exploits Valley	18	3,565
106	Notre Dame	13	2,616
107	Nova Consolidated	29	7,189
109	Bonavista-Trinity-Placentia	18	5,833
110	Avalon North	33	7,987
111	Avalon Consolidated	27	11,235
112	Burin Peninsula	12	2,901
113	Bay D'Espoir	12	1,514
114	Port aux Basques	12	2,092
115	Western	17	5,749
117	Labrador East	12	2,175
118	Labrador West	4	1,672
129	Conception Bay South	9	3,497
 <u>Roman Catholic School Districts</u>			
502	Burin Peninsula	14	3,772
504	Western Avalon	31	6,913
506	Exploits-White Bay	14	2,326
507	Ferryland	10	1,930
508	Gander-Bonavista-Connaigre	13	2,234
509	Humber-St. Barbe	20	3,634
510	Labrador	9	2,648
512	Appalachia	19	4,962
514	St. John's	38	19,126
 <u>Other School Districts</u>			
401	Pentecostal Assemblies Board of Education	41	6,289
701	Seventh Day Adventist Board	6	303

* *Statistics for 1992-93 school year.*

The individuals who occupy these key administrative positions within Newfoundland school districts have a unique and difficult task within the organization. Their tasks are unique in that every school district is different with regard to size, location, geography and the various programme options within the schools. Genge (1991) commented that some uniqueness to the position is also derived from the fact that district superintendents have no peers within their educational organization (p. 1). Genge (1991) illustrates uniqueness by stating:

"As chief executive officers, some manage multi-million dollar enterprises, administer large numbers of employees, and are in a position to substantially influence the effectiveness of their systems; others manage much smaller enterprises and have very different task assignments." (p. 1)

Konnert and Augenstein (1990), in examining the uniqueness of the superintendency, noted that one of the prime functions of the position of district superintendent is to provide planning and direction for the school system (p. 50). It follows logically that their sphere of influence extends from administration to student achievement - the primary purpose of schooling. The difficulties associated with the position of district superintendent can compare to the difficulties and conflicts encountered by other executive positions. Blumberg (1985) points out these similarities:

"Executives are expected to provide direction, pay attention to both the internal and external environment upon which their organization's welfare depends, and set in motion procedures for resolving conflict when they are called for. So far, so good. Superintendents are expected to engage in similar activities." (p. 188)

District superintendents are therefore expected to oversee the development of the school district.

Purpose of the Study

Guidelines for French instruction and curriculum materials are distributed by the Language Programmes Section of the Department of Education. However, it has been shown that despite these guidelines, wide variations exist in French programme options in Newfoundland school districts. There are obviously a variety of factors influencing the options made available to each school district. The district superintendent with all his/her power and authority can influence decisions made and interpret guidelines differently.

Because of the effect that the position of district superintendent should have on the school system, a greater understanding of what internal/external factors affect a district superintendent's administration of French programmes could contribute to the development of improved educational experiences for students. This thesis investigates some characteristics and views of district superintendents in order to determine what factors influence the district superintendents' decisions regarding French programmes.

Need for the Study

Many researchers have investigated the roles of Newfoundland district superintendents (Coates, 1978; Kendall, 1985 and King, 1972). Boich et al. (1990) investigated the roles of district superintendents throughout Canada. Konnert and Augenstein (1990) and Blumberg (1985) analyzed the American district superintendent, while Genge (1991) researched effective district superintendents in the province of Alberta. However, the district superintendents' role vis à vis French programmes in particular has never been studied.

Rice (1988) completed a study dealing with French programmes and the influence of school principals in Newfoundland. Dagenais (1990) completed a similar study dealing with school principals and French immersion programmes in the province of Quebec specifically. Murphy (1992) completed a study of the school principal in a combined French immersion and French first language school in Newfoundland. In addition, Gadoury (1991) investigated the administration of French immersion schools in Canada. Once again, however, the specific issue of the district superintendents' impact on French programmes has not been investigated.

Several American researchers have investigated the district superintendent and second language study. Beard (1984) completed a study of school counsellors and district superintendents in Illinois. DeFilippis (1979) investigated school district superintendents in western Pennsylvania. In addition, Klayman (1975) analyzed the views of secondary school educators in New York State on the language requirement

in higher education. Also, Weatherford (1982) investigated the attitudes of district superintendents and high school principals toward second language study in Georgia. In these American studies, French was not the main language on which views were being analyzed and made up only a small component of the studies' findings.

Therefore, a definite need exists for researchers to develop a body of knowledge which will give insight into the role which the district superintendent plays in the implementation and administration of French programmes at the district level, particularly in the Canadian context.

Significance of the Study

A study of this type should be of particular interest to district superintendents. It should assist them in understanding how their role affects French programmes and give them a clearer idea of just what they can do that will "make a difference" with regard to their district's French programmes. In addition, this knowledge could also be used by district superintendents as some sort of "self-hidden advice" when dealing with French programming issues in their respective school districts.

Results of this study may also be very worthwhile for the Department of Education in determining the best ways to approach school districts about improvements in French programmes. Ultimately, the results of this study should contribute to the implementation of improved French programmes for all students in the province, and as a result, a more enriched educational experience.

Limitations of the Study

The study, a survey of the characteristics and views of Newfoundland district superintendents about French education, has two major limitations. The study was not longitudinal in that it concerned itself with school district superintendents who occupied these positions in the 1991-92 school year. Different individuals may have somewhat different views; however, the population was small, and individual views may result in generalizations that would not be applicable if different individuals had been in the positions. Also, the study was somewhat limited in that it took place within the Province of Newfoundland. However, it may be suggested that the study's results could be useful to any district superintendent because the roles are very similar.

Definition of Operable Terms

The following terms and words are defined so there will be general agreement as to their usage in this thesis:

School District	an educational district established by or under a legislative act of government.
District Superintendent	a school board appointee who serves as the chief executive/administrative officer of a school district.
Superintendency	the position held in a school district by the district superintendent.

Newfoundland	the term used in this thesis to refer to Newfoundland and Labrador or the Province of Newfoundland.
French Programme	a curriculum to follow when teaching French.
Second/Foreign Language	any language other than the native language of an individual.
Core French	a separate subject taught in the curriculum of English language schools.
Extended Core French	a programme in which students study French as a subject for about forty minutes per day and also study one other subject (for example, history, science or math) in French.
Early French Immersion	a programme that begins in kindergarten or Grade one with 100 percent instruction in French for at least the first one or two years. Gradually, English language arts and other subjects taught in English are introduced at various grade levels.
Late French Immersion	a programme that begins anywhere from grade six on and generally involves 90 to 100 percent instruction in French the first year and 50 to 80 percent instruction for those years following.

Organization of the Thesis

This chapter, Chapter 1, provides an introduction to the study. Pertinent theoretical and research literature that is available is examined in Chapter 2. Chapter 3 provides details of the research design and the methodology used to complete the study. The results and findings of the study are presented and discussed in Chapter 4, while Chapter 5 provides some discussion of the findings, some conclusions and recommendations for further study.

CHAPTER 2

REVIEW OF LITERATURE

This chapter is concerned with the role of the district superintendent along with a discussion of studies completed dealing with district superintendents and second/foreign language study. The uniqueness of the superintendency is also discussed, along with the specific duties of Newfoundland district superintendents.

Characteristics of the Superintendency

The uniqueness of the role of the district superintendent within the educational system was discussed briefly in Chapter 1. Konnert and Augenstein (1990) devote an entire chapter to this idea and discuss twelve ideas that create a uniqueness within the superintendency as compared to other administrative positions within the school system. (pp. 50-56)

Konnert and Augenstein commence their discussions with the idea of scope: "The necessity to look at the big picture is paramount" (p. 50). The district superintendent is responsible for the entire operation of the school district. He/she is held accountable for the efficient and effective operation of the school district. Although there are many intricacies in the operation of any size school district, the chief administrative/executive officer is responsible for all.

Planning is also an important function of the district superintendent. "More than any other employee, the superintendent must constantly be concerned with system-wide missions and goals and must be constantly working to motivate the other employees to accept and be committed to them" (p. 51). Another aspect that contributes to the uniqueness the superintendency is **focus**. In their discussions of focus, the authors point out that district superintendents need to have a broad focus and look at the entire school district. Another important aspect that Konnert and Augenstein discuss is **decision-making**. They state that decision-making in the district superintendent milieu is extremely difficult. Often a superintendent's effectiveness is judged by his/her decisions. The exercise of this function is almost a daily routine and can be very stressful.

Konnert and Augenstein continue with a discussion of **communications**; "the superintendent must be extremely precise in his/her communications" (p.52). An effective district superintendent should be an effective communicator.

The **management** of time can also be a difficult task for administrators. A district superintendent should not have his calendar "crammed non-stop with meetings" (p.55). His work time must be allocated in such a manner as to allow time for thinking and perusal.

Konnert and Augenstein also discuss such issues as residency, longevity, fiscal expertise, levy campaigns, labour relations and lobbying. They conclude their discussions of the uniqueness of the superintendency by stating: "Any experience one

can gain prior to obtaining a superintendency in assuming decision-making responsibilities that are public and have an impact on individuals with diverse interests will be beneficial" (p. 56).

District superintendents are therefore responsible for major decisions which have to do with the district's organization and curriculum. There are many pressures on the district superintendent.

Importance of Educational Planning

As with any position of authority, the specifics of the role are often added to or deleted from depending on the size of the school district. Blumberg (1985) points out the many skills required of a district superintendent when he quotes an advertisement from the City of Gloversville, New York:

"The new superintendent must have the skills required to manage and lead a complex public educational organization such as the City School District. Of great importance are skills in financial planning and management. Other such skills include educational program development, personnel administration, community relations, communications, school board leadership and comprehensive planning." (p. 33)

Some of the aspects were discussed earlier with Konnert and Augenstein (1990). However, it is interesting to note the inclusion of the skill of "educational program development." This idea was not discussed by the preceding authors.

The idea of having some knowledge of curriculum and curriculum planning is essential. If the influence of the district superintendent within a school district is

for the betterment of educational opportunities for the students, a major focus must be on educational programme development. Holcomb (1979) commented eloquently on this idea. He states:

"Instead of educational leaders, public school superintendents have become meeting-attenders, form filler-outers, public relations experts, and specialists at coordinating advisory committees. In too many cases this dominance of paperwork and committees means that superintendents don't have as much impact as they should on the educational program in their school systems." (p. 34)

Holcomb (1979) discusses a survey of seventeen Colorado school superintendents. Only three school superintendents had worked on curriculum or staff inservice programs or had read one major professional magazine in the past week. This amounts to a seventeen percent participation rate in programme/professional development.

"The sad conclusion from my survey and informal discussions is that most school superintendents have neither the time nor the inclination to act as the educational leader for their schools." (p. 34)

Thus, the literature suggests that, while educational programme development should be an important part of the role of district superintendents, many district superintendents are too busy with other aspects of their role. As a matter of illustration, some may be so involved with making financial decisions that they do not readily exercise leadership with regard to educational programming.

The Duties of the Newfoundland District Superintendent

The duties of the district superintendent in Newfoundland are outlined in The Schools Act (1969). Section 19 of The Schools Act states:

The duties of a Superintendent shall be to:

- (a) attend meetings of the School Board and the Executive Committee thereof;
- (b) advise and assist the School Board in exercising its powers and duties under this Act;
- (c) investigate any matter as required by the Board, and after investigation, report in writing to it on such matter;
- (d) recruit and recommend for appointment professional staff and, subject to the approval of the Board, assign them to the respective positions;
- (e) subject to the approval of the School Board, determine which school a pupil shall attend;
- (f) recommend the promotion, transfer and, subject to this Act, the termination of employment of professional employees of the School Board;
- (g) develop and implement a program of supervision and inservice training;
- (h) exercise general supervision over all schools, property, teachers and, subject to subsection (2) of Section 15, other employees of the School Board and, to that end, ensure that each school is visited as frequently as feasible and at least twice in each school year.
- (i) in conjunction with the school principals and Board Supervisors concerned, articulate the programs in the elementary and secondary school grades and develop policies for promoting pupils from one school level to another;

- (j) provide leadership in evaluating and improving the educational program in the district;
- (k) provide professional advice to the School Board on planning new buildings, extensions and renovation;
- (l) assist the School Board in preparing its annual budget;
- (m) act as a means of communication between the School Board and staff, both professional and non-professional, and other employees of the School Board;
- (n) subject to the approval of the School Board, attend institutes as required by the Minister;
- (o) make known to the public the policies of the School Board and enlist support of the public for the School Board's program;
- (p) make, on forms prescribed by the Minister, annual reports to the School Board and to the Department on the educational program in the School Board's district and furnish copies of such reports to the appropriate Education Council; and
- (q) perform such other duties as may be assigned to him from time to time by the School Board, provided, however, that these duties are consistent with this Act.

An analysis of this role description, particularly items (g) and (j) could lead one to believe that Newfoundland district superintendents are to have an involvement in educational programming and/or curriculum improvements. The extent of this involvement lies largely with the district superintendent him/herself. Whether this involvement means the delegation of tasks or "hands-on" involvement once again depends on the individual.

In looking at this very specific job description of a Newfoundland district superintendent, it is very easy to see the many facets of the position. Although the position is chiefly administrative, a district superintendent is expected to be involved in curriculum development. Item (j) is quite clear. It states that Newfoundland district superintendents should "provide leadership in evaluating and improving the educational program in the district."

One can clearly see, however, the connection between the Newfoundland district superintendent's role and the aspects of uniqueness as outlined by Konnert and Augenstein (1990). The ideas of planning, communicating and decision-making are integral and specific aspects of the district superintendent's role. In addition, these characteristics seem to be stressed through the body of literature available on school district superintendents.

A final note on the specific Newfoundland role descriptions is item (q). This duty represents a very open and general "requirement" of the district superintendent. School boards and school board members may use this item to their advantage, giving the superintendent wide powers, and maybe to their district superintendent's disadvantage by giving too broad responsibilities in his or her job. It is, indeed, a very general description of "a duty," and suggests that the authority of the school board is of considerable importance.

The District Superintendent and Second/Foreign Language Study

As mentioned previously, there have been no Canadian studies focusing primarily on the role of the district superintendent and the process of implementation of French programmes.

This section includes a discussion of three American studies dealing with school/school district administrators and foreign languages. Since this literature is largely American, "foreign" is used to denote a second language, and school superintendent is used synonymously with district superintendent.

All the researchers were investigating whether district superintendents thought the study of a second language was important or not, in this case, in the light of declining enrolments in the area of second language study. The researchers hoped to find some general characteristics of district superintendents which would help to identify those who supported foreign/second language study.

The DeFilippis Study

DeFilippis (1979) conducted a survey of secondary school superintendents in western Pennsylvania. His aims were to determine the general attitude toward foreign language study at the secondary and college levels, to assess the forces operating within the secondary schools which deter foreign language study and to try and find reasons supporting the study of a foreign language.

From the very beginning DeFilippis knew that enrolments in foreign language courses at the college level had decreased between 1969 and 1974. As a matter of

illustration, he indicated that French enrolments had decreased by 34.8 percent. There were similarities at the secondary level (grades 7-12) where French enrolments had dropped by 25.6 percent. DeFilippis also cited percentages of decline of other foreign languages.

In addition to the discussion regarding enrolment declines, DeFilippis indicated that, in general, foreign language programmes had virtually disappeared from the elementary, middle and junior high schools. He states:

"All too often it was felt that they were an added 'frill' - something akin to art and music - that the district could do without. In many cases these decisions were made by the school superintendent, taking his cues from the colleges and universities which, during the late sixties and early seventies, eliminated foreign language requirements." (p. 140)

In an attempt to ascertain the opinions of school superintendents towards foreign language study, a questionnaire was sent at random to sixty school districts in western Pennsylvania. Forty-two questionnaires were returned, or seventy percent. The findings of his study indicated that district superintendents did not place a high value on the study of foreign languages either in the secondary schools or colleges. As a matter of illustration, DeFilippis found that 87.7 percent of district superintendents indicated that foreign language study was declining in their schools districts, and furthermore, 35.7 percent felt that it would continue to decline.

DeFilippis indicated that he felt some re-education of secondary schools superintendents on the merits of foreign language study was necessary.

The Weatherford Study

In another study, Weatherford (1982) conducted a survey of superintendents and high school principals in Georgia to determine the attitude towards foreign language study. As with DeFilippis (1979), Weatherford (1982) prefaced his survey results by stating that, "as in other areas of the country, foreign language enrolments have been on the decline in Georgia at all levels of instruction - elementary, high school and college." (p. 29)

The instrument used was an adapted version of the DeFilippis survey. Weatherford, however, sent the questionnaire to all district superintendents in Georgia and also to all high school principals in Georgia (187 district superintendents and 347 high school principals). Of those sent, 57.2 percent of superintendents and 50.4 percent of principals responded.

Weatherford drew several conclusions from his study. Among them was the idea that although many administrators in Georgia had never studied a foreign language, most of those who did "found language study to be a very satisfying and valuable experience" (p. 33). Another point was that there was universal agreement that the decline in foreign language study was a negative feature, and most respondents favoured efforts to counteract this decline. One can see from these observations that although many administrators had never studied a foreign language, there was some support for second language study.

Also among Weatherford's findings was the widespread support for requiring certain students to study a foreign language in high school and also support for some sort of language requirement in university. ". . . nearly a third of the principals and a fifth of the superintendents favouring language study as a college admission requirement." (p. 33)

Weatherford's final conclusion, and perhaps the most important, is stated as follows:

"Based on all this evidence, it is entirely appropriate to conclude that there is widespread, even though not universal, support for foreign language study among district superintendents and high school principals in Georgia." (p. 33)

The Beard Study

Another study conducted in the state of Illinois describes the attitudes of public secondary school superintendents and guidance counsellors toward the study of foreign languages. Beard (1984) randomly sampled 300 educators (150 superintendents and 150 guidance counsellors) from the public high school districts and the upper division of the unit school districts (grades 9-12) in the state of Illinois.

The author received responses from 244 educators or 81.33 percent. "There was a return of 125 (83.33 percent) questionnaires from the counsellors and a return of 119 (79.33 percent) questionnaires from the superintendents" (p. 30). According to Beard's survey, the Masters level was the **minimum** professional training of the

respondents, of which 72.6 percent indicated that they had studied a foreign language.

Survey results indicated that 59.8 percent of the respondents agreed that every student should be encouraged to study a foreign language. Beard, therefore, concluded that the majority of the superintendents and counselors surveyed supported the study of foreign languages in public schools. Not all, however, agreed that students should be required to study a foreign language.

An interesting finding by Beard was the fact that secondary school counsellors exhibited a more favourable attitude towards foreign languages than did school superintendents. Although Beard analyzed his entire sample as "one", he also did a cross-analysis to determine the differences between the two groups in the sample.

Beard sent his questionnaires to both urban and suburban school districts. The school districts also varied in size from the very large to small, and they also represented different geographical areas in the state of Illinois (p. 29). Another interesting finding from this survey was that attitudes towards foreign language study did not vary with the size of the school district.

The majority of respondents indicated that they believed that cultural understanding was the major reason for studying foreign languages. This finding is interesting, bearing in mind the current emphasis placed on communication in second/foreign language methodology.

In general, the research summarized above found that the study of a foreign/second language appeared to be valued more by those who had studied one, or several, second languages themselves. Such study was given more support when the goals were cross-cultural understanding, not just linguistic performance, and although everyone was encouraged, it was not felt that anyone should be required to study a second/foreign language.

The Canadian Context

The Canadian situation, however, is somewhat different. Canada is a bilingual country, and given the political situation, a knowledge of both Canada's official languages can be very beneficial. From an economic point of view, competence in a second language can often assist in finding employment, particularly for high school graduates. However, there still exist varying opinions on the importance of studying French as a second language in Canada. Rice (1988), in investigating the importance of core French with Newfoundland school principals, found that they had very little knowledge of existing French programs, goals and methodologies. However, similar to Weatherford (1982), Rice (1988) concluded that principals who had studied French had more understanding of its value and objectives and sympathized with the general reasons for studying French. There have been some studies of French immersion principals (Murphy, 1992; Gadoury, 1991; Dagenais, 1990), but very little written regarding district superintendents and French programmes.

The findings of studies completed with school principals can also be useful in discussing district superintendents. However, we must realize that district superintendents are looking at the "whole picture" and not just one building. Therefore, although some findings from principals may apply to these senior district administrators, others may not.

Conclusions

From the discussions dealing with the roles and duties of district superintendents, one can see there is a place in the job description for curriculum matters. Whether the specifics of this role indicate a direct involvement as in leadership, or an indirect involvement as in support, depends to a large extent on the individual interpretation of how much time should be given to this aspect of the superintendents' tasks.

It is also apparent from Department of Education surveys that in Newfoundland school districts a variation of French programme offerings exist. There is a wide range of factors involved here. Available teacher supply, priorities on instructional time, the location of a school and parental demands in a particular locale may influence the offering of French programmes. However, decisions regarding French programme options are made on some grounds. The district superintendent, being the chief executive/administrative officer, has some responsibility for decisions made and/or not made.

This thesis investigated the views and characteristics of Newfoundland district superintendents with regard to the implementation of French programmes in school districts with a view to determining the role of the district superintendent in decisions regarding French programmes.

CHAPTER 3

RESEARCH DESIGN AND METHODOLOGY

This chapter will discuss the study undertaken, the research question(s), the instrument used to collect data, the population surveyed and the procedures for data analysis.

The Study

As was indicated in Chapter 1, there are many differences existing in the French programme options offered in Newfoundland school districts, although the guidelines and curriculum materials from the Department of Education are the same for all districts. Since the role of the district superintendent is a major one, particularly in Newfoundland, it is important to look at the role of district superintendents in their decision making about French programmes.

The literature review in Chapter 2 pointed out that district superintendents have definite views on the importance of second/foreign language study. The literature also shows some relationship between participation in and support of foreign/second language study. In addition, the literature review indicated that one of the duties of the district superintendent is the implementation and improvement of curriculum as part of the delivery of educational programmes. However, the literature also indicated that the role of the district superintendent is primarily

administrative and that often the chief executive officer of the school district is not able to devote much time to the actual process of curriculum development.

In order to bring about improvement in district French programme offerings, it would appear that more should be known about the role which the district superintendent plays in decision-making about French programmes. In general, more specific knowledge of the characteristics of district superintendents and their views, particularly pertaining to the importance of second language study might be useful. More precise knowledge of how decisions about French programming are made in each district and the major external factors which influence these decisions are also necessary in order to be able to make judgements about the influence of the district superintendent on the articulation of a district French programme.

Research Questions

This study will attempt to answer the following questions: what internal and external factors related to district superintendents in Newfoundland affect their decisions regarding the administration of the French programmes in their school districts? There are several sub-questions that follow from these main research questions. They include:

1. What is the academic background of the district superintendent?
2. Has the district superintendent had any social experiences with French?

3. Has the district superintendent had any training in French, or another second language?
4. What is the attitude of the school district superintendent towards the importance of French programmes?
5. Is there a relationship between the answers to questions 1, 2, 3 and 4 and decisions made by the superintendent about French programmes.
6. What role does the district superintendent play in decisions regarding French programmes?
7. What factors does the district superintendent believe are the most important in making decisions about French programmes?
8. What importance is given to the directives which come from the Language Programmes Section of the Division of Programme Development at the Department of Education?
9. What factors can be influenced by the district superintendent?
10. What factors cannot be influenced by the district superintendent?

The Instrument

A survey instrument dealing with the characteristics and views of district superintendents related to French was developed that consisted of three sections. A copy of the instrument is attached in Appendix A. Section A of the survey dealt with the background/professional information about district superintendents. Section B concerned itself with decision-making information, and Section C provided district superintendents with some opinions about French programming with which they were asked to agree or disagree.

The survey instrument was developed by the researcher based on interviews of eight randomly chosen district superintendents, information gained from the review of the literature about the factors involved in making decisions about French programming and the general knowledge of the researcher gained from considerable experience in the field of education in the province.

The survey instrument was field-tested with eight individuals comprised of three school principals, three French programme coordinators and two assistant superintendents. Adjustments and modifications were made to the instrument as a result of this field-testing. A copy of correspondence to field testers and interviewed district superintendents is attached in Appendix B.

The Population

Owing to the fact that there were only twenty-seven district superintendents in Newfoundland, it was decided to use the total population and not a sample. A covering letter (see Appendix C) and the questionnaire were mailed to all district superintendents on October 23, 1991. By January 31, 1992, twenty-seven responses were received, giving a 100 percent response rate. However, an analysis was completed with a response rate of 88 percent. For although the questionnaire was mailed to the district superintendents and they were asked to respond, four school districts had the questionnaires completed by the assistant superintendent or the French programme coordinator. These four surveys were removed from analysis because they were not completed by district superintendents.

The frequencies of responses were recorded and mean scores calculated. This analysis permitted the development of a profile of the average respondent. The views of the average respondent were analyzed and the most frequently held views/responses were reported. Some discussion is also undertaken of the range in views/responses. Overall, the district superintendents presented such a homogeneous group that the relationships between background characteristics were not explored statistically.

Some relationships between the background/professional characteristics of district superintendents and their views on French programmes were explored. From these analyses, some conclusions were reached about the role of the district superintendent in decision making about French programmes in Newfoundland school districts.

A detailed analysis of the data collected is given in the following chapter.

CHAPTER 4

ANALYSIS OF DATA

This chapter deals with an analysis of the data collected from the completed survey instruments. The results are presented in sequence according to the four sections of the instrument, namely:

- (1) Background/Professional Information
- (2) Decision Making Information
- (3) Opinion Statements
- (4) Comments

Background/Professional Information

Table 4.1 gives a summary of the university degrees held by Newfoundland district superintendents. All B.A.(Ed.) (Primary) degrees and B.A.(Ed.) (Elementary) degrees were completed at Memorial University of Newfoundland. In addition, sixteen of the seventeen B.Ed. (High School) degrees were completed at Memorial University of Newfoundland. All respondents who indicated having completed a B.Sc. degree also indicated that the degree was conferred by Memorial University of Newfoundland. However, only eight of the thirteen B.A. degrees were completed at Memorial University of Newfoundland. Of the total number of undergraduate degrees completed by the respondents, eighty-eight percent were completed at Memorial University of Newfoundland; only twelve percent were completed elsewhere.

**Table 4.1 University Degrees of Newfoundland District Superintendents
(n = 23*)**

B.A. Ed. (Primary)	B.A. Ed. (Elem.)	B.Ed. (High School)	B.A.	B. Sc.	Graduate Degree	Other
1	1	17	13	4	22	11

* *Some respondents hold more than one undergraduate degree.*

From Table 4.1 it can be seen that twenty-two out of twenty-three district superintendents hold a graduate degree. Table 4.2 outlines the different universities attended by Newfoundland district superintendents for graduate study. Respondents were given M.Ed., M.A.Ed., and M.A.T. as possible choices in this section. Four respondents did not indicate where their graduate education degrees were completed.

**Table 4.2 Graduate University Degrees of Newfoundland District Superintendents - The Different Universities
(n = 23*)**

Memorial University of Newfoundland	University of New Brunswick	University of Ottawa	University of Toronto	St. Michael's College (Vermont)	Other
10	4	1	2	2	4

* *Some respondents hold more than one graduate degree.*

With respect to university location most district superintendents have received their degrees from MUN at the undergraduate level, with the exception of some of those with B.A. degree. At the graduate level, approximately one-half are graduates of MUN, while the others are graduates of other universities as indicated.

Classroom teaching experience of Newfoundland district superintendents is outlined in Table 4.3. Eight percent (2) of respondents had fewer than five years teaching experience, 53 percent (12) indicated they had between five and nine years teaching experience and 39 percent (9) indicated that they had ten or more years classroom teaching experience. The majority of superintendents have had less than 10 years classroom teaching experience.

Table 4.3 Classroom Teaching Experience of Newfoundland District Superintendents
(n = 23)

0 - 4 Years	5 - 9 Years	10+ Years
2	12	9

School administration experience and district office experience are presented in Tables 4.4 and 4.5 respectively. Totals could not be provided in these instances because in some cases district superintendents may have filled all of these roles at one point or another during their professional careers. As indicated in Table 4.4,

most district superintendents have had some previous administrative experience. Most frequently, this experience has been as a principal. As is indicated in Table 4.5, over one-half of the respondents have had previous experience at the district level as an Assistant/Associate Superintendent.

Table 4.4 District Superintendents' School Administration Experience

Position	Years of Experience		
	0 - 5	6 - 10	10+
Principal	8	2	6
Vice Principal	3	0	0
Teaching Principal/ Vice Principal	1	1	2
Other*	2	0	0

* Responses included: 1) Classroom teacher and; 2) Department head.

Of the twenty-three district superintendents who responded to the questionnaire, sixteen or 69 percent indicated that their district office experience was with the same school district. Seven respondents or 31 percent indicated that their district office experience was with two or three different school districts. The majority of district superintendents have had experience in the same district.

As indicated in Table 4.6, more than one-third of the respondents indicated they had less than six years experience in the position of District Superintendent.

Approximately one-fifth of those surveyed had between six and ten years experience in the position. At the same time, approximately one-third of respondents indicated they had ten years or more experience.

Table 4.5 District Office Experience of Newfoundland District Superintendents

Position	Years of Experience			Total
	0 - 5	6 - 10	10+	
Assistant/Associate Superintendent	7	4	1	12
Programme Coordinator	1	3	1	5
Other	4	0	0	4
District Supervisor	3	0	0	3
Miscellaneous	1	0	0	1

Table 4.6 District Superintendents' Years of Experience

(n = 23)

Years of Experience			Total
0 - 5	6 - 10	10+	
10	5	8	23

Table 4.7 outlines the language exposure of Newfoundland district superintendents. Fifty-two percent of respondents (12) indicated that they had studied French while at university. Forty-eight percent of respondents (11) indicated that they had studied another second language while at university. Respondents provided German, Italian, Spanish, Latin and Greek as examples of other second languages, with Latin being the most frequent. Thirty-four percent of respondents (8) indicated they had studied more than one second language.

Table 4.7 District Superintendents' Exposure to French and Other Second Languages
(n = 23)

Language	Yes	No	Total
French	12	11	23
Other	11	12	23

District superintendents' social experience outside Newfoundland is presented in Table 4.8. Totals for this table add up to more than twenty-three because any/all district superintendents could have lived/worked/studied in all the possibilities provided. The social experiences of superintendents have been primarily in Canadian provinces. Superintendents have had considerably more social experience outside Canada than in the province of Quebec. However, it is also worthwhile to note the number of respondents (7) who did not respond to any of these questions.

It may be assumed that these respondents had not had any experiences with French of an extended nature.

Table 4.8 Newfoundland District Superintendents' Social Experiences Outside Newfoundland

	New Brunswick	Quebec	Another Province	Outside Canada	Total Instances
Lived In	5	1	6	3	15
Worked In	0	1	5	3	9
Studied In	6	2	10	7	25
TOTAL	11	4	21	13	49

Ninety-five percent of respondents indicated that no members of their immediate family had a French background/origin. One respondent indicated that the family's great grandfather was from St. Malo in France. Other comments were strictly "all born in Newfoundland" or similar.

With respect to French populations existing within the boundaries of their school districts, 73 percent, or nearly three quarters, indicated that no such population existed. Twenty-six percent (6 respondents) indicated that there was a French population within their school districts. The approximate percentages for this French population ranged from 0.1 percent to 10 percent from the information provided by respondents.

Ninety-one percent of district superintendents indicated that Home and School Associations were present and active within their school districts. Forty-seven percent of respondents indicated that a Canadian Parents for French chapter was present and active within their school district boundaries, and twenty-one percent of respondents replied that a local francophone association was present and active in their school district. Thus, approximately one-half of the district superintendents have an active CPF group, and one-fifth are aware that there is a francophone association active in their districts.

From the findings of the survey a profile of the Newfoundland district superintendent may be constructed. The average respondent completed his undergraduate degree, most frequently a Bachelor of Arts degree, at Memorial University of Newfoundland and his graduate degree at a university outside of the province. The average respondent was also trained to teach at the high school level. The average district superintendent has had between five and nine years of classroom teaching experience, has had experience as a principal and has had district office experience as an assistant/associate superintendent before occupying the position of district superintendent. These positions have all been with the same district. The average respondent has held the position of district superintendent for five years or less.

The average Newfoundland district superintendent has had some social experiences in another Canadian province, but not in a francophone or bilingual

milieu. The average respondent has studied French in school, but has not had any close associations/friendships with francophones. The average district superintendent is familiar with Home and School Associations, but not with Canadian Parents for French or the Fédération des francophones de Terre-Neuve et du Labrador. These results suggest that the Newfoundland district superintendent is very much oriented to Newfoundland and to the geographic area where he has spent most of his life and career.

Decision-Making Information

With regard to involvement in the process of curriculum implementation for French programmes, only 13 percent of respondents indicated that they were actively involved in the process. That is to say, these district superintendents see themselves as directly involved with French curriculum implementation initiatives. However, 73 percent of Newfoundland district superintendents indicated that they facilitate the process of French curriculum implementation. One respondent indicated that,

- I am actively encouraging and facilitating the introduction of primary French in our district.

Another commented,

- I try to organize personnel, programme and support materials for the programme.

In addition, 17 percent of respondents indicated that they maintain an awareness of French curriculum implementation. These numbers do not total 100 percent because

some respondents gave more than one response to this question. In these instances respondents indicated that they are actively involved in the process and also facilitate the process. One district superintendent's involvement is summarized as follows:

- I try to organize personnel and support materials only for the French programme.

Role of French Programme Coordinator

Twenty-one percent, or approximately one-fifth of respondents indicated that their school district does not have the services of a French Programme Coordinator. As one district superintendent so aptly put it, "... this is my position - by default." Other comments relating to the vacancy of French Programme Coordinator positions included:

- Our programmes are coordinated by the Math/Science Coordinator as part of his duties.
- I don't have a full-time French Coordinator. The Religious Education Consultant acts as a liaison between the Department of Education and schools.
- The Assistant Superintendent and myself try to put as much French as possible in the schools.

In dealing with the role of the French Programme Coordinator in their school districts, 17 percent, or nearly one-fifth, of respondents indicated that the French Programme Coordinator makes decisions regarding the process of French curriculum implementation. Eighty-two percent of the district superintendents viewed their French Programme Coordinator as actively participating in decision making

regarding the French curriculum implementation process. Twenty-three percent of respondents indicated that both roles apply in their school districts; that the French Programme Coordinator makes decisions and is actively involved in decision-making.

One respondent made the following comment:

- I consider the role of the French Programme Coordinator in a staff context; but it is a leadership, influential role within the whole sphere of curriculum development and implementation.

Another district superintendent commented:

- The French Programme Coordinator is very much involved in decision making and is also an innovator.

Eight percent of respondents saw their French Programme Coordinator as giving advice only on matters of French curriculum implementation. One respondent indicated that the French Programme Coordinator maintained an awareness of French programme developments only.

Inservice Activities

The views of district superintendents on their involvement in inservice sessions is outlined in Table 4.9. As can be seen from this table, the majority of respondents indicated that they are "sometimes" involved in inservice activities.

**Table 4.9 District Superintendent Involvement In Inservice Sessions
(n=23)**

	Always	Sometimes	Never	No Response	Total
n	2	17	2	2	23
%	8.5	74.5	8.5	8.5	100

For those who responded "sometimes" to the question as to whether they are involved in French Second Language and Early/Late French Immersion inservice sessions, the majority gave two reasons why they are not involved on a regular basis. First of all, a large number of these respondents indicated that they have a French Programme Coordinator. Also, the majority of these respondents indicated that they needed to be informed only of new developments. In addition, it is worthwhile to note that no respondent, in either the "always", "sometimes" or "never" category, indicated that he/she was too busy to be involved in inservice sessions.

Some comments from district superintendents included:

- My role is a supportive one.
- I may be called upon for advice/decisions to show I support this curriculum area.

Department of Education Guidelines

In dealing with Department of Education guidelines concerning curriculum issues, 56 percent of respondents agreed that they accepted these "guidelines" as

recommendations to be followed as closely as possible. One respondent indicated,

- It depends on your meaning of guidelines. In most cases implementation is a district responsibility.

No respondent agreed that these guidelines were "rules" to be strictly adhered to.

The remaining respondents, 44 percent, agreed with the idea that these were suggested guidelines to follow.

Ninety-six percent of respondents agreed with the idea that school districts should have some freedom to develop local French programmes. A variety of reasons were provided as to why this should be; they included:

- To match local needs.
- Ownership of curriculum planning at the local level is imperative! Classroom teachers (i.e., grass roots levels) should be directly involved in French programming with District and Department guidelines.
- There should always be a mechanism to develop programmes to meet local levels.
- This would be beneficial in an area having a French population. Local courses and input are important for their relevancy to local history, customs, etc.

The one respondent who did not agree with having the freedom to develop local courses provided the following comment to support his stand:

- We must be able to surpass standards before we go our own way. There is additional personnel at the Department - I want their support and additional resources available before we could go further.

French Programme Implementation

As indicated in Table 4.10, an analysis of the problems associated with implementing French programmes clearly shows teacher supply to be the main concern. Eighteen respondents indicated this. Also, thirteen respondents indicated finances as a major problem. Six respondents indicated both teacher supply and finances; only three respondents gave other reasons and three respondents failed to respond.

Table 4.10 Problems in Implementing French Programmes

Finances	Teacher Supply	Other	Finances and Teacher Supply	No Response
13	18	3	6	3

Bearing in mind that the common problems associated with implementing French programmes were both teacher supply and finances, the respondents had interesting remarks/comments, such as:

- Difficult to get qualified teacher in remote areas.
- Not enough regular teachers have French in their training.
- There is a definite need for pre-service and inservice.

In questioning district superintendents on their predicted future trend for French study in their school district, the majority indicated that it will remain the

same. One reason given for this includes:

- I hope it will increase but teacher allocations, especially in small schools, have a negative impact.

The Role of French in the Curriculum

Fifty-two percent of respondents disagreed with the fact that French should be made a compulsory subject for all students. In addition, all of those who disagreed with this unanimously agreed that only those students who elect to study French should do so. One respondent summarized his comments as follows:

- Research indicates some individuals will never learn a second language, just as some will never learn to play the saxophone.

Another wrote:

- I believe as many students as possible should do French. It may not be possible for every single one.

In continuing the discussion for the "need" of French in our society, the district superintendents were asked whether or not they believed that French will become one of the requirements for admission to university. Eighty-three percent indicated "no", that it would not. A variety of comments were provided by this group. They included:

- Such a move would be more political than sensible.
- Culture and language, like religion, should be promoted by those who prize them and funded by the same sources.
- It should be! But never will!

- How about German and Italian?

One respondent, however, indicated yes and commented:

- It should be in a country indigenous to both French and English.

Respondents were asked to rank in priority order the major reasons for studying French. Table 4.11 outlines the results obtained. In each of the five possible responses, the range was from one (most important) to five (least important). The major reasons are presented in an abbreviated form in Table 4.11; the complete wording can be found in Section C of the questionnaire, which is included in Appendix A.

Table 4.11 Main Reasons for Studying French

Statement	Mean	Range
culture/customs . . .	2.04	1 - 5
national understanding . . .	2.87	1 - 5
cognitive development . . .	2.78	1 - 5
enhance employment . . .	3.04	1 - 5
benefit travel/leisure . . .	3.91	1 - 5

Among district superintendents, it was clear that the major reason for studying French was to help students understand another culture and set of customs. The remaining rankings can be seen in Table 4.11.

District superintendents were asked to prioritize knowledge of/proficiency in various subject areas for the students in their districts. The mean and range results are presented in Table 4.12. When responding to the questions, respondents were informed that one meant most important, while six meant least important.

Table 4.12 Knowledge of/Proficiency in Subject Area Ratings

Subject Area	Mean	Range
Reading and Writing Skills	1.17	1 - 3
Mathematics	1.98	1 - 4
Science	2.89	2 - 5
Social Sciences	3.74	2 - 5
Religious Education	4.02	1 - 6
Second Language/French	4.41	3 - 6

Respondents had a lot of difficulty with ranking these subject areas. However, most respondents seemed to place second language/French below others. One respondent decided to omit this question altogether. Two other respondents agreed with the proficiency in reading and writing, but did not rank the others. Some very interesting comments to this questions were also provided. These include:

- Unfair question - there has to be a balance.
- Religious Education should not be in the ranking because this should be a philosophy from which other things emanate.

- Hopefully our objective is to develop life-long learners with broad abilities.
- Knowledge of French culture and knowledge of French language is necessary in a bilingual country. Proficiency in French should be a matter of personal interest and choice.

Section C of the survey instrument included ten opinion statements with comments about the role of French in the curriculum. Respondents were asked to agree and/or disagree with the statements. The results of this question are given in Table 4.13. Opinion statement numbers with key words are given in the table; the complete opinion statement can be found in Section C of the questionnaire, which is included in Appendix A.

Respondents unanimously agreed with one of the ten opinion statements. First, all respondents agreed that a knowledge of French can enhance job opportunities in today's society (statement number 9). In addition, all but one respondent agreed that French programmes should endeavour to develop communication skills in the second language. One respondent omitted a response to this opinion statement. These responses indicate that district superintendents are aware of some benefits of, and current approaches to, French education.

Table 4.13 Opinion Statement Responses.

Statement Number/ Key Words	% Agree	% Disagree	% No Response
1. (same emphasis . . .)	48	52	0
2. (grammar/translation . . .)	0	96	4
3. (extended core more feasible . . .)	91	9	0
4. (broadens horizons . . .)	91	9	0
5. (co-op learning . . .)	96	4	0
6. (F.I. high achievers . . .)	4	96	0
7. (develop communication . . .)	96	0	4
8. (all schools - core French . . .)	65	30	4
9. (jobs . . .)	100	0	0
10. (F.I. a right . . .)	26	66	8

A majority of respondents agreed with opinion statements 3, 4 and 5. These three statements touch on three different issues, but most respondents did agree with them. The largest percent/area of agreement was with statement 5 which suggested that group work and cooperative learning are useful methodologies for learning French. Statement 3 dealt with extended core French being a more feasible option than French immersion and statement 4 stated that learning French broadens one's horizons and helps to develop a well-rounded person.

There was nearly unanimous disagreement with opinion statement number 2. All respondents but one, who neglected to provide any response, disagreed with the

idea that the main emphasis in teaching French should be on grammar rules and translation.

All but one respondent disagreed with the idea that French immersion programmes are only for those expected to be high achievers. At the same time, two-thirds of respondents disagreed with the idea that all children have a right to French immersion education (statement number 10). Two-thirds of respondents agreed that core French can be offered in every school in a district (statement number 8).

The most interesting response was to opinion statement number 1. The statement read, "French should have the same emphasis in our curriculum as the other subject areas." Fifty-two percent of respondents disagreed with this statement. Although this is not an overwhelming majority, it is none-the-less a majority (more than half!).

From these opinion statement responses, it can be seen that district superintendents have a good perspective on French education. They support the importance of communication skills in learning French while at the same time do not see grammar/translation as a practical methodology. They also realize the value of cooperative learning techniques. Respondents indicated that a knowledge of the French language can enhance job opportunities and broaden horizons.

For the most part, respondents realize that French immersion is not a right and is not just for the high achiever. District superintendents felt that expanded core French is a more feasible option than French immersion and approximately two-thirds of respondents feel that core French can be offered in all schools. However, a number of respondents also agreed that French is not as important as the other subject areas listed in the questionnaire.

Relationships Between Background Characteristics and Views of District Superintendents

While it was intended to analyze the data for trends in decision-making related to background characteristics, the group was so homogeneous that such analysis was not required. The few areas of interest where some differences did occur (or were expected) are summarized below.

Four respondents indicated they had completed their graduate degree programmes at the University of New Brunswick. All four indicated that they had lived and studied in New Brunswick - the only officially bilingual province of Canada. It is interesting to note that each of these four respondents felt that French should be compulsory in Newfoundland schools. However, they also unanimously agreed that French should not be an admission requirement for university. Only this latter view was shared with all of the district superintendents in the province. In addition, in contrast to the majority of district superintendents, these respondents agreed that

French should have the same emphasis in our prescribed curriculum as other subject areas. When asked to rank the importance of French as a subject, these respondents ranked it four and five, above the mean response of six.

Six respondents, 26 percent, indicated that a French population existed within the boundaries of their school districts. These respondents also agreed, as did the four University of New Brunswick graduates, that French programmes should endeavour to develop communication skills in the second language.

For the entire sample of twenty-three respondents, the mean score for proficiency in French is 4.41, as can be seen in Table 4.12. For the six respondents with a French-speaking population within the boundaries of their school district, however, the mean score for the same category is 5.85. It therefore appears that the presence of francophones within the school district boundary does not bring about a higher priority on the learning of French and the ability to communicate in French.

A point worth mentioning here is the apparent relationship between some district superintendents and the francophone population in Newfoundland. One school district failed to indicate that a French-speaking population existed within district boundaries. In three other situations the district superintendents of school districts with overlapping boundaries failed to indicate the existence of a francophone population when their counterparts of the other denomination did. In one particular case, one respondent indicated that the francophone population within the boundaries of his school district attended schools of the other denomination.

However, the district superintendent of "the other denomination" indicated there was no French-speaking population within his boundaries. These findings suggest that in general district superintendents in Newfoundland are not aware of a francophone population within their district boundaries, when they are not required to provide schooling for them.

Fifty-two percent of respondents (12) indicated that they had studied French while at university. These respondents all agreed that French programmes should develop communication skills. They also agreed with the idea that studying French helps broaden one's horizons and develops a well-rounded person. However, other respondents who had not studied French also had these views. For the group who had studied French as a second language, there was no agreement on the idea that French should be compulsory in schools nor were there any similarities in the ranking of French as compared to other subject areas. The study of French, therefore, was not a characteristic that influenced the views of district superintendents or distinguished them from other district superintendents with respect to the importance of French in the curriculum.

There were no similarities in responses amongst the forty-eight percent of respondents who indicated they had not studied French while at university which would distinguish them as a separate group.

There were seven respondents who indicated that their district office experience was with two or three different school districts. Once again, there were

no similarities to report amongst this group of respondents that would distinguish them as a group.

The Newfoundland district superintendent appears to have limited experience elsewhere, and little experience with using French. The lack of practical knowledge of (or experiences with) French seems to influence decisions of the district superintendent about French much more than does the relatively more limited experience of having studied French as a second language in school. The Newfoundland district superintendent appears to be very ethnocentric in his orientation, a characteristic which maybe reinforced by his training.

The district superintendent in Newfoundland appears to make some decisions regarding French programmes. French appears to be placed below the other subject areas listed in the questionnaire for many district superintendents, and this priority decision affects the deployment of resources within the school system. Most district superintendents leave actual decisions regarding details of programming to their French programme coordinators. Most of them do, however, seem to be aware of the developments and the changes that are taking place or have occurred in French programmes in the province, such as the use of communicative approaches and cooperative learning strategies.

The study's findings will be discussed further in Chapter 5.

CHAPTER 5

SUMMARY, CONCLUSIONS AND RECOMMENDATIONS

Summary

The study was undertaken to determine what internal and external factors influence decisions that district superintendents may make concerning the French programmes in their school districts. The position of district superintendent in Newfoundland as chief executive officer of the school district gives considerable power/authority to one individual. The writer wished to investigate whether this influence extended to educational programming, specifically French programming, bearing in mind that curriculum is provided to school districts from the provincial Department of Education.

A survey instrument was developed after several district superintendents were interviewed. The instrument consisted of four sections:

1. This first section gathered data on the background/professional information of the respondents.
2. Section B was a collection of questions that focused on decision-making information.
3. In Section C, respondents were given a number of opinion statements and were asked to agree or disagree with them.
4. The last section simply asked for any comments the respondents wanted to supply.

This survey instrument was sent to all twenty-seven district superintendents in the fall of 1991. By early spring 1992, there was a 100 percent response rate, but four of these surveys were not completed by district superintendents.

Data received were tabulated, and the characteristics and views of respondents were recorded. These findings were then reviewed to see if there were any relationships amongst the background and professional characteristics of the district superintendents and their responses to the other questions. There was less variation in characteristics and views amongst the group than had been anticipated. Data were also reviewed to determine what extent district superintendents made decisions about French programmes and what external factors appear to influence the decisions made.

Conclusions

The population surveyed was a very homogeneous group; the twenty-three district superintendents have very similar background characteristics. The findings of the study show that district superintendents are basically Newfoundland "born and bred". They have studied outside Newfoundland generally for a brief period of time at the graduate level, generally in a monolingual milieu. For most district superintendents, there is little in their background that would develop an appreciation of a need for French. The study of French for a short period of time, primarily as an educational requirement, does not appear to have much effect on their perception of the value of studying French or any second language. The

survey results indicate that district superintendents have not had a great deal of social experience in a French milieu and the general profile paints a picture of an individual who has spent his career, and life in general, in the province of Newfoundland.

The respondents who completed their graduate degrees at the University of New Brunswick appear to be more aware of French and the role of (or need for) French language programmes. These four individuals, who spent some time in Canada's only bilingual province, seem to place the importance of studying French at a higher level than do the others. It is also interesting to note that three of these four respondents have French immersion programmes within their school districts.

The perspective of the district superintendent appears to be focused on the school district where he/she has spent most of his/her career. It is very interesting to note that seven district superintendents reported a francophone population within their school district boundaries, while some district superintendents of other denominations sharing common boundaries did not report the presence of francophones in their districts. In other words, some district superintendents are cognizant of the francophone populations within their geographic areas and others are not. This finding may occur because the district superintendents are focusing on the student population they are responsible for and not the geographical region which their school district covers.

There is also a provincial organization of francophones, the Association des francophones de Terre-Neuve et du Labrador. Although it is a provincial organization and therefore could have an interest in francophones in any school district, only a very small number of district superintendents were aware of its existence.

The findings of this study suggest that district superintendents are aware of some value of studying French. They indicate that they agree with the main reasons for studying French, such as exposing students to another culture. However, more than half of the district superintendents do not feel that French is an equally important part of the curriculum. In fact, 52 percent of respondents disagreed that French should have the same emphasis as other major subject areas in our curriculum. These district superintendents appear to be in agreement with the "rankings" of subject areas in the Department of Education's *Adjusting the Course* (1994) document. In this document, French is relegated to "secondary core", placed well back from language, science, mathematics and technology education.

The fact that some district superintendents have studied French appears to have no great impact. Support for second language study is somewhat apparent, as was the case in the Weatherford Study, but not at the cost of any other subject area.

With respect to decision-making, the group on the whole are not decision makers for French programmes. Approximately 75 percent of respondents indicated that they delegate the decision-making to French programme coordinators. The

majority of respondents indicated they are "aware" only of any inservice activities and that they had "some knowledge" of French curriculum and teaching techniques. (i.e.: communication as a goal, the use of group work, etc.) The decision-making time of district superintendents seems to be spent on items other than curriculum issues. This finding is consistent with previous research on the role of the district superintendent which indicates a lack of time for curriculum issues and professional development.

However, district superintendents did indicate two major areas of concern in implementing French programmes were teacher supply and finances. These two external factors place limits on the decisions that district superintendents can make. Teachers are not always available for French programmes. Some district superintendents appear to perceive French as costing more than other subject areas.

There appears to be another external factor which influences decisions of the district superintendent although not mentioned by the respondents. This factor relates to the role of the school board. The district superintendent acts on behalf of the board and it may be that members of the board do not strongly support French programmes. As was indicated in the Policy Advisory Committee Report (1986) of the Newfoundland Department of Education:

"Newfoundland is generally thought of as being primarily anglophone. Consequently, the relevance of French to the pupils in the schools of the province is sometimes questioned." (p. 6)

Research Questions: Finding

On pages 31 and 32 of Chapter 2, ten research questions were raised concerning this study. Analysis of the responses to the questionnaire suggests the following answers to these questions:

1. What is the academic background of the district superintendent?
 - The average respondent holds a B.A. degree as an undergraduate degree, is high school trained and also holds a graduate degree in educational administration.
2. Has the district superintendent had any social experiences with French?
 - The majority have not had any social contact with francophones.
3. Has the district superintendent had any training in French or another second language?
 - Fifty-two percent of respondents indicated that they have studied French.
 - The remaining 48 percent indicated they have studied another second language.
4. What is the attitude of the school district superintendent towards the importance of French programmes?
 - For the majority of district superintendents, French is ranked as sixth in importance of the six areas listed in the questionnaire.
5. Is there a relationship between the answers to questions 1, 2, 3 and 4 and decisions made by the superintendent about French programmes?
 - There may be some relationships:

- District superintendents have limited study outside the province and virtually no experiences in a French-speaking milieu or contact with francophones. These factors seem to affect the relatively low importance district superintendents attach to the study of French.
 - Academic or required study of French alone does not appear to be sufficient to change views of the importance of French in a very monolingual society. Time spent in a French-speaking milieu or contact with francophones, however, appears to make a bigger difference than second language study alone.
6. What role does the district superintendent play in decisions regarding French programmes?
- District superintendents ultimately decide on the overall place of French within the curriculum. They decide on the priority to be given to French.
 - Beyond this, most have little role in actual curriculum development and/or curriculum implementation.
7. What factors does the district superintendent believe are the most important in making decisions about French programmes?
- District superintendents view the overall needs of their school district as the most important factor.
 - District superintendents view teacher allocations/qualifications and finances to be influencing factors.
8. What importance is given to the directives which come from the Language Programmes Section of the Division of Programme Development at the Department of Education?
- These directives are seen as guidelines and are generally implemented through the efforts of French programme coordinators or those district level personnel responsible for French.
 - The amount of instructional time given to French seems to vary with the priority placed on French at the district level.

9. What factors can be influenced by the district superintendent?
- The district superintendent can influence teacher deployment; however, he/she is very much constrained by the limitations put on him/her by the Department of Education teacher allocations, particularly in small schools.
 - The district superintendent can influence the distribution of finances.
 - The district superintendent can influence the overall development of curriculum within his/her school district.
10. What factors cannot be influenced by the district superintendent?
- The decisions of district superintendents are influenced by their backgrounds and social/educational experiences.
 - The district superintendents have no direct influence on the teacher training programmes at Memorial University which do not prepare most elementary teachers to teach French.
 - The district superintendents have no direct impact on the teacher allocation formula developed at the Department of Education.
 - The district superintendent cannot directly influence the attitude of the clientele he/she serves.

Related Questions: Answers

On pages 4 and 5 of Chapter 1, six related questions were raised. The findings of this survey would indicate the following:

1. Why do different school districts have a variation in instructional time allocated to core French?
 - There are different priorities in different districts.
 - District superintendents generally rate French as their lowest priority in comparison to other subject areas.
 - The availability of qualified teachers also varies.

2. Why is there a wide variety of French programmes existing within our province?
 - Priorities, pressures and perceived needs vary according to the clientele in different school districts.
 - Directives from the Department of Education are viewed as guidelines only.
3. Why do some school districts not have a French programme coordinator?
 - It appears that in these school districts, French is not seen as important as other needs in the district.
 - It is not always possible to attract qualified personnel.
4. Why do some school districts have only a core French programme?
 - It appears that this is so because there is no demand to do otherwise. All district superintendents agreed that extended French was a more viable option than French immersion, for example.
 - It is seen as responding to the need.
 - A high degree of competence in French is not seen as necessary.
5. Why do some school districts have early/late French immersion programmes?
 - Where the district superintendent sees value in a high degree of competence in French, he may facilitate the implementation of the programmes.
 - The district superintendent may be responding to the expressed/perceived needs of the school district.
6. Who (and what) influences decisions regarding French programmes at the district level?
 - The district superintendent has an overall influence.
 - The French programme coordinator has some influence at the classroom level.

- The availability of teachers and French programme coordinators is limited.
- According to the perception of some district superintendents, there are not adequate finances for French.
- It may be that the perception of the members of the school board as to the importance of French in the school district has an indirect effect.

Further Comment on Particular Issues

In response to the question, "What is the role of the district superintendent re French programming?" a number of inferences/comments may be made. The basic decision is the importance which is attached to the need for French programmes in the curriculum. The extent to which guidelines from the Language Programmes Section of the Department of Education are implemented depends primarily on this decision.

The detailed decisions regarding the practical implementation within the classroom affecting such aspects as resources, teaching strategies and so forth, appear to be made by the programme coordinator who is responsible for French at the district office. The district superintendent plays a general supervisory role with respect to curriculum, keeping informed of developments and facilitating their implementation to the extent that they appear to be appropriate to, and feasible in, the district.

In making decisions about French programmes, district superintendents appear to be constrained by two major factors: teaching supply and finances.

Adequately trained teachers, for a variety of reasons pertaining to teacher training, teacher allocation formula, and the geographic location of the school district, are not always available. District superintendents are also constrained by lack of money. There are limited financial resources available in any school district, based on provincial grants, and these resources must be spread over a wide variety of needs. Therefore, the district superintendent, in his capacity as CEO, must assign priorities, and the priority generally assigned to French in some districts, but not all, may restrict the implementation of the programmes.

The existence of some variations in the priority assigned to French across the province is partially explained by the considerable geographical and sociological differences between school districts. Size and location of school districts affect finances, and other resources such as teacher supply. Parental characteristics also vary widely from rural to urban areas and affect perceived needs and priorities within a district.

The district superintendent, as CEO, is ultimately responsible for the priority attached to French within the district. However, the decision is not just a personal one as he/she does not act in isolation from the community/milieu in which he/she works. While some background characteristics, notably social experience with French, appear to influence somewhat the priority attached to French by the district superintendent, he/she appears also to be influenced in making decisions about French by the general views of parents in the school district, strongly expressed views of school board members, strongly express views of district staff personnel, and the

general directives/guidelines emanating from the Department of Education which place French as "secondary core".

The results of this survey suggest that improvements in French education within Newfoundland and Labrador are largely the results of dedicated French programme coordinators working with supportive district staff at the various school district offices. If programme coordinators are eliminated, French programming will most likely be weakened. If further improvements are to occur, the effects of the external factors will have to be examined and district superintendents encouraged to review the internal factors which influence their decision-making process.

Recommendations for Action

From Study

1. In an effort to be more effective and efficient in the daily educational operations of this province, the author recommends that the results of this study be shared with all district superintendents in Newfoundland.
2. District superintendents should take the results of this study as self-hidden advice. All these individuals are well-educated, intelligent and hard-working individuals with the interest of students at heart. They should be more fully aware of the extent of their influence on programmes offered in their school districts or the educational opportunities of the students.
3. Implementation of French programmes will not be improved unless these programmes are seen as part of a whole curriculum. An overall policy needs to be developed by all those who have an interest in French education, including the district superintendents, also including the Department of Education and Memorial University's Faculty of Education.

4. The difficulty of obtaining appropriate qualified teachers of French at the elementary school level should be brought to the attention of the Faculty of Education at Memorial University of Newfoundland with a view to ensuring that steps are taken to provide all elementary teachers with the skills and training necessary to teach French.
5. The difficulty of offering French with current teacher allocation formula should be explored with the Department of Education.
6. The Modern Languages Council of the Newfoundland and Labrador Teachers' Association, the Newfoundland and Labrador Chapter of Canadian Parents for French and other agencies interested in French education should arrange a major public conference to provide a forum for discussion of the value of second language study.

For Further Study

It is the author's intention that this study provide an increased understanding of French programmes and the role of the school district superintendents in their implementation. However, the author is cognizant that more research in this area is essential.

Specifically, further research could deal with the following:

1. A follow-up study of Newfoundland district superintendents to evaluate the results of this study which would endeavour to find out in what ways district superintendents can bring about change.
2. A similar comparative study could be carried out in other provinces and territories of Canada.
3. A study of the financing of French education in the province should be undertaken to determine its importance in offering French programmes.
4. A follow-up study of the role of the school board in influencing decisions affecting French programmes would be interesting.

BIBLIOGRAPHY

BIBLIOGRAPHY

- Adjusting The Course Part I: Restructuring the School System For Educational Excellence. (1993). St. John's: Government of Newfoundland and Labrador.
- Adjusting The Course Part II: Improving The Conditions For Learning. (1994). St. John's: Government of Newfoundland and Labrador.
- American School Board Journal.(1979). Superintendent contracts should bind without choking. May 1979.
- Anderson, J. (1990). Governance for Minority Language Schools. The Canadian School Executive, May 1990, 24-27.
- Augenstein, J. J., Konnert, M.W. (1990). The Superintendency in the Nineties - What Superintendents and Board Members Need To Know. Lancaster: Technomic Publishing Company, Inc.
- Bartlett, C. R. (1988). Report on Primary Core French Questionnaire. St. John's: Government of Newfoundland and Labrador.
- Beard, J. L. (1984). Attitudes of Secondary School Counsellors and Superintendents toward Foreign Language Teachers: A Descriptive Study. Foreign Language Annals, 17, (1), 29-32.
- Blumberg, A., Blumberg, P. (1985). The School Superintendent - Living with Conflict. New York: Teachers College Press.
- Boich, J. W., Farquhar, R. H., Leithwood, K.A. (Eds), (1989). The Canadian School Superintendent. Toronto: OISE Press.
- Brandon, J. V. (1991). Anglophone Entitlement to French Immersion. The Canadian School Executive, April 1991, 3-7.
- Burbank, N. B. (1968). The Superintendent of Schools - His Headaches and Rewards. Danville: The Interstate Printers and Publishers, Inc.
- Burns, G., Olson, P. (1983). Politics, Class, and Happenstance: French Immersion in a Canadian Context. Interchange, 14, (1), 1-16.

- Canadian School Executive (1984). B. C. Superintendents Confront Provincial Government. May 1984, 15-17.
- Chrispeels, J. H. (1991). District Leadership in Parent Involvement: Policies and Actions in San Diego. Phi Delta Kappan, January 1991, 367-371.
- Coates, W. H. (1978). An Analysis of Actual Perceived and Desired Roles of the District School Superintendent in Newfoundland. Unpublished Masters Thesis, University of New Brunswick.
- Dagenais, D. (1990). Principal's Role in French Immersion. The Canadian School Executive, February 1990, 3-7.
- DeFelippis, D. (1979). Views of Secondary School Superintendents on Foreign Language Study: A Support-Constraint Analysis. Foreign Language Annals, 12, (2), 138-144.
- Eaton, W. E. (Ed), (1990). Shaping The Superintendency: A Re-examination of Callahan and The Cult of Efficiency. New York: Teachers College Press.
- Fullan, M. (1982). The Meaning of Educational Change. Toronto: OISE Press.
- Fullan, M., Stiegelbauer, S. (1991). The New Meaning of Educational Change. Toronto: OISE Press.
- Gadoury, G. H. (1991). Administrative concerns in French immersion schools: Response to Dagenais. The Canadian School Executive, February 1991, 3-11.
- Genge, A. (1991). Effective School Superintendents. Unpublished Doctor of Philosophy Thesis, The University of Alberta.
- Guttman, M. A. J. (1983). There's More to French Immersion Than Social Class. Interchange, 14, (1), 17-22.
- Hall, G. E., Hord, S. M., Huling-Austin, L., Rutherford, W. L. (1989). Taking Charge of Change. Alexandria: Association for Supervision and Curriculum Development.
- Herman, J. J., Kaufman, R. (1983). Organizational Success and Planning Role(s) and Perspectives of a Superintendent. Performance and Instruction Journal, October 1983.

- Holcomb, J. H. (1979). Superintendents should push programs - not paperwork. The American School Board Journal, No. 66, 34.
- Holdaway, E. A., Genge, A. (1991, June). Effective C.E.O's of School Systems. Paper presented at the Annual Conference of the Canadian Association for the Study of Educational Administration.
- Hopkins, D. (Ed.) 1987). Improving The Quality of Schooling, Lessons From the OECD International School Improvement Project. New York: The Falmer Press.
- Hord, S. M., Huling - Austin, L. (1986). Effective Curriculum Implementation: Some Promising New Insights. The Elementary School Journal, 87, (1), 97-115.
- Johnson, C. (1979). Superintendents are benched when they make these avoidable mistakes. The American School Board Journal, March 1979.
- Kate, M. (1990). The Staff Development Needs of Superintendents and Principals. Journal of Staff Development, 11, (4), 54-58.
- Kendall, V. G. (1985). The Evaluation of District Superintendents of Education in Newfoundland and Labrador. Unpublished Masters Thesis, Bishop's University.
- King, F. J. (1972). Role Pressures, Personality Characteristics and Extent of Job Satisfaction of the District Superintendent in Newfoundland. Unpublished Masters Thesis, Memorial University of Newfoundland.
- Klayman, N.E. (1975). Views of Secondary School Educators on the Foreign Language Requirement in Higher Education. The Modern Language Journal, 59, 168-173.
- McGillivray, W. R. (Ed.) (1985). More French, s'il vous plait. Ottawa: Mutual Press Ltd.
- Monkhouse, T. (1986). Human Characteristics that Facilitate Change. The Canadian School Executive, May, 1986, 9-12.
- Murphy, E. (1992). An Ethnographic Study of Problems Related to the Principalship

- of a Combined French Immersion and French Minority-Language Kindergarten to Grade Five School. Unpublished Masters Thesis, Memorial University of Newfoundland.
- Murphy, J. T. (1991). Superintendents as Saviors: From the Terminator to Pogo. Phi Delta Kappan, March 1991.
- Musella, D. (1992). The changing role of the Chief Education Officer in Canada. The Canadian School Executive, March 1992, 17-21.
- Ornstein, A. C. (1987). Planning the Curriculum In A World of Change. Curriculum Review, January/February, 1987, 22-24.
- Ortiz, F. I., Wissler, D. F. (1988). The Superintendent's Leadership in School Reform. Philadelphia: The Falmer Press.
- Pack, H. P. (1979). A Study of Factors Affecting Enrollment in French in the Senior High School: A Comparison of Variables of Sex, Achievement, Attitude and Motivation of Two Groups of Grade Ten Students. Unpublished Masters Thesis, Memorial University of Newfoundland.
- Powell, R. (1990). Superintendents: The Key Influence Agents. (Eric Document Reproduction Service No. 320 280).
- Ralph, E. (1988). The role of the district administrator in field experience programs. Education Canada, 22, (4), 14-19, 25.
- Report of the Policy Advisor Committee on French Programs. (1986). St. John's: Government of Newfoundland and Labrador.
- Rice, F. R. (1988). Newfoundland Principals' Perception of French Second Language Programs Within the School Curriculum. Unpublished Masters Thesis, Memorial University of Newfoundland.
- Schmuck, P. A. (1992). Educating the New Generation of Superintendents. Educational Leadership, 49, (5), 66-71.
- Stathem, R. L. (1987). How Fledging Superintendents can retain their rail feathers. The Executive Educator, 9, (11), 15.
- Vann, A. S. (1988). The Curriculum Cup Runeth Over. Educational Leadership,

46, (1), 60.

Wallace, R. H. (1959). The Superintendent As Educational Leader. Toronto: The Ryerson Press.

Weatherford, H. J. (1982). Foreign Language Attitudes Survey: Georgia Superintendents and High School Principals. Foreign Language Annals, 15, (1), 29-33.

Williams, R. C., Marcus M. (1982). How Do External Influence School District Management: A Preliminary Inquiry. (Eric Document Reproduction Service No. 231 018).

APPENDICES

APPENDIX A
Questionnaire

**FACTORS INFLUENCING DECISIONS
AT THE DISTRICT LEVEL
REGARDING FRENCH PROGRAMMES**

1991

NOTE: All responses will remain strictly confidential, being used as project data only.

Thank you for your assistance.

SECTION A

BACKGROUND/PROFESSIONAL INFORMATION

81

1. **UNIVERSITY DEGREE(S) HELD:**
(Please check as many as are applicable and give university name.)

UNIVERSITY

- | | | | |
|----|-------------------------------------|--------------------------|--------------|
| a) | B.A. (Ed.) (Primary) | <input type="checkbox"/> | _____ |
| b) | B.A. (Ed.) (Elementary) | <input type="checkbox"/> | _____ |
| c) | B. Ed. (High School) | <input type="checkbox"/> | _____ |
| d) | B.A. Major/Minor ___/___ | <input type="checkbox"/> | _____ |
| e) | B. Sc. Major/Minor ___/___ | <input type="checkbox"/> | _____ |
| f) | M. Ed./M.A. Ed./M.A.T. | <input type="checkbox"/> | _____ |
| g) | Other degree(s) | <input type="checkbox"/> | _____ |
| | (please specify) | | _____ |
| h) | Other diploma(s)/
certificate(s) | <input type="checkbox"/> | _____ |
| | (please specify) | | _____ |
| i) | Other post-graduate study | <input type="checkbox"/> | _____ |
| | (please specify) | | _____ |
| | and | | |
| | length of study | | _____ years. |

2. **CLASSROOM TEACHING EXPERIENCE**
(Please check appropriate box)

- | | | |
|----|---------------------|--------------------------|
| a) | Fewer than 5 years. | <input type="checkbox"/> |
| b) | 5-9 years | <input type="checkbox"/> |
| c) | 10 or more years | <input type="checkbox"/> |

3. SCHOOL ADMINISTRATION EXPERIENCE 82
- a) Principal _____ years.
- b) Vice Principal _____ years.
- c) Other (please specify) _____ years.
-

4. DISTRICT OFFICE EXPERIENCE
- a) Superintendent _____ years.
- b) Assistant/Associate Superintendent _____ years.
- c) Programme Coordinator _____ years.
- d) Other (please specify) _____ years.
-

5. a) Was all of your district office experience with the same school district?
- YES NO
- b) If no, the number of different school districts. _____

6. Have you ever studied, YES NO NO. YEARS
- a) French [] [] _____
- b) Another Second Language [] [] _____
(please specify)
-

b) What should be the role of these organizations with respect to French programmes?

Comment: _____

- | | <u>New Brun.</u> | <u>Quebec</u> | <u>Another Prov.</u> | <u>Elsewhere</u> |
|--------------------------------|--------------------------|--------------------------|--------------------------|--------------------------|
| 7. Have you ever lived in... | <input type="checkbox"/> | <input type="checkbox"/> | <input type="checkbox"/> | <input type="checkbox"/> |
| 8. Have you ever worked in... | <input type="checkbox"/> | <input type="checkbox"/> | <input type="checkbox"/> | <input type="checkbox"/> |
| 9. Have you ever studied in... | <input type="checkbox"/> | <input type="checkbox"/> | <input type="checkbox"/> | <input type="checkbox"/> |
10. Do you or any of your family members have a French background?
 YES NO
11. a) Is there a French population in or near your community?
 YES NO
- b) If yes, approximate proportion _____.
12. Are any of the following present and active in your community.
- a) Home School Associations
 - b) Canadian Parents for French
 - c) Francophone Association
13. a) What is the role of these organizations with respect to French programmes?
-
-

SECTION B

DECISION MAKING INFORMATION

1. What do you see to be your role in curriculum implementation?

- a) Active
 - b) Facilitator
 - c) Awareness of French Program Development
 - d) Other (please specify)
-

Comment: _____

2. What do you see to be the role of your French Programme Coordinator in curriculum implementation?

- a) No French Programme Coordinator
 - b) Makes decisions
 - c) Active participant in decisions
 - d) Awareness of French programme developments
 - e) Gives advice only
 - f) Other (please specify)
-

Comment: _____

3. a) Do you think you should be directly involved in French-Second-Language and Early/Late French Immersion in-service sessions?

YES NO SOMETIMES

b) Why?

- Because I have a French Programme Coordinator.
 - Because I have an Assistant/Associate Supt.
 - Because I am an Administrative Officer.
 - Because I am too busy.
 - Because I need to be informed about new developments.
 - Other (please specify)
-

4. How do you regard guidelines from the Department of Education concerning curriculum issues?

- Suggested guidelines to follow
 - Recommendations to be followed as closely as possible
 - "Rules" to be strictly adhered to
 - Other (please specify)
-
-

5. a) Should districts have the freedom to localize their French programme?

YES NO

b) Why or Why Not? _____

6. What are the greatest problems in implementing French programmes? 87

- a) Finances
- b) Teacher Supply
- c) Other identified needs
- d) Other (please specify)
-

7. How do you feel about the future trend of French study in your schools?

- a) It will decline
- b) It will remain the same
- c) It will increase

Comment: _____

8. a) Do you think French should be compulsory for all students?

YES NO

- b) If no, who should study French?

University-bound students

Students who elect it

All students?

Comment: _____

9. Do you think French will become one of the requirements for admission to university?

YES NO

Comment: _____

10. What do you feel are the major reasons for studying French?
(Please rank order with 1 being most important and 5 least important.)

- _____ For future employment/career opportunities.
- _____ For the benefit of travel/leisure time.
- _____ To promote national understanding.
- _____ To further the cognitive development of students.
- _____ To understand another culture and customs.

11. Prioritize these items for the students in your district.
(1 - most important to 6 - least important)

- _____ Knowledge of social sciences (including Newfoundland history.)
- _____ Knowledge of science
- _____ Proficiency in second language/French
- _____ Proficiency in mathematics
- _____ Reading and writing skills (mother tongue)
- _____ Religious Education knowledge

Comment: _____

SECTION C

OPINION STATEMENTS

Please circle - A for Agree or - D for Disagree.

1. French should have the same emphasis in our curriculum as the other subject areas.

A D

2. The main emphasis in teaching French should be on grammar rules and translation.

A D

3. Extended Core French is more feasible than French Immersion for most school districts in our province.

A D

4. Learning French broadens one's horizons and helps develop a well-rounded person.

A D

5. Group work and cooperative learning are useful methodologies for teaching French.

A D

6. French Immersion programmes are only for those expected to be high achievers.

A D

7. French programmes should endeavour to develop communication skills in the second language.

A D

8. Core French can be offered in every school in a school⁹⁰
district.

A

D

9. A knowledge of French can enhance job opportunities in today's
society.

A

D

10. All children have a right to French Immersion education.

A

D

APPENDIX B

**Correspondence (Field Testers/Interviewed
District Superintendents)**

November 06, 1991

Mr. Gary Young
French Programme Coordinator
Exploit's Valley Integrated School Board
P.O. Box 70, St. Catherine Street
Grand Falls, NF
A2A 2J3

Dear ~~Mr. Young:~~ Gary

I would like to take this opportunity to thank you for taking time out of your busy schedule to provide me with feedback on my thesis questionnaire. Your comments, opinions and suggestions were very beneficial to me; they resulted in several positive changes to my survey instrument.

Once again, thanks for your input. I would be glad to share the results of my survey with you should you be interested.

Sincerely,

Barry W. Rowe

BWR:dc
c.c. Prof. J. Netten

November 06, 1991

Ms. Patricia Hooper
French Programme Coordinator
Deer Lake - St. Barbe South Integrated School Board
P.O. Box 2001
Deer Lake, NF
A0K 2E0

Dear ~~Ms. Hooper:~~ *PAT*

I would like to take this opportunity to thank you for taking time out of your busy schedule to provide me with feedback on my thesis questionnaire. Your comments, opinions and suggestions were very beneficial to me; they resulted in several positive changes to my survey instrument.

Once again, thanks for your input. I would be glad to share the results of my survey with you should you be interested.

Sincerely,

Barry W. Rowe

BWR:dc
c.c. Prof. J. Netten

November 06, 1991

Mr. Gerry MacDonald
French Programme Coordinator
Humber - St. Barbe Roman Catholic School Board
P.O. Box 368
Corner Brook, NF
A2H 6G9

Dear Mr. ~~MacDonald~~: *Gerry*

I would like to take this opportunity to thank you for taking time out of your busy schedule to provide me with feedback on my thesis questionnaire. Your comments, opinions and suggestions were very beneficial to me; they resulted in several positive changes to my survey instrument.

Once again, thanks for your input. I would be glad to share the results of my survey with you should you be interested.

Sincerely,

Barry W. Rowe

BWR:dc
c.c. Prof. J. Netten

November 06, 1991

Sister Gladys Bozec
Assistant Superintendent (French Programmes)
Appalachia Roman Catholic School Board
P.O. Box 5200
Stephenville, NF
A2N 3M5

Dear Sister ^{Gladys}Bozec:

I would like to take this opportunity to thank you for taking time out of your busy schedule to provide me with feedback on my thesis questionnaire. Your comments, opinions and suggestions were very beneficial to me; they resulted in several positive changes to my survey instrument.

Once again, thanks for your input. I would be glad to share the results of my survey with you should you be interested.

Sincerely,

Barry W. Rowe

BWR:dc
c.c. Prof. J. Netten

November 06, 1991

Dr. Cluney Vincent
Principal
Dorset Collegiate
Pitiley's Island, NF
AOL 1M0

Dear ~~Dr. Vincent~~: *Cluney*

I would like to take this opportunity to thank you for taking time out of your busy schedule to provide me with feedback on my thesis questionnaire. Your comments, opinions and suggestions were very beneficial to me; they resulted in several positive changes to my survey instrument.

Once again, thanks for your input. I would be glad to share the results of my survey with you should you be interested.

Sincerely,

Barry W. Rowe

BWR:dc
c.c. Prof. J. Netten

November 06, 1991

Mr. Bruce Day
Principal
G. A. Mercer Junior High School
P. O. Box 458
Corner Brook, NF
A2H 6E6

Dear ~~Mr. Day~~: *Bruce*

I would like to take this opportunity to thank you for taking time out of your busy schedule to provide me with feedback on my thesis questionnaire. Your comments, opinions and suggestions were very beneficial to me; they resulted in several positive changes to my survey instrument.

Once again, thanks for your input. I would be glad to share the results of my survey with you should you be interested.

Sincerely,

Barry W. Rowe

BWR:dc
c.c. Prof. J. Netten

November 06, 1991

Mr. Allan Skanes
Principal
Curling Elementary School
Woodbine Ave
Corner Brook, NF
A2H 3P2

Dear Mr. ~~Skanes~~: *AL*

I would like to take this opportunity to thank you for taking time out of your busy schedule to provide me with feedback on my thesis questionnaire. Your comments, opinions and suggestions were very beneficial to me; they resulted in several positive changes to my survey instrument.

Once again, thanks for your input. I would be glad to share the results of my survey with you should you be interested.

Sincerely,

Barry W. Rowe

BWR:dc
c.c. Prof. J. Netten

63 Carter Ave.
Corner Brook, Nfld.
A2H-7E2
August 14, 1991

Mr. Randell Dawe
District Superintendent
Conception Bay South Integrated School Board
P.O. Box 220
Manuels, Conception Bay, Nfld.
A0A-2Y0

Dear Mr. Dawe:

I would like to take this opportunity to thank you for taking time out of your busy schedule on August 8, 1991 to meet with me. Your comments, opinions and suggestions will be very beneficial to me as I complete my Master of Education thesis.

Once again, thank you, and I look forward to your response to my questionnaire that will be mailed early this fall.

Sincerely,

Barry W. Rowe

cc. Prof. J. Netten

63 Carter Ave.
Corner Brook, Nfld.
A2H-7E2
August 14, 1991

Mr. William H. Coates
District Superintendent
Bay of Islands-St. Georges/Burgeo
Ramea Integrated School Board
P.O. Box 190
Corner Brook, Nfld.
A2H-6C7

Dear ~~Mr. Coates~~: *Harry*

I would like to take this opportunity to thank you for taking time out of your busy schedule on July 20, 1991 to meet with me. Your comments, opinions and suggestions will be very beneficial to me as I complete my Master of Education thesis.

Once again, thank you, and I look forward to your response to my questionnaire that will be mailed early this fall.

Sincerely,

Barry W. Rowe

cc. Prof. J. Netten

63 Carter Ave.
Corner Brook, Nfld.
A2H-7E2
August 14, 1991

Mr. Leo Whalen
District Superintendent
Humber-St. Barbe R.C. School Board
P.O. Box 368
Corner Brook, Nfld.
A2H-6G9

Dear Mr. Whalen:

I would like to take this opportunity to thank you for taking time out of your busy schedule on July 19, 1991 to meet with me. Your comments, opinions and suggestions will be very beneficial to me as I complete my Master of Education thesis.

Once again, thank you, and I look forward to your response to my questionnaire that will be mailed early this fall.

Sincerely,

Barry W. Rowe

cc. Prof. J. Netten

63 Carter Ave.
Corner Brook, Nfld.
A2H-7E2
August 20, 1991

Mr. Andrew Butt
District Superintendent
Appalachia R.C. School Board
P.O. Box 5200
Stephenville, Nfld.
A2N-3M5

Dear Mr. Butt:

I would like to take this opportunity to thank you for taking time out of your busy schedule on August 16, 1991 to meet with me. Your comments, opinions and suggestions will be very beneficial to me as I complete my Master of Education thesis.

Once again, thank you, and I look forward to your response to my questionnaire that will be mailed early this fall.

Sincerely,

Barry W. Rowe

cc. Prof. J. Netten

63 Carter Ave.
Corner Brook, Nfld.
A2H-7E2
August 29, 1991

Mr. Anthony Genge
District Superintendent
Virland/Strait of Belle Isle
Integrated School
P.O. Box 89
Flower's Cove, Nfld.
A0K-2N0

Dear Mr. Genge:

I would like to take this opportunity to thank you for taking time out of your busy schedule on August 23, 1991 to meet with me. Your comments, opinions and suggestions will be very beneficial to me as I complete my Master of Education thesis.

Once again, thank you, and I look forward to your response to my questionnaire that will be mailed early this fall.

Sincerely,

Barry W. Rowe

cc. Prof. J. Netten

63 Carter Ave.
Corner Brook, Nfld.
A2H-7E2
August 31, 1991

Mr. Graham Blundon
District Superintendent
Deer Lake-St. Barbe South
Integrated School Board
P.O. Box 2001
Deer Lake, Nfld.
A0K-2E0

Dear Mr. Blundon:

I would like to take this opportunity to thank you for taking time out of your busy schedule on August 30, 1991 to meet with me. Your comments, opinions and suggestions will be very beneficial to me as I complete my Master of Education thesis.

Once again, thank you, and I look forward to your response to my questionnaire that will be mailed early this fall.

Sincerely,

Barry W. Rowe

cc. Prof. J. Neiten

63 Carter Ave.
Corner Brook, Nfld.
A2H-7E2
August 29, 1991

Dr. G.L. Moss
District Superintendent
Green Bay Integrated School Board
P.O. Box 550
Batstone's Rd.
Springdale, Nfld.
A0J-1T0

Dear Dr. Moss:

I would like to take this opportunity to thank you for taking time out of your busy schedule on August 26, 1991 to meet with me. Your comments, opinions and suggestions will be very beneficial to me as I complete my Master of Education thesis.

Once again, thank you, and I look forward to your response to my questionnaire that will be mailed early this fall.

Sincerely,

Barry W. Rowe

cc. Prof. J. Netten

APPENDIX C
Covering Letter

63 Carter Ave.
Corner Brook, Nfld.
A2H-7E2
October 22, 1991

Dear District Superintendent:

Attached please find a questionnaire dealing with the factors influencing decisions at the district level regarding French programmes. I have developed this questionnaire to assist me in the completion of my Master of Education thesis at Memorial University of Newfoundland.

It would help me tremendously if you would take approximately twenty minutes out of your busy schedule to complete this survey. Please be assured that the information gathered will be held in the strictest confidence being used as project data only, and that personal information will be reported in a generalized manner. It is my intention to interpret this data to find ways in which school districts could be assisted in the implementation process.

Should you have any questions and/or concerns, do not hesitate to contact me at 634-0938 (home) or 639-9823 (work). I am enclosing a self-addressed stamped envelope for you to return your completed questionnaire. If you wish to receive information regarding the results of this study, would you please complete the attached form.

I would appreciate receiving your completed questionnaire by **November 26, 1991**.

I thank you in advance for your cooperation in this matter.

Sincerely,

Barry W. Rowe

cc: Prof. J. Netten

I would like to receive a copy of the results of this survey when available.

109

NAME: _____

ADDRESS: _____

TELEPHONE: _____

APPENDIX D

Correspondence (Miscellaneous)

63 Carter Ave.
Corner Brook, Nfld.
A2H-7E2
August 14, 1991

*Dr. Boyce Fradsham
Executive Director
Royal Commission on Education
187 Gower St., Victoria Hall
St. John's, Nfld.
ALA-1P9*

Dear Dr. Fradsham:

I would like to take this opportunity to thank you for taking time out of your busy schedule on July 18, 1991 to meet with me. Your comments, opinions and suggestions will be very beneficial to me as I complete my Master of Education thesis.

Once again, thank you for your assistance.

Sincerely,

Barry W. Rowe

cc. Prof. J. Netten

Faculty Committee for Ethical Review of
Research Involving Human Subjects

Certificate of Approval

Investigator: Mr. Barry Rowe

Department/Division/Institute: Faculty of Education
Memorial University of Newfoundland

Title of Research: Masters Thesis in French Education

Approval Date: September 9, 1991

The Ethics Review Committee has reviewed the protocol and procedures as described in this research proposal and we conclude that they conform to the University's guidelines for research involving human subjects.

Dr. Glenn W. Sheppard
Acting Chairman
Ethics Review Committee

Members: Dr. George Hickman, Associate Professor, Education
Dr. Miriam Yu, Professor, Education
Dr. Glenn Sheppard, Professor, Education
Dr. Amarjit Singh, Professor, Education
Dr. Lee Klas, Professor, Education

WESTERN INTEGRATED SCHOOL BOARD

P.O. Box 190, Brook Street, Corner Brook, NF A2H 6C7
Telephone: (709) 639-9823, (709) 639-9973 Fax: (709) 639-1733

113

February 17, 1992

Dr. Anthony Genge
District Superintendent
Vinland - Strait of Belle Isle
Integrated School Board
P. O. Box 89
Flower's Cove, NF
A0K 2N0

Dear Dr. Genge:

In a recent conversation with my Superintendent, Mr. Wm. H. Coates, I was informed that on March 13 you will be doing a presentation dealing with your Ph.D. dissertation to the Western Regional NLASE in Deer Lake.

Owing to the fact that my M.Ed. thesis has some similarities, I was wondering if I could sit in on your presentation. Both my Superintendent, Mr. Coates, and Mr. Robert Mesher, the session organizer, feel that it would be to my benefit to attend.

I would be appreciative of a positive response at your convenience.

I would also like to take this opportunity to thank you for completing my survey that I circulated in October, 1991.

Sincerely,

Barry W. Rowe
French Programme Coordinator

cc: Prof. J. Netten
Mr. Wm. H. Coates
Mr. Robert Mesher

BWR ib



GOVERNMENT OF NEWFOUNDLAND AND LABRADOR
DEPARTMENT OF EDUCATION

114

P. O. BOX 8700
ST. JOHN'S, NFL
A1B 4J6
Fax: #729-3896

November 24, 1992

Mr. Barry Rowe
French Program Coordinator
Western Integrated School Board
P.O. Box 190
Corner Brook, NF
A2H 6C7

Dear Mr. Rowe:

Enclosed for your information is a copy of "Education Statistics - Elementary-Secondary, 1991-92". The number of schools by school district is shown in Table 5, page 10 and the number of students by school district is shown in Table 10, page 20.

If you have any questions, please call me at 729-2992.

Sincerely,

JILL ANDREWS
Statistician
Evaluation, Research, & Planning

Enclosure

JA/cdh



