

GENERATION PARTICIPATION FACTORS AND
TRANSMISSION COSTING

CENTRE FOR NEWFOUNDLAND STUDIES

**TOTAL OF 10 PAGES ONLY
MAY BE XEROXED**

(Without Author's Permission)

CHRIS KIRBY



**GENERATION PARTICIPATION FACTORS
AND
TRANSMISSION COSTING**

by

Chris Kirby

A thesis submitted in partial fulfillment
of the requirements for the degree of
Masters of Engineering

Faculty of Engineering and Applied Science
Memorial University of Newfoundland

St. John's Newfoundland Canada

April 1998

ABSTRACT

At present, the North American electric utility industry is undergoing fundamental changes that will effect the means by which revenues are generated. One of the revenue streams that will gain importance is the transmission line tariff. Re-regulation in this industry will necessitate some means for estimating the contributions made by each system generator to the total power flow in the transmission system in order to approximate the tariff costs in advance. The existing literature dealing with tariff rate design presents only the traditional methods for attributing the current in transmission lines to their sources. One such method is the procedure of performing successive load flow studies. This thesis discusses some of the proposed toll schemes and presents a mathematical derivation for decomposing the total power flow in a transmission line into components attributable to contributing generators. The method is based on the use of the inverse admittance matrix for a system configuration and the results from load flow solutions. It has been successfully applied to a modified standard IEEE 14 bus system in an effort to evaluate its suitability for application to the many proposed tariff schemes that apportion the cost of the physical plant between users. The simulations produce satisfactory results and indicate that this simplified method is suited to the philosophy of the costing methodologies anticipated under the emerging deregulation regime. For its application, the proposed method requires only one load flow

solution for the operating point and configuration in question. The technique can be easily incorporated into system planning software as an important feature.

ACKNOWLEDGMENT

I would sincerely like to thank Professor Dr. M.A. Rahman for his exceptional support and guidance throughout my efforts in preparing this thesis. His knowledge, patience and leadership were invaluable contributions towards its creation. I would like to thank him as well for the financial support and especially for the interesting conversation that always seem to develop during my visits. I consider myself fortunate

I would as well like to thank Prof. B. Jeyasurya for his help in obtaining the required load flow software.

TABLE OF CONTENTS

ABSTRACT.....	I
ACKNOWLEDGMENT.....	III
TABLE OF CONTENTS.....	IV
LIST OF FIGURES.....	VIII
LIST OF TABLES.....	IX
LIST OF SYMBOLS.....	XI
LIST OF ABBREVIATIONS.....	XIV
CHAPTER I.....	I
ELECTRIC UTILITY REGULATORY ISSUES.....	I
1.0 INTRODUCTION.....	1
1.1 REGULATORY HISTORY.....	3
1.2 FEDERAL ENERGY REGULATORY COMMISSION RULE 888.....	6
1.2.2 STRANDED COSTS.....	7
1.2.3 RECIPROCITY.....	8
1.2.4 FLOW BASED PRICING VERSES CONTRACT PATH PRICING.....	9
1.2.5 INDEPENDENT SYSTEM OPERATORS.....	9

1.3 FUTURE STRUCTURE	11
1.3.1 GENERATION SECTOR	11
1.3.2 TRANSMISSION SECTOR	12
1.3.3 DISTRIBUTION SECTOR	14
CHAPTER 2.....	16
WHEELING COST ALLOCATION SCHEMES AND PRICING	16
2.0 INTRODUCTION	16
2.1 DISCUSSION OF TERMINOLOGY	19
2.2 PREMISE	21
2.2.1 INDUSTRY STRUCTURE	21
2.3 PRICING SCHEMES	22
2.3.1 EMBEDDED PRICING	23
2.3.1.1 Postage Stamp Allocator as applied to embedded pricing	24
2.3.1.2 Contract Path Allocator as applied to embedded pricing	24
2.3.1.3 Boundary Flow Allocator as applied to embedded pricing	25
2.3.1.4 Megawatt-Mile Allocator as it applies to embedded pricing	27
2.3.2 DISCUSSION OF THE EMBEDDED COST METHODS	32
2.3.2.1 Postage Stamp Method	32
2.3.2.2 Contract Path Methods	32
2.3.2.3 Boundary Flow Methods	33
2.3.2.4 Megawatt Mile Allocators	33
2.3.2.5 Comments on all Embedded Methods	36
2.3.3 INCREMENTAL COSTS AND PRICING	38
2.3.3.1 Short run incremental cost method	39
2.3.3.2 Long Run Incremental Costs	40
2.3.3.3 General Incremental costing concepts	41

2.3.3.4 Dollar per MW Allocator, as applied to long run incremental pricing.....	43
2.3.3.5 Dollar Per Megawatt-Mile Allocator as applied to incremental pricing.....	43
2.3.3.6 Interface Flow By Region, as it applies to long run incremental pricing.....	45
2.3.4. DISCUSSION OF THE INCREMENTAL COST METHODS.....	46
2.3.4.1 Short Run Incremental Cost Allocator.....	46
2.3.4.2 Dollar Per Megawatt Allocator.....	46
2.3.4.3 Dollar per Megawatt-Mile Allocator.....	46
2.3.4.4 Interface Flow By Region.....	47
2.3.4.5 Concluding Comments on all Incremental Methods.....	47
2.3.5 SHORT RUN MARGINAL COST ANALYSIS.....	47
2.3.6 DISCUSSION OF THE SHORT RUN MARGINAL COST METHOD.....	48
CHAPTER 3.....	50
GENERALIZED PARTICIPATION FACTORS.....	50
3.0 INTRODUCTION.....	50
3.1 SIMPLE SYSTEM.....	51
3.2 NEWTON'S METHOD.....	54
3.3 GENERATION PARTICIPATION FACTORS.....	56
3.4 LOAD PARTICIPATION FACTORS.....	66
CHAPTER 4.....	69
APPLICATION AND DISCUSSION.....	69
4.0 INTRODUCTION.....	69
4.1 TEST SYSTEM.....	69
4.2 TEST PROCEDURE.....	71
4.3 TEST RESULTS.....	77
4.3.1 POINT ONE, RADIAL FEED.....	77

4.3.2 POINT TWO, LOOP FEED	78
4.3.3 POINT THREE, COUNTER FLOW	79
4.3.4 TEST GROUP 1	79
4.3.5 TEST GROUP 2	79
4.3.6 ACCURACY OF RESULTS	80
CHAPTER 5	90
SUMMARY AND CONCLUSIONS	90
5.0 SUMMARY	90
5.1 MAJOR CONTRIBUTION OF THIS WORK	92
5.2 CONCLUSIONS	93
5.3 RECOMMENDATIONS FOR FUTURE WORKS	93
BIBLIOGRAPHY	95
IEEE 14 BUS SYSTEM AND SYSTEM DATA	APPENDIX A
RAW DATA AND LOAD FLOW SOLUTIONS	APPENDIX B
TABLES OF PARTICIPATION FACTORS, LINE AND LOAD CONTRIBUTIONS	APPENDIX C
EXCEL CELL FORMULAS	APPENDIX D

LIST OF FIGURES

<i>Figure 3.1 - Simple 3 bus system</i>	51
<i>Figure 3.2 - Simple 1 bus system</i>	55
<i>Figure 3.3 - Function</i>	55
<i>Figure 3.4 - Derivative of function inverse</i>	55
<i>Figure 4.1 - Modified IEEE 14 bus system single line diagram</i>	70
<i>Figure 4.2 - De-coupled Load Flow Flow Chart</i>	74
<i>Figure 4.3 - Participation Factor Flow Chart</i>	75
<i>Figure 4.4 - Modified Excerpt from table C.5-C, bus number 5.</i>	82
<i>Figure 4.5 - G1 Participation Factors for Studies 1 -3</i>	84
<i>Figure 4.6 - G16 Line Participation Factors for Studies 1 - 3</i>	85
<i>Figure 4.7 - G8 Line Participation Factors for Studies 1 -3</i>	86
<i>Figure 4.8 - G1 Line Participation Factors for Studies 1, 4 -5</i>	87
<i>Figure 4.9 - G16 Line Participation Factors for Studies 1, 4 -5</i>	88
<i>Figure 4.10 - G8 Line Participation Factors for Studies 1, 4 -5</i>	89
<i>FIGURE A.1 MODIFIED IEEE 14 BUS SYSTEM</i>	<i>Appendix A</i>

LIST OF TABLES

TABLE A.1 - IEEE 14 BUS SYSTEM, BUS DATA

TABLE A.2 - IEEE 14 BUS SYSTEM, LINE DATA

TABLE B.1 - LOAD FLOW INPUT DATA AND STUDY RESULTS, CASE STUDY 1, BASE CASE

TABLE B.2 - LOAD FLOW INPUT DATA AND STUDY RESULTS, CASE STUDY 2, GENERATION SETTINGS AND BUS LOADING TWICE TO THAT OF THE BASE CASE

TABLE B.3 - LOAD FLOW INPUT DATA AND STUDY RESULTS, CASE STUDY 3, GENERATION SETTINGS AND BUS LOADING THREE TIMES TO THAT OF THE BASE CASE

TABLE B.4 - LOAD FLOW INPUT DATA AND STUDY RESULTS, CASE STUDY 4, NON SWING BUS GENERATION SETTINGS SAME AS BASE CASE, BUS LOADING TWICE TO THAT OF THE BASE CASE

TABLE B.5 - LOAD FLOW INPUT DATA AND STUDY RESULTS, CASE STUDY 5, NON SWING BUS GENERATION SETTINGS SAME AS BASE CASE, BUS LOADING THREE TIMES TO THAT OF THE BASE CASE

TABLE C.1-A - CASE STUDY 1, LINE PARTICIPATION FACTORS CALCULATED USING FORWARD FLOW RESULTS FROM LOAD STUDY

TABLE C.1-B - CASE STUDY 1, GENERATION CONTRIBUTION TO LINE FLOWS, LINE PARTICIPATION FACTORS CALCULATED USING FORWARD FLOW RESULTS FROM LOAD STUDY

TABLE C.1-C - CASE STUDY 1, GENERATION CONTRIBUTION TO BUS LOADS, CONTRIBUTIONS CALCULATED FROM GENERATORS COMPONENT OF LINE FLOWS, LINE PARTICIPATION FACTORS CALCULATED USING FORWARD FLOW

TABLE C.2-A - CASE STUDY 2, LINE PARTICIPATION FACTORS CALCULATED USING FORWARD FLOW RESULTS FROM LOAD STUDY

TABLE C.2-B - CASE STUDY 2, GENERATION CONTRIBUTION TO LINE FLOWS, LINE PARTICIPATION FACTORS CALCULATED USING FORWARD FLOW RESULTS FROM LOAD STUDY

- TABLE C.2-C - CASE STUDY 2, GENERATION CONTRIBUTION TO BUS LOADS, CONTRIBUTIONS CALCULATED FROM GENERATORS COMPONENT OF LINE FLOWS, LINE PARTICIPATION FACTORS CALCULATED USING FORWARD FLOW*
- TABLE C.3-A - CASE STUDY 3, LINE PARTICIPATION FACTORS CALCULATED USING FORWARD FLOW RESULTS FROM LOAD STUDY*
- TABLE C.3-B - CASE STUDY 3, GENERATION CONTRIBUTION TO LINE FLOWS, LINE PARTICIPATION FACTORS CALCULATED USING FORWARD FLOW RESULTS FROM LOAD STUDY*
- TABLE C.3-C - CASE STUDY 3, GENERATION CONTRIBUTION TO BUS LOADS, CONTRIBUTIONS CALCULATED FROM GENERATORS COMPONENT OF LINE FLOWS, LINE PARTICIPATION FACTORS CALCULATED USING FORWARD FLOW*
- TABLE C.4-A - CASE STUDY 4, LINE PARTICIPATION FACTORS CALCULATED USING FORWARD FLOW RESULTS FROM LOAD STUDY*
- TABLE C.4-B - CASE STUDY 4, GENERATION CONTRIBUTION TO LINE FLOWS, LINE PARTICIPATION FACTORS CALCULATED USING FORWARD FLOW RESULTS FROM LOAD STUDY*
- TABLE C.4-C - CASE STUDY 4, GENERATION CONTRIBUTION TO BUS LOADS, CONTRIBUTIONS CALCULATED FROM GENERATORS COMPONENT OF LINE FLOWS, LINE PARTICIPATION FACTORS CALCULATED USING FORWARD FLOW*
- TABLE C.5-A - CASE STUDY 5, LINE PARTICIPATION FACTORS CALCULATED USING FORWARD FLOW RESULTS FROM LOAD STUDY*
- TABLE C.5-B - CASE STUDY 5, GENERATION CONTRIBUTION TO LINE FLOWS, LINE PARTICIPATION FACTORS CALCULATED USING FORWARD FLOW RESULTS FROM LOAD STUDY*
- TABLE C.5-C - CASE STUDY 5, GENERATION CONTRIBUTION TO BUS LOADS, CONTRIBUTIONS CALCULATED FROM GENERATORS COMPONENT OF LINE FLOWS, LINE PARTICIPATION FACTORS CALCULATED USING FORWARD FLOW*
- TABLE D.1 - EXCEL CELL FORMULAE, LINE REACTANCE VALUES*
- TABLE D.2 - EXCEL CELL FORMULAE, INVERSE ADMITTANCE VALUES FROM REACTANCE VALUE IN TABLE D.1, INVERSE CALCULATED OUTSIDE EXCEL*
- TABLE D.3 - EXCEL CELL FORMULAE, 'A' FACTORS FOR GENERATOR BUSES, ONLY BUSES 1, 8, AND 16 ARE CALCULATED*
- TABLE D.4 - EXCEL CELL FORMULAE, GENERATION CONTRIBUTION TO LINE FLOWS, EXAMPLE OF TYPICAL SHEET, USED FOR CALCULATING SECTION B, OF TABLES C.1- C.5*
- TABLE D.5 - EXCEL CELL FORMULAE, GENERATION CONTRIBUTION TO LOADS, EXAMPLE OF TYPICAL SHEET, USED FOR CALCULATING SECTION C OF TABLES C1- C5*

LIST OF SYMBOLS

$A_{de,n}$	-	Shift factor relating the change in flow on line D-E, for a change in power output of generator N
$\angle\theta$	-	The angle associated with the complex quantity
B	-	The imaginary component of admittance, susceptance
CAP_L	-	The transmission capacity of transmission line L
$C_{cl,y}$	-	The capacity cost of transmission line L, in year Y, \$/MW
C_{dem}	-	A factor reflecting the power flow through transmission line joining busses D and E resulting from the power injected at bus N
$C_{e,l,y}$	-	The cost of existing transmission line, L, in year Y, \$
C_{ex}	-	Cost of the existing transmission system, \$
$C_{ex,y}$	-	Cost of the existing transmission system, in year Y, \$/year
$C_{r,l,y}$	-	The cost of reinforcements on line L, in year Y, \$
C_{rn}	-	Cost of reinforcements to the transmission system, \$
$C_{rn,y}$	-	Cost of reinforcements to the transmission system in year Y, \$/year
$C_{tl,y}$	-	The total cost of transmission line L, in year Y, \$
C_{tr}	-	Total cost of transmission system includes existing infrastructure and reinforcements, \$
$C_{tr,y}$	-	Total cost of transmission system includes existing infrastructure and reinforcements in year Y, \$/year

$D_{de,n}$	-	A factor reflecting the power flow through transmission line joining busses D and E resulting from the power removed at bus N, participation factor, dimensionless
E_n	-	The voltage at bus n, it is a complex quantity, $ E_n \angle \theta$
G	-	Conductance, and is the real component of admittance. 1/R, Siemens
G_b	-	Generation at bus B, MW
IPC_r	-	Incremental production costs, reference case, \$
IPC_t	-	Incremental production costs, total costs, \$
IPC_y	-	Incremental production costs in year Y, \$/year
IRC_r	-	Incremental reinforcement costs, reference costs, \$
IRC_t	-	Incremental reinforcement costs, total costs, \$
IRC_y	-	Incremental reinforcement costs, year Y, \$/year
IP_{cx}	-	Incremental power contribution made by customer X in year Y, MW
IP_{mt}	-	Total change in power on the system over the study period, MW
I_n	-	The value of current entering bus n, it is a complex quantity, $ I_n \angle \theta$
MW-Mile	-	The product of power flow in Megawatts and transmission line distance in miles, MW-Mile
MC_i	-	Optimal cost of power at the injection bus
MC_r	-	Optimal cost of power at the receiving bus
$PB_{i,r}$	-	Power balance between the power injected at bus I and removed from bus r, by customer X, MW
P_{de}	-	Real power flow on the transmission line joining bus D to bus E, MW
P_{den}	-	Real power flow on the transmission line joining bus D to bus E, resulting from the power injected or removed at bus N, MW

P_{wh}	-	The power flow on the interchange lines of the wheeling system, MW
P_n	-	Real power at bus N, MW
P_x	-	Customer X's peak power at the time of system peak, MW
P_{Lj}	-	The change in the power flow on line L resulting from the transaction with user X, MW
P_{psh}	-	The annual peak power on the transmission system, MW
P_{PLj}	-	Customer X's power flow through transmission line L, at the time of peak power flow, on the same transmission line, MW
PR_{LjY}	-	The price user X pays for wheeling on line L in year Y, \$
PR_{shY}	-	The total price user X pays for the use of the physical transmission system in year Y, \$
Q_n	-	Reactive power at bus N, Mvars
R	-	Resistance, Ohms
S_n	-	apparent power at bus N, a complex quantity, $P_n + jQ_n$, MVA
X_{le}	-	Imaginary component of impedance, inductive reactance, Ohms
Y_{bus}	-	An admittance matrix constructed from transmission line admittances, based on KCL
Y_{loop}	-	An admittance matrix constructed from transmission line admittances, based on KVL
Y_{nm}	-	The admittance of transmission line joining busses N and M, it is a complex quantity.
Y_{nmc}	-	The admittance value associated with the susceptance of the lines shunt capacitance, Siemens
Z_{nm}	-	The impedance of the transmission line joining busses N and M, a complex quantity

LIST OF ABBREVIATIONS

EPA	-	Energy Policy Act
FERC	-	Federal Energy Regulatory Commission
FPA	-	Federal Policy Act
IPP	-	Independent Power Producer
ISO	-	Independent System Operator
KCL	-	Kirchhoff's current law
KVL	-	Kirchhoff's voltage law
LRIC	-	Long Run Incremental Cost
NOPR	-	Notice of Proposed Rule Making
OASIS	-	Open Access Same Time Information System
OPF	-	Optimal power flow
PAM	-	Power Allocation Method
PURPA	-	Public Utilities Regulatory Policy Act
RTG	-	Regional Transmission Group
SRIC	-	Short Run Incremental Cost
SRMC	-	Short Run Marginal Cost

CHAPTER 1

ELECTRIC UTILITY REGULATORY ISSUES

1.0 INTRODUCTION

Competition in the electrical utility industry is quickly becoming common place world wide. From its origins in Chile in the late 1970's and The United Kingdom in the early 1980's, to its present implementation in North America, regulatory bodies in Canada and the United States are presently revisiting the concept of a vertically integrated electric utility industry and its suitability for providing electrical energy services to customers. The attempts at policy reshaping are being initiated to determine if greater economic efficiencies, customer savings and accountability can be achieved at this point in the evolution of this 225 billion dollar a year North American business. Conventional wisdom dictates that these objectives can be achieved.

At present, electric utilities receive a monopoly franchise for the generation, transmission and distribution of electricity, with a guaranteed rate of return to the investors, in exchange for a commitment or "obligation to serve" the customers reliably within its service

territory, at regulated rates. The opinion of many is that separate generating, transmitting and distributing sectors of the industry can exist independently to foster wholesale and retail competition within the generation and sales sectors of the industry. Simply put, what is needed is a functional and financial unbundling of the present systems and services.

Under an unbundled structure the transmission and distribution infrastructure will exist, to provide the physical assets required for the desired competition to take place. The introduction of fundamental market place concepts will require that the energy generating companies be able to reach the customers through the transmission and distribution links, in a non discriminating, open access manner. This access will be achieved through the use of some form of tariff. This tariff will be required to permit the recovery of the already expended capital investments in the transmission system while at the same time send the proper economic signals to the participants in order to obtain the required investments for future expansion.

The objective of the research presented in this thesis is to deal mainly with this subject of wheeling cost allocation. It discusses the different mechanisms available for charging for the use of transmission facilities by third parties, and presents a mathematical derivation, based on the inverse Jacobian matrix present in a de-coupled load flow study, to estimate the use of a transmission facility by a generator. The derivation outlined is applied to a number of load flow solutions in an effort to calculate the contribution of each generator's output to the total flow in each transmission line of the system. In addition, this thesis discusses the more probable structure of the industry in the future and the new role of its

participants in an effort to illustrate the requirement for the flow based types of compensation schemes.

1.1 REGULATORY HISTORY

The electric utility industry has historically been structured as a regulated monopoly system. The structural center of this system has been the distribution level franchise which was provided an exclusive service territory, in which the companies were given the right and obligation to service all retail customers. Each company's need to ensure an adequate supply of energy to meet its obligations extended the exclusivity to the generation supplies and the transmission systems needed for the delivery of this energy. The monopoly franchising structure was enacted so as to enable highly capital intensive utilities the opportunity to raise the financing needed for projects and to spread out the recovery of these costs over a 30 or 40 year period with the guarantee of a stable customer base.

In the United States this monopoly structure remained until the late 1970's. At that time the Public Utilities Regulatory Policy Act (PURPA, 1978) of the U.S. increased the U.S. federal government's involvement in the electrical industry in an effort to encourage the generation of electricity from waste fuels, waste steam and renewable sources, and to promote the utilization of steam from generation for other purposes. Energy produced by such means was required to be purchased by public utilities at avoided costs, in an effort to limit the country's reliance on foreign oil. PURPA (1978) was drafted after the oil crisis of the mid 1970's. As a result of the opportunities provided by PURPA, and in combination with advancements in natural gas fueled combined cycle generation technology, industries in some states determined that it was beneficial to by-pass electric utilities and generate their

own electricity. (At this time industries were witnessing substantial increases in industrial electrical rates. From 1970 to 1985 industrial prices increased by 86%, and residential prices increased by 25%, after adjusting for inflation [1]).

Based partly on the success of PURPA and the influence of the Independent Power Producers (IPPS) which flourished as a result of PURPA, revisions to the Energy Policy Act (EPA) of the United States (Oct, 24, 1992) were undertaken to strongly encourage an increase in the competition for the wholesale distribution of electricity. This increase in competition was achieved by increasing the authority of the Federal Energy Regulatory Commission (FERC). This increase in authority permitted FERC to order transmitting utilities to provide wholesale transmission services to agencies generating electricity for sale or resale [2]. At that point in time many very large electricity consumers, hence employers, were threatening to move out of their present states, and into states which could supply lower cost energy. These employers demanded access to lower cost supplies from other states through their elected state representatives. (Average utility rates range from 3 to 5 cents per kWh in the northwest to 9 to 11 cents per kWh in California [1]). Some of the cost differences which existed from state to state were the result of cost based compensation schemes which enticed certain utilities to over invest in generating assets, particularly nuclear sources. Poor business philosophies developed from the credo "the meters will go around" and other personal opportunities that present themselves in a non-competitive culture, also attributed to price variance. The need to modify the powers of FERC was necessitated by the Public Utilities Holding Company Act (PUHCA) of 1935.

The PUHCA limited the ability of a company to acquire geographically distant utility assets through holding companies, thereby limiting a holding company's influence to a single state. The holding act was necessary because in 1932 about one half of the investor owned utility market was controlled by three holding companies.

As a result of these regional price differences FERC issued three Notices Of Proposed Rule making (NOPR), two on March 29, 1995 and another on December 13, 1995. The Commission then held extensive hearings into the transmission of electric energy under its authority to regulate industry wide interstate commerce and its authority to remedy undue discrimination as granted by section 205 and 206 of the Federal Power Act (FPA), [1]. As a result of these hearings FERC has published two final rulings contemporaneously on April 24, 1996, that have fundamentally changed the electric utility industry in the United States and, without direct authority, in Canada as well. These final rulings are FERC order number 888 [1], which contains both the final rule on open access and the final rule on stranded cost and FERC 889 [3], which contains the final rule on an open access same-time information system, (OASIS). These 3 interrelated final rulings are designed to remove impediments to the wholesale trade of electricity, and to give the industry new direction and operating guidelines, in an effort to reduce customer costs. As a result of consolidating and streamlining operations, FERC estimates that the benefits from these rulings to be \$3.8 to \$5.4 billion per year in the US in cost savings. Non-quantifiable benefits that include better use of existing resources, anticipated technical and market innovations, and less geographical rate distortions are additional benefits [1].

1.2 FEDERAL ENERGY REGULATORY COMMISSION RULE 888

The Federal Energy Regulatory Commission (FERC) ruling 888 is exhaustive by way of including the arguments for and against the policy changes directed toward a re-regulated industry, and as well, the commission's decisions on each policy. Only five of the many aspects which effect re-regulation and which are most relevant to this thesis will be mentioned.

1.2.1 Open Access

The legal and policy cornerstone of these final rulings is the ability to remedy undue discrimination in access to the monopoly owned transmission systems that control whether and to whom electricity can be wheeled. The remedy is mandated open access, a prescription that involves wheeling. There are many definitions for wheeling. Simply put, wheeling is basically the transfer of electrical energy by a transmission or distribution owning utility for other buyers and sellers. In the past, if wheeling was done, it was generally done on a voluntary and goodwill basis enacted with a simple compensation scheme. The final rule now requires public utilities, which have facilities which could be used for the trade of electricity in interstate commerce, to file a single non-discriminatory open access tariff. The tariff is to offer both network load based service, and contract point-to-point service, to third party users of the system such as Independent Power Producers (IPP's), energy marketers, and competing utilities. Under this new system, a transmitting utility's native load is to be treated no differently then that of a third party generator. The commission acknowledges a lack of market power for generators by recognizing that transmission services remain a natural monopoly due to economies of scale and that undue

discriminatory and anti-competitive practices exist today in the electric industry. The commission expects that this open access rule will provide those customers who are presently captive to a single supplier, the ability to obtain less expensive energy.

1.2.2 STRANDED COSTS

There are many definitions for stranded costs as it applies to electric utilities in a re-regulated environment. Basically stranded costs are all legitimate, prudently incurred and verifiable investments made by an electric energy provider in physical assets, binding power purchase contracts, and long term fuel purchase contracts, which were entered into in order to fulfill their regulatory obligations and which would have been recoverable but for the implementation of competition, and which as a result of this regulatory change, cannot be reasonably recovered. When a utility sells its facilities, or cancels contracts, the difference between the book value and the proceeds of the sale is considered the stranded cost. The final rule provides a formula for calculating the stranded costs based on a revenues lost approach.

The commission discusses numerous scenarios that could produce stranded investments in an industry undergoing a transition from a regulated to competitive market place. Most of the commissioner's comments relate to the generation portion of the industry. The commission's conclusion on stranded costs is highlighted in the following quote from the final rule. "We reaffirm our preliminary determination that the recovery of legitimate, prudent and verifiable stranded costs should be allowed" [1]. The justification for their position on guaranteeing investments takes its lead from the US President's economic

report of February 1996. The relevant portion of interest in the economic report compares the rates of return for regulated and free market companies in good and bad economic times. The economic report makes a case for allowing utilities to recover stranded costs where these costs arise from after-the-fact changes in regulatory philosophy. The recovery of these charges may come about through the implementation of a competitive transition charge to all customers or through the application of exit fees to specific customers.

1.2.3 RECIPROCITY

While the Commission has no authority to order private utilities to open up their transmission lines indiscriminately to third party suppliers, the commission has instituted a provision where by any private utility which wishes to avail of the wheeling opportunities presented to them by public utilities must themselves provide public utilities with services equivalent to those which they are providing to themselves in a nondiscriminatory manner. It is this provision which ultimately effects the electric utility industry in Canada. An excerpt from the final rule states;

The posturing of Ontario hydro before the U.S. regulators pleading for open access and non-discriminatory transmission treatment -- even for extra-territorial entities, should be met with a strong reply that such provisions should also be afforded transmission dependent entities on the Canadian side of the border. Ontario Hydro's aggressive pursuit of U.S. market opportunities while the posturing of Ontario Hydro before U.S. simultaneously blocking competitors through the control of their transmission assets can not be ignored [1].

For this to occur in Canada the language, in what is expected to be chapter 12 of Canada's

Internal Trade Agreement which will deal with inter-provincial wheeling, will have to resemble the reciprocity provision of FERC 888 in the U.S.

1.2.4 FLOW BASED PRICING VERSES CONTRACT PATH PRICING

The suitability of contract path pricing and flow based pricing for transmission customers in a re-regulated industry, is discussed in final rule [1]. The commission states that they will not require flow based pricing at the time the final rule is issued because the introduction of such a requirement could delay the change towards re-regulation. The commission, however, does conclude that the long standing use of contract path pricing for determining wheeling tariffs does not adequately reflect the use of the transmission system by generating companies, and as a result does not conform to economic theory regarding generation siting and efficient use of resources. In an effort to more adequately reflect the use of capacity costs which was requested by the participants in the hearing, the commission endorses the development of flow based pricing methodologies so as to eventually implement proven methodologies. The commission final report states "...We wish to emphasize ... we are not endorsing the traditional contract path approach as the only available approach...but need to see better developed approaches from the industry before we can consider generic adoption of alternative pricing" [1].

The commission recognizes the need for flow based pricing schemes and that further development of these schemes is needed before their implementation.

1.2.5 INDEPENDENT SYSTEM OPERATORS

Independent System Operators (ISO) are fully regulated, independent corporate entities,

which are formed to manage the interconnected transmission systems of numerous utilities for the benefit of all potential transmission users and not only to the benefit of the owners of the physical plant. In addition to the day-to-day operation of such things as real and reactive load balancing, restoration, back-up / spinning reserve, and energy dispatch, the function of the ISO is to notify system users of things such as available capacity, required maintenance, security constraints, etc. The commission concludes that functional unbundling of wholesale services is necessary to implement nondiscriminatory open transmission access and that corporate unbundling should not be required, and hence are not mandating generation divestiture by the transmitting utilities. In undertaking this move to functional unbundling, the commission recognizes that an ISO could play an important role in the competitive bulk power markets. The commission has issued codes of conduct by which the operational unbundling of utilities, through ISOs, should operate to provide wholesale buyers and sellers access to electric power, if an ISO should choose to be constructed. The objective is to regulate the monopolistic portion of the industry while permitting competition to take place in the other sectors. The basic underlying principle of ISO operation is the complete removal of the ISOs daily operation from the utility companies from which the ISO was constructed. Control room personnel and management are to have no financial interests in, or are not to be influenced by, any of the utilities for which the transmission infrastructure is being operated. The ISOs are to have business strategies and goals which address the needs for nondiscriminatory electricity transport.

FERC'S recommendations and determinations on these and other important issues will be the blue prints by which industry management, and its engineers, are required to function.

1.3 FUTURE STRUCTURE

Based on the rulings of FERC 888 and the recommendations contained within, it is inevitable that the structure of the industry is going to have to change to accommodate the ruling. In some US states it has already changed. The greatest influence of the FERC ruling with respect to re-structuring, comes from its requirement to force utilities that have generation, transmission and distribution facilities to functionally unbundle the generation assets from those of the transmission and distribution infrastructure in order to provide electrical customers with nondiscriminatory access to electrical generation. The Electrical Power Act (EPA) makes no distinction between the transmission and the distribution facilities in terms of their wheeling potential [2]).

1.3.1 GENERATION SECTOR

The generation sector will be the first sector in the industry to fully feel the effect of market place forces. The traditional use of cost based revenues will be abandoned for revenues generated from auctions and spot pricing. This change will create enormous stranded costs. This fundamental change in the way revenues are generated will force the generating utilities to entertain innovative mechanisms for marketing their product and for limiting financial risks. Market strategies, developed from the use of financial instruments common in the equity and bond markets, such as options, forward contracts, futures and interruptible services (from both the supply and demand sides), will be available to provide economic

incentives to the market participants who can strategically use their flexibility in generation and consumption patterns to provide immediate economic gains and hedges against market risks. References [4-8] deal with issues related to market clearing prices, bidding and contract concepts.

It is expected that the majority of contracts undertaken in the proposed structure will be multilateral, although bilateral contracts will exist as well. The exchange of these contracts is expected to be facilitated through the construction of power exchanges, (similar to a commodities exchange), in association with the ISOs. The bids are expected to include such things as amount of energy, peak demand, duration, delivery and receipt points, firmness, price, etc. Generators and customers will provide closed bids electronically, reference [3], and the lowest priced generators will be matched to the highest paying customers subject to system constraints.

1.3.2 TRANSMISSION SECTOR

Based on the Federal Energy Regulatory Commission's requirements and on the comments of industry participants in the de-regulation hearing, it appears as though the functional unbundling requested to manage the transmission assets, will come about through the creation of Independent System Operators (ISOs). To function properly ISOs will require the operational unbundling of existing utilities. The likelihood of the existence of ISOs was anticipated by the commissioners who as a result, have proposed guide lines for their creation. ISOs are an advancement in the concept of the power pools, and Regional Transmission Groups (RTGs), which are present in different parts of North America.

Transmission line owning utilities will hand over the operation of their transmitting assets to the independent system operator.

In a transmission industry structured around ISOs and competitive bidding processes, the ISOs, in close association with the power exchange, will permit the execution of generation-customer contracts, based on line availability, frequency control, voltage stability, and other security constraints. From an engineering perspective this could be seen as the new form of economic dispatch. In order to ensure system security, in a structure such as this, the ISO will have to manage the production resources required to maintain the reactive and real power needed by the system itself as result of the underlying physics associated with supporting an electricity transportation system. This system support will be achieved by guaranteeing black start capacity, quick start and spinning reserves and by calling for amounts of reactive power from locationally selective suppliers. These system requirements will be called for by the ISO for its own use, and will most likely be achieved through the use of auctions. Having first satisfied these requirements, the ISO will then will have to direct and divert real energy throughout the system, without prejudice, to accommodate the sell and buy matches. It is from this random and selective wheeling of real energy over the transmission lines that transmission owners will seek compensation for the use of their physical assets. In a phrase, "the flow of dollars will have to follow the flow of electrons". It is the need, the ways, and the means for calculating this compensation to the transmission owning utilities for the use of their lines which this thesis is interested in. The added production expenses associated with line losses and reactive power requirements will be

touched on.

1.3.3 DISTRIBUTION SECTOR

It is inevitable that retail competition will follow wholesale competition. Retail competition has already been implemented as test studies in some US states, and full customer choice will be implemented in a number of US states in January 1998. An industry where a residential customer negotiates directly for his/her power needs, or does so through a broker, will initiate changes to the distribution portion of the industry. Distribution companies will still act as servicing companies and will be expected to provide and maintain the physical infrastructure for delivering energy. They will be compensated for this effort through regulators based on investment costs and associated expenses. However, distribution companies will as well resemble power marketers with corporate objectives different from that of the regulated portion of the distribution industry. One of the major differences between the old form of the distribution industry and the new form will be the fact that energy consumers will now be looked upon as "customers" as opposed to rate payers. To attract and maintain these customers different customer service and marketing strategies will be attempted to manage this relationship. Marketers from the distribution utilities will enhance their product with promotions such as appliances, and cellular phones, or will bundle their energy sale with remote control of heaters, real time billing to provide off peak rates, and other services, as provided through an alliance with communications companies. The sale of 'green power', generated from environmentally friendly sources will be promoted. Electric bills which highlight the cost of the supply from the generator, and

the cost of transportation from the transmission and distribution companies are expected to be common place.

This dual role of the distribution companies will require the separation of business activities and financial records.

The remaining chapters of this thesis consist of re-regulation issues associated with the costs of the transmission infrastructure.

Chapter two deals with the wheeling cost allocation schemes that are under consideration for allocating the costs of the physical transmission plant between users. This chapter presents a critical discussion of the literature dealing with this topic.

Chapter three contains the generalized participation factors. The generation participation factor is derived.

In chapter four, the modified IEEE 14 bus sample power system has been successfully simulated in order to determine the suitability of the proposed generalized participation factors.

The conclusions, summary and suggestions for future works are outlined in chapter 5.

CHAPTER 2

WHEELING COST ALLOCATION SCHEMES AND PRICING

2.0 INTRODUCTION

The present and long established means for calculating compensation for wheeling transactions has been the contract path method [1]. This method is often referred to as the fictitious contract path. In the anticipation of the more numerous and complex wheeling transactions that will result from a competitive generation environment, utility management are not expected to be satisfied with this approach as a method for calculating the rental costs for energy space on the transmission lines for which they are financially responsible. As pointed out earlier, the Federal Energy Regulatory Commission (FERC) has recognized this shortcoming and has encouraged the development of other costing schemes to more accurately reflect the use of a transmission system. The capital cost of the physical infrastructure making up the transmission system, and its associated protection and control equipment, are the greatest component of the total transmission costs. These costs, once undertaken, are independent of network operation. This chapter outlines some of the methods under consideration for allocating these costs between system users, and evaluates their positive points as well as shortcomings by way of a critical review of the present cost

and pricing literature.

All the methodologies discussed will be those methods which are appropriate tools for analyzing the costs associated with firm transactions. Firm transactions are that class of transactions for which the wheeling utility commits to having sufficient reserved capacity available to transmit the peak power agreed upon, either between the designated sending and receiving busses, or on the network as a whole, which ever the contract specifies. This class of power is distinguished from non-firm contracts which are more optimally driven. This concept is fundamentally similar to the distinction between firm and non firm power sales.

The costs to be analyzed are those costs associated with the construction and operation of the transmission network. To create an indication of what is being discussed, the literature generally separates the cost of electricity transmission into the following three groups:

- 1) Existing system costs: The cost of the existing transmission system is the cost associated with the investment made in building and the expenses incurred in maintaining the present transmission system. These costs have been incurred, and the question becomes how to allocate these costs among transmission users [9]. Shirmohammadi in reference [10], refers to this group of expenses as embedded costs, presumably because they are prevalent in embedded cost analysis. These are listed as follows:
 - return on the transmission rate base; money to pay for the long term debt, borrowed to install the plant,
 - depreciation of transmission facilities, return of investment,
 - operation and maintenance; hardware replacements, inspections, repairs etc.,
 - taxes; property, federal ,provincial, differed,
 - administrative and general expenses; engineering, transportation, environmental, etc.

The detailed list is available in reference [11]. Traditionally, utilities rolled all their generation, transmission, and distribution costs into one financial report. These past reports will now require dissection to determine appropriate transmission costs, in

order to prevent cross subsidization between different sectors of the company, and to calculate any stranded investments in a particular sector, and as well, to make any economic decisions.

2) System operating costs: The operating costs of a transmission transaction are the production (primarily fuel) costs that a utility incurs in order to accommodate the transaction [9]. They result from changes in;

- cost of line losses, $I^2 R$,
- cost of rescheduling caused by line loading constraints and bus voltage limits,
- cost of re-dispatch associated with start up time and spinning reserve, unit commitment,
- additional operation and maintenance.

Happ in reference [2] refers to these functions as ancillary services and adds,

- frequency regulation,
- back up support to the source of the wheel.

To the above list Wollenberg in [11] refers to these types of costs as "marginal costs", presumably because these types of expenses are analyzed in marginal cost analysis. Happ in [11] refers to these costs as both "production" and "operating costs".

3) Reinforcement costs: Reinforcement costs are those transmission infrastructure costs incurred to increase the capacity of the system to accommodate the wheeling transaction. These as well can be credits for delaying or avoiding reinforcements [9,11]. The needed reinforcements, and associated capital costs, are determined through the application of traditional least cost transmission expansion methodologies based on expected load growth and geographical position. Generation costs to provide Var support are not included here.

The costs listed above are quoted on an annual basis in this thesis to maintain simplicity in the analogies. However, in reality for a transmission utility, the original up front costs of construction have to be translated into an annual revenue requirement to determine the yearly income required to compensate the creditors for the money borrowed over the life of the project. This calculation of annual revenues involves accounting considerations that

spread the cost of construction out over a 30 or 40 year period, calculate interest on the money borrowed, depreciate the value of the installed plant over its life, account for inflation, as well as other financial issues. This is done to establish the connection between the present worth of the installed plant, and the price the users of the system must pay in every year of the systems life, in order to make the investment profitable.

2.1 DISCUSSION OF TERMINOLOGY

The treatment and calculations, as applied to costs and pricing in the literature, can be confusing if critical attention is not given to the headings, and subheadings, under which the costs, are discussed. As written by Shirmohammadi in [12], "For a technical review of cost based pricing , the distinction between transmission prices and costs becomes very difficult and confusing. This is particularly true when we discuss the incremental transmission pricing methodologies and may explain much of the confusion in the existing literature on costs and prices". If a reader is keenly aware of the context and headings in which costs are discussed the reader will find that, with very few exceptions, each paper produces the same information, and the same results, the difference is mainly in the approach to the presentations taken by the authors, and the use of words such as "costs" and "methodology".

Shirmohammadi and Happ [11,12] both address the problem of terminology by imposing a distinction between costs and price. For these two authors "costs" are considered as the components of the system, which when put together, will create a "price", which the wheeling utility will charge. These two authors structure their papers by defining prices and then break these prices down into sub components called costs. Other authors introduce their discussion by outlining costs and then build these costs into a price, without making

the distinction between costs and price[13]. As well, some authors use the same or similar word to describe two different concepts. In [9], under the heading of 'existing system costs', Shirmohammadi states that "... this method is known as the "postage stamp" or the "rolled-in" method". Depending on the definition the reader could think that these two terms are one in the same. However in [12] this same author classifies "postage stamp methodology" as a sub classification of the "rolled-in Transmission paradigm". This can be confusing. On the same topic in reference [11] the author uses a classification called "Rolled-in-embedded Method" under which he says " the rolled-in method assumes that the entire transmission system is used in wheeling irrespective of the actual transmission facilities that carry the wheel... Which is the reason that this method is also called the postage stamp method. The embedded capital costs correspondingly reflect the entire system". This is a little different from those in reference [12]. In reference [14] the author, under the heading of "embedded methods", states "...Allocation methodologies differ on their definition and measure of this "extent of use". They can be classified as load flow based methods and rolled-in methods the main short comings of the latter methods (such as postage stamp and contract path)...". What the author is saying here is that the contract path method is a rolled-in method, as is the postage stamp method, however contract path pricing is not, according to the definition quoted from reference[11]. The reason is that the contract path does not assume the use of the entire system in the transaction, however it could be if the definition in reference [12] is followed. This analysis may seem trivial, however it can be very confusing, as the differences are subtle. The best approach when reading the literature is to look past the definitions and at the underlying philosophy of the discussion.

There are other examples of these sorts of loose definitions in the literature. To establish a standard by which to explain the different cost methodologies, and to avoid confusion in this thesis, this author will use a distinction which is used by Shirmohammadi and Happ in most of their publications. Prices and price methodologies will be calculated based on the costs or the cost methodologies (allocators) used. The cost methodologies will be allocators for dividing up the cost of the system between users. Price methodologies will be the way the costs are combined and structured to establish price.

2.2 PREMISE

To evaluate the different cost and pricing methodologies a standard or criteria has to be established by which to make judgments. Based on the final ruling FERC 888 [1], the following two issues will be the criteria for making evaluations.

2.2.1 INDUSTRY STRUCTURE

In FERC 888 [1] the commission indicates that there will be no competition in the transmission component of the industry. Their argument is that sufficient economies of scale are present in the transmission system, from which natural monopolies develop. Statements similar to the previous are found in other papers [15,16]. Because there will be no competition, for now, market based, or value based rates will not be considered. Prices based on supply and demand for transmission services where transmission customers will pay based on what they feel it is worth to them, will not be discussed, simply because the transmission customer will have no other source from which to shop for services. To that end, the long established custom of cost based pricing will continue in this sector of the industry in the near future.

2.2.2 STRANDED COSTS

In final ruling 888 [1], FERC has stated that all verifiable costs will be recovered. With this concept in mind it will be required that the costs of the transmission network be recovered from the users of the network to prevent any cross subsidization from other parts of the utility industry or from outside sources, and to ensure that the transmission network receives sufficient revenue to pay for the plant installed, the maintenance associated with it, and return on investment.

2.3 PRICING SCHEMES

As pointed out earlier, the groupings, structure, and terminology presented in the papers is not consistent. However, pricing methodologies, can be broken down into three major groups. Hupp in reference [11] breaks them down in the following two groups:

- 1) embedded cost of wheeling methods,
- 2) long run incremental cost of wheeling methods.

In reference [17] he adds the following to the above list:

- 3) short run marginal cost methods.

Shirmohammadi, in reference [12], breaks costs down into two major groups, while covering the same material. His groupings are:

- 1) rolled-in transmission pricing paradigm,
- 2) incremental transmission pricing paradigm.

In an earlier work [10], which is a fundamental paper on wheeling, Shirmohammadi lists three pricing schemes as:

- 1) embedded cost pricing,
- 2) marginal cost pricing,
- 3) value based pricing.

One needs to note, however, that the structure and titles are not as important as are the underlying concepts.

2.3.1 EMBEDDED PRICING

With this form of pricing scheme, as outlined in method number 1 of references [10-12, 17], the costs of reinforcements to the transmission system, if required, are added to the costs of the existing infrastructure when costing calculations are performed. If the costs of reinforcements are added to the total costs of the existing infrastructure to create a new total cost, then the possibility exists for identifying the cost allocator as a rolled-in method. If the cost of reinforcements are added to the costs of the specific facility to which the reinforcements are made, then the term embedded cost is probably more appropriate. This total cost, either calculated on an entire system bases or on a facility-by-facility basis, is then divided between the users of the system based on some allocator to apportion the existing costs and reinforcement costs between the transmission users. There are numerous allocators listed in the literature, Happ in [11, 17], lists some of these as:

- 1) rolled-in-embedded,
- 2) contract path,
- 3) boundary flow (line by line),
- 4) boundary flow (net interchange),
- 5) line -by -line negative change,
- 6) line -by-line magnitude addition,
- 7) line- by -line only positive change.

Accordingly, to Shirmohammadi in reference [13] they are:

- 1) postage stamp methodology,

- 2) contract path methodology,
- 3) distance based MW- Mile methodology,
- 4) Power flow based MW-Mile methodology.

Others use some of these methodologies via different names [14]. Note that while some of these allocators use the term "transmission line" only, the understanding is that the same methodologies apply to other transmission resources such as transformers, reactors, relays, and other substation equipment.

2.3.1.1 Postage Stamp Allocator as applied to embedded pricing

Through the use of this allocator the yearly existing system costs $C_{e,x,y}$, are added to the yearly reinforcement costs for the entire system $C_{r,x,y}$, to create a total system cost, $C_{t,x,y}$, as:

$$C_{t,x,y} = C_{e,x,y} + C_{r,x,y} \quad (2.1)$$

The total system cost $C_{t,x,y}$, is then divided between the system users, based on a users load at the time of system peak, to determine the annual price which the user will pay to the wheeling utility:

$$PR_{x,y} = C_{t,x,y} * (P_x / P_{p,y}) \quad (2.2)$$

Where, $PR_{x,y}$ is the total price user x pays for system use per year, in year y,
 P_x is user x" power at the time of system peak, and
 $P_{p,y}$ is the annual peak power on the system.

It is to be indicated that no load flow or system studies are conducted with this allocator.

2.3.1.2 Contract Path Allocator as applied to embedded pricing

The contract path allocator, also called the point-to-point method or sometimes the red line method, assumes that the electricity wheeled is confined to a particular path on the transmission system and that other parts of the transmission system do not transmit any of the energy. All charges for wheeling based on this method are based on the cost of the

capacity of the lines that make up the link between the sending and receiving busses. Reinforcement costs, if they exist, are added to the existing plant costs of the lines in question if the reinforcements are on the path specified. No load flow or system studies are required.

On a per line basis the total yearly cost of a line is given as:

$$C_{u,y} = C_{eL,y} + C_{rL,y} \quad (2.3)$$

where, $C_{uL,y}$ is the total cost of transmission line L , in year y ,
 $C_{eL,y}$ is the cost of existing plant on line L , in year y and,
 $C_{rL,y}$ is the cost of reinforcements on line L , in year y .

The yearly per capacity cost of a line, in \$ per MW is given as:

$$C_{cL,y} = C_{uL,y} / CAP_L \quad \$/MW \quad (2.4)$$

where, CAP_L is the capacity of line L .

The yearly price of wheeling on line L for user x would be

$$PR_{xL,y} = C_{cL,y} * P_{p,x} \quad (2.5)$$

where, $PR_{xL,y}$ is the price user x pays the wheeling utility for the use of line L , in year y and,
 $P_{p,x}$ is user x 's peak power on line L .

The total price for wheeling will be the price per line summed over all the lines in the contract path and is given as:

$$PR_{x,y} = \sum_L PR_{xL,y} \quad (2.6)$$

where, L are the lines in the path.

2.3.1.3 Boundary Flow Allocator as applied to embedded pricing

Boundary flow allocation of costs are very similar to those of the postage stamp allocation above, in that the costs of any reinforcements required to accommodate the transaction are lumped in with the costs of the existing system without consideration for where the

reinforcements are placed and for whom they most benefit. The net effect to a system from a wheeling transaction passing through the system is calculated by performing load flow studies with and without the wheeling transaction to determine the quantity of transacted power passing through the system. Modifying reference [11], the yearly price paid to the wheeling company is calculated based on two approaches:

$$\text{intertie-by-intertie: } PR_{w,y} = C_{w,y} * (1/2 \sum_i |\Delta P_{i,w}| / P_{w,y}) \quad (2.7)$$

Where, $P_{w,y}$ is the power on the interchange lines of the wheeling system.

$$\text{net interchange: } PR_{w,y} = C_{w,y} * (1/2 \sum_k |\Delta \text{net interchange}_k| / P_{w,y}) \quad (2.8)$$

Where, net interchange is power flow between the wheeling utility and a neighboring utility K.

It is to be noted that equations (2.7) and (2.8) are not the same because of loop flows which can go out through one neighboring utility and come back into the wheeling utility through another neighboring utility.

In reference [13], the author approaches the boundary flow a little differently by considering only the change in power flowing out of the wheeler's system. The author calls it the "power allocation method", (PAM), and still bases the wheeling price on the total system cost. The author does not call it an embedded method, he simply lists PAM as a tool for application and expresses the total yearly price a wheeling customer pays for the use of the physical system assets is given as:

$$PR_{w,y} = C_{w,y} * [(\sum_k (\text{flow}_{\text{out}, k} - \text{flow}_{\text{in}, k})) / \text{magnitude of transaction}] \quad (2.9)$$

2.3.1.4 Megawatt-Mile Allocator as it applies to embedded pricing

The Megawatt-Mile allocator is the most popular and most discussed cost based allocator in the literature. This is the principal flow based allocator referenced by FERC in ruling 888 [1]. A number of authors express similar ideas on how to implement a flow based allocator and on what a flow based allocator should be based. For the purposes of this thesis some of the more relevant works will be individually discussed.

Reference [10] is one of the earliest papers on flow based allocators and is widely referenced by other authors. In this paper, Shirmohammadi describes a flow based allocator which distributes costs between users based on their use of the total system cost, and system capacity. The author begins by first determining the cost of per unit capacity per mile for each line, a term which he calls W_l . His per unit capacity per length cost W_l , is not a multiplier based on the actual expenses incurred to build a particular line, rather it is a more general estimate based on construction practice. This allocator determines the cost per megawatt-mile capacity of a line based mainly on the voltage class of the line, but as well includes such things as the conductor type used in the lines construction, and probably, although he does not specify it, tower design. Once determined, this cost per unit capacity-length for each line, W_l , is then multiplied by the magnitude of the power being wheeled across line l and then again by the line length of line l to establish a dollar figure for the power transferred over the line in question. This process is repeated for all lines in the transmission system to create a summation. This process is then repeated again for all transactions in the system to create a summation of the summations. This double summation is then divided into the summation of a particular transaction to establish the total price paid to the wheeling company for that transaction. Any reinforcements required

to accommodate the wheeling transaction would be added to the total existing system costs, not on a facility-by-facility basis, but to the system as a whole. Accordingly, the expression for the price a customer pays per year for the use of the physical transmission system is given as:

$$PR_{x,y} = C_{x,y} * [\sum_l W_l * P_{x,l} * L_l] / (\sum_x \sum_l W_l * P_{x,l} * L_l) \quad (2.10)$$

where, W_l is a factor reflecting the cost of line l on a megawatt-mile bases ($\$/\text{MW}\cdot\text{M}$),
 L_l is the length of line l in miles,
 $P_{x,l}$ is the power flow over line l at the time of system peak resulting from the transaction of user x and,
 X is the set of all transactions.

The author indicates that the method for determining the flows on the lines resulting from each transaction is to be enacted by performing dc load flow analysis on each transaction without having any of the other transactions present in the system. Transaction x is the only flow on the system at the time the dc load flow is performed. This method does not account for the interactions of simultaneous power flows on the system. However the effects of simultaneous transactions can be drawn out of the author's second example in reference [10] where he employs generation shift factors.

In Shirmohammadi's second example, he complicates the analysis by suggesting wheeling transactions whereby multiple loads and multiple generations are present in a contract, and both vary between minimum and maximum values over the wheeling contract period. The author then presents the problem of how much line capacity must be reserved on each transmission line so that the wheeling company can ensure its commitment to always having adequate capacity on the system to satisfy the wheel, and then to ultimately charge the company requesting the wheel based on the capacity that the wheeling utility has to set aside. The wheeling utility cannot rent the needed line capacity to any other company

because the wheeling company has committed to having the reserves in the line. The author poses the solution to this problem of multiple sources and loads, by performing a load flow analysis on the system with only this group of transactions present. He then suggests that the wheeling company estimate, and make constant, the demands at the load buses, from company X, at the time of system peak, in order to remove one group of changing variables from the possible solution. It is then suggested that the wheeling utility adjust the amount of generation by company X, over all of its extremes (generation limits of company X) to determine the resulting maximum flows possible on each line, that can be created, depending on the method of dispatch chosen to feed the fixed loads. This method for simulating line flows over the variation in generation, is through the use of generation shift factors which permit the wheeling utility to simulate the possible scenarios of generator dispatch. The equation for determining a price to the company wishing to have power wheeled is structured the same way as before except that P_{ij} , which was constant before, is now the maximum of company X's flow over line l as detected through possible variations in dispatch.

Happ in reference [11] provides his version of a megawatt-mile methodology under the heading "line-by-line method". For this author's analysis the total system cost is the cost of the existing transmission plant plus the cost of reinforcements, same as noted in equation (2.1). However, in the case of reference [11] the costs are based on accounting practice as opposed to estimates based on construction habits. It is this difference in determining the costs of the facilities that differentiates the two methods. Happ in [11] suggests that in order to determine the amount of power which flows over a transmission line as a result of a transaction, the wheeling company should complete two load flow simulations on the

wheeling system. One study without the wheel present and one with the wheel present, to establish the difference in line flows. This method for determining line flows is different than the previous method proposed in reference [10]. Happ in reference [11] includes accounting considerations such as net plant value, depreciation, present worth analysis and annual fixed charge rates in his original equation. Accordingly a simplified expression for the yearly price which a transmission customer must pay for the use of the physical plant is written as;

$$PR_{x,y} = C_{x,y} * (\sum_l \Delta MW \text{ Miles}_{l,x} / \sum_l MW \text{ Miles}_l) \quad (2.11)$$

Where, $\Delta MW \text{ Miles}_{l,x}$ is the change megawatt flow on line l as a result of transaction x multiplied by the length of line l in miles. There are three variations, they are given as,

- 1) Where the negative $\Delta MW \text{ Mile}$ changes on lines are subtracted from the positive $\Delta MW \text{ Mile}$ changes on lines to produce a lower wheeling cost. Produce a credit if negative,
- 2) Where positive and negative line changes are first converted into magnitudes before being add, same as Shirmohammadi, and thus all wheels contribute to an increase in wheeling costs, and,
- 3) Where only positive $\Delta MW \text{ Mile}$ changes are considered, negative $\Delta MW \text{ Mile}$ changes are treated as zero, thereby removing the opportunity for a credit, while at the same time not creating a penalty.

It is suggested that $MW \text{ Miles}_l$ can be either;

- 1) 1) the total load on line l , in megawatts multiplied by the length of line l in miles. Happ does not indicate at what time the total load is to be determined, however it will be assumed to be at system peak. Shirmohammadi in reference [10] only considered line rating.
- 2) the line capacity of line l , in megawatts multiplied by the length of line l in miles, same as Shirmohammadi.

Kovacs in [13] describes three versions of a megawatt mile allocator, his last two, which come under the heading "Generalized Flow Mile Methods" are fundamentally the same as other works. He describes an allocator that divides up the systems total cost in the same way as reference [10] and as in reference [11], where the author permitted the division or derivations of costs based on some measure of system capacity. In reference [13], the author reserves the term "megawatt-mile method" for cost division based on capacity. The second method under this same "Flowmile" heading is the same as that of reference [11]. In that reference Happ divides up the costs of the system based on a ratio of total flow-distance change resulting from a transaction, to the total flow-distance on the system from all transactions, a ratio of use as opposed to a percentage of installed capacity.

Kovacs' first megawatt mile allocator, which he places under the heading " Usage Method", is in some ways similar to other methods, in reality they are all similar. However, what is unique about Kovacs' analysis is that he does his analysis on a facility-by-facility bases as opposed to a regional or system wide bases. His approach is to divide up the cost of each individual line amongst the users of that line. This division is based upon the impact that a wheeling transaction has on a particular line as determined by the change in the line flow. The total yearly price which a transmission customer must pay based on the user's percentage of flow over each line can be written as.

$$PR_{xy} = (\sum_l C_{lj} * |\Delta P_{lj}|) / (\sum_l \sum_n |\Delta P_{ln}|) \quad (2.12)$$

Where, PR_{xy} is the total price paid by user X to wheel on the system,
 C_{lj} is the total cost of line L, and
 ΔP_{lj} is change in power flow on line L resulting from the transaction with user X.

Kovacs, like Shirmohammadi, uses absolute value signs in the equation to account for changes in power flow, and does discuss the effects of not using the absolute value signs.

For Kovacs, the costs of reinforcements are attributed to the particular line which receives the reinforcements and not to the entire system. Kovacs does this analysis under the heading of “embedded cost methods”, as opposed to “rolled-in allocators”. This is a good example of highlighting some of the confusion in the literature regarding these two terms. The costs in this example are rolled-in on a line-by-line basis to those lines receiving reinforcements as opposed to being rolled into the entire system costs, which is why it is referred to as an embedded method. It is to be clarified that it is not a rolled-in method because all costs are not rolled-into one number for the entire system.

2.3.2 DISCUSSION OF THE EMBEDDED COST METHODS

2.3.2.1 Postage Stamp Method

The main short coming of the postage stamp method is that it charges all users of the system based on a ratio of their contribution to the peak power level without taking into account the distance over which the energy is transported. A transmission user selling generated power to a customer near itself gains no advantage over a generator selling power remote to itself and as a result, this cost allocator does not produce economic signals that will properly influence the location of new generator plants. With this method a generator close to its own customer may decide to by-pass the existing transmission system all together. This will be pointed out when the benefits of the MW-Mile methods are discussed in section 2.3.2.4.

2.3.2.2 Contract Path Methods

The main deficiency with the contract path method is that it does not adequately represent the actual path over which transmitted energy travels. That is to say, it ignores the physics

associated with electrical transmission. Energy, when entering into a grid from a generator, divides up inversely based on the impedance it encounters in the lines and is not confined to the contract path selected. This problem is referred to as loop flow or the parallel path problem in the literature, [18]. Contract path methods do not adequately compensate neighboring utilities whose reserve system capacity is diminished by the wheel in question. This is the impetus behind FERC's suggestion for developing more credible costing methods

2.3.2.3 Boundary Flow Methods

The main shortcomings of the boundary flow methods are the same as the postage stamp method, in that the extent of use of the transmission system is not adequately reflected in the eventual price paid by the wheeling customer.

2.3.2.4 Megawatt Mile Allocators

The classic megawatt mile allocator proposed in reference [10] is an improvement over the postage stamp allocator. This is pointed out in the discussion when the author compares the two allocators based on a simple system. In that author's example, he compares two transactions, each 1000 kW, one is a short distance transaction using less system resources than the other transaction, which is long distance transaction. The postage stamp method would require each utility to pay the wheeling utility 50% of the system cost. Through the use of this version of the megawatt-mile approach, the short distance utility would be required to pay only 7 % of the system costs. The utility transmitting its energy a long distance would be required to pay 93 %. This is a more accurate reflection of the use of system resources. The main shortcoming of this methodology [10] is that system capacity is

a measure which reflects price. Transmission systems are almost always over designed. One of the reasons for this is system security. This is an asset which a user should pay for. However, another reason for over designing is simply related to the available voltage levels and conductor sizes available to the designer when considering an original design or upgrades, and the cost of performing upgrades year after year. This tends to make capacity values appear lumpy or discrete. As a result of pricing transmission access based on capacity, it is likely that all the installed capacity will not be used and as a result the revenue generated from wheeling transactions will under recover the needed dollars to support the system. As a result this method will produce stranded costs which are to be avoided [1]. In addition the issue of defining capacity has been raised by some others. Capacity can be defined based on thermal limits or on surge impedance loading. The Federal Energy Regulatory Commission has entered into a discussion on spare capacity in order to clarify issues relating to the proper determination of transmission capacity.

Happ in [11] improves on Shirmohammadi's idea in reference [10] for dividing up the costs of the system between users by basing the user's price on a percentage of total use by all, as opposed to capacity. With this approach, the total percentage of system use between users will always total to one. This will provide full recovery of costs, which is the desired objective. However in reference [11] the author divides up the cost of the total system between users, and does not divide up the costs on a facility-by-facility basis.

Kovacs in reference [13] improves on the work in [11] by dividing up the cost between users not on the system as a whole, but on a facility-by-facility bases, while at the same calculating the use of a line as the flow of a transaction divided by the sum of the flows. This avoids the capacity issue and ensures that the total of all the ratios of use will equal

one. The division of costs on a facility by facility basis between users ensures that the users of the more expensive portions of the system pay for such use. This is the most desirable method.

One of the issues common to all megawatt-mile indicators is the issue of what to do when a wheeling transaction indicates that there has been a reduction in line flow as a result of the wheel. This was pointed out in references [11,13]. The ratio of use can be simply formulated as;

$$\text{Ratio of use} = (\sum_i \Delta P_{ij}) / (\sum_i \sum_j \Delta P_{ij}) \quad (2.13)$$

There are three principal conditional changes in power flow on a line. These are as follows:

- 1) The sign associated with the power flow (direction) from the wheel is retained and when added to the predominant power flow, can cause a net increase or decrease in flow on the line in question.
- 2) The sign associated with the power flow (direction) from the wheel is discarded, so that only the absolute value is considered, and when added to the other power flows through the summation process will cause only a net increase.
- 3) Those wheels which cause a reduction of flow on the line in question are discarded and not included in the summation

In references [10,13] the absolute value approach, condition two above, has been used.

Reference [11] leaves this option open. One of the problems with condition 1 above is that it is possible for a wheeling customer to produce a negative value within the summation, this in turn would produce a wheeling credit. If the wheeling transaction under consideration reduces line loading but at the same time produces no alleviation of congestion, simply because no congestion existed, then the wheeling customer would receive a credit for alleviating a problem that never existed. However, there are instances when the reduction in congestion, resulting from the siting of generation such as to reduce the predominant flow in a part of the system, is beneficial. For such an action at that time,

it would seem appropriate that the generator receive credit for avoiding or delaying reinforcements. This can only be determined after a contingency analysis, where the generator commits to availability during those peak times when line reduction is required. However, the greater concept of rewarding system users, or penalizing system users, for reinforcements is not a concept consistent with embedded cost analysis. With embedded cost analysis no one user receives a penalty, or credit, for reinforcements. As a general rule, embedded cost allocators, and some others to be discussed, charge system users based on their contribution to the system peak. Generators transmitting without contributing to the peak flow receive lower access tariffs. Consistent with this philosophy those generators which reduce line flows, and as such are not contributing to system peak should receive reduced tariffs, making the third option realistic.

Another complication could exist if the summation in the numerator is permitted to be calculated while including the negative sign for those wheels which reduce load, while in the denominator the absolute value of all the changed flows were used in the summation. This complication would exist because the ratio of numerator to denominator would be less than unity thereby reducing the revenue input to the wheeling company. However, it is possible for the denominator to be calculated with the negative sign included.

2.3.2.5 Comments on all Embedded Methods

The advantages of embedded cost allocators are their obvious simplicity, with the postage stamp allocator being the simplest. Another advantage of the majority of the allocators is that, access fees are based on a percentage of system peak load. It is the system's peak load which determines the needed design capacity and cost. Wheeling at times other than peak period would produce a reduced access fee. This diversity diminishes the need for system

expansion, and makes better use of existing capacity. This standard demand side management concept was not brought out in the literature.

Embedded, and other methods, which apportion the cost of the existing system and reinforcements between users limit themselves to that. That is to say, they are allocators for dividing up the costs of the physical transmission plant only, and they in no way account for the line losses, generation dispatch, and var compensation that a system requires to permit it to function as a proper transmission system. However, having recognized this limitation another group of allocators have been constructed to account for these production issues. One such group of allocators are those titled short run marginal costs (SRMC).

In addition to the problem of production costs, economic considerations do not support the way which embedded methods include the cost of reinforcements into the calculations i.e. the fact that reinforcement costs get lumped in with the existing costs. Dispersing the costs of reinforcements between all users of the system is not economically justified as these costs are not properly charged to those users who force the upgrades to occur. Some embedded allocators are worse than others on this issue. The methods that roll the costs of upgrades in with the total costs of the existing system, such as the postage stamp method, the boundary flow method and some forms of the megawatt-mile indicators do this. With these methods, the percentage of the upgrade costs are then allocated to all system users regardless of the customer's electrical use of the upgrades. The flow mile method [13], is an improvement in this regard because it calculates the costs of the existing system and reinforcements on a facility-by-facility bases. Hence when upgrade costs are accounted for, they become included in only those facilities requiring the upgrades. As a result only the users of the particular upgraded piece of the system are charged with a portion of the

upgrade costs, not all customers. However, admittedly those existing customers on that part of the system would share in the costs of reinforcements. This does not conform with economic theory. Proper economic signals should be issued to those system users requiring the upgrades. This is where the concepts of what are called marginal and incremental cost analysis begins to be applied. Incremental cost analysis is the topic of the next section.

2.3.3 INCREMENTAL COSTS AND PRICING

In order to accommodate the wheeling company for the added expenses associated with upgrading a transmission system for additional loads, the increased costs are required to be converted into a tariff. The discussion of what costs are to be included in this tariff, and as to how these expenses are to be assembled before being divided between system users, varies depending on the cost allocation scheme used. In the last section the costs for the necessary additional physical structures, or upgrades, needed to make the system robust enough to handle these new and additional loads were included with the existing system costs either as an addition to the total sum of the existing system costs or as an increase to the cost of specific facilities. These reinforcement costs were then divided amongst new and existing customers. This is known as the embedded method. With the incremental approach to costing and pricing, the costs of reinforcements may be treated separately from existing system costs and charged to only those customers requiring the upgrades. In addition the added production costs are included in an incremental based electricity tariff.

Incremental costing methodologies are broadly classified into two types. They can either be classed as short run incremental costs, or they can be classed as long run incremental costs. The short run incremental cost form calculates only the added cost of new production on an incremental basis without regard for reinforcement costs. Long run incremental costing

calculates the total sum of all costs to the wheeling company for expenses incurred to accommodate the wheel. For long run incremental costing this includes the added cost of new physical reinforcements, additional operation and maintenance, and of new production, to be charged only to new customers on an incremental basis.

2.3.3.1 Short run incremental cost method

The short run incremental cost (SRIC) methods account for the total change in production costs experienced by the wheeling utility, associated with the new wheeling transactions that are being considered over the life of a specific least cost expansion study period. These total changes in production costs over the study period are estimated by performing optimal power flow (OPF) studies. Two OPF studies are conducted for the period over which future load growth is being considered. One is performed for that year in the study period when all wheeling transactions, and all physical reinforcement projects, are in place on the system, in order to determine the production costs at that point in time in the future. This total production cost will be designated as IPC_r . A second OPF study is conducted for some point in the study period that considers any reinforcements that were previously planned for this study period, but which are not the direct result of the new transactions being considered in this period. These are reinforcements that have been planned in advance and that would have been undertaken regardless of the findings in this present study. The production costs at this time, with the already committed reinforcements, will be designated as IPC_o . It is the difference between the total production costs IPC_r and the reference production costs IPC_o , that the wheeling utility will divide between those customers associated with the new additional future loads that were not previously considered.

$$\Delta IPC_t = IPC_t - IPC_t \quad (2.14)$$

Where, IPC_t are the total production costs of the wheeling utility at that time in the study period when all the wheels are being conducted and all the reinforcements are in place, expressed in \$/year,

IPC_t are the production costs associated with that point in the study period when any previously committed to reinforcements and wheels are present on the wheelers system, expressed in \$/year, and

ΔIPC_t is the difference between the above costs which will be shared between the new customers requiring increased capacity. Expressed in \$/year.

In order to determine access fees for customers, the allocation of these costs between the generators of these new wheeling loads will be explained in the sections dealing with incremental allocators in the long run incremental cost section, as follows.

2.3.3.2 Long Run Incremental Costs

Long run incremental costs (LRIC) account for the changes in production costs and the changes in infrastructure costs which are associated with the increased loads being considered in the study period. The changes in production costs are as outlined above. The changes in infrastructure costs are calculated via the use of least cost expansion methodologies.

Some of the long run incremental costing methods (LRIC) are listed as follows [11,17]

- 1) LRIC (dollar per MW allocation),
- 2) LRIC (dollar per MW Mile Allocation negative change),
- 3) LRIC (dollar per MW Mile Allocation magnitude addition),
- 4) LRIC (dollar per MW Mile Allocation only positive change), and
- 5) LRIC (interface flow by region).

For a specific study period, the required reinforcements, the time these specific reinforcements are needed, the associated capital investments, and the generating companies which initiated the requirements, are identified by the wheeling utility. In incremental analysis, the differences in total reinforcement costs over the study period are shared by the customers being considered in that study period. This is distinct from marginal cost analysis which only allocates a percentage of the total costs between customers. This total change in reinforcement costs is calculated by first determining the total costs associated with all the reinforcements that will be required as the result of all wheeling over the life of the study period. This will be designated as IRC_t . Secondly, the reinforcement costs associated with any upgrades that were previously scheduled to be performed over the course of the study period, regardless of the conclusions obtained from the present study, are identified. These reference costs will be designated as IRC_r . The difference of these reinforcement costs to be allocated between new customers is given as:

$$\Delta IRC_t = IRC_t - IRC_r \quad (2.15)$$

where, IRC_t is the total cost of all the reinforcements that will be constructed over the entire life of the study period. The cost of all reinforcements are brought back to year 1 of the study period, Expressed in \$/year,

IRC_r is the total cost of reinforcements that were previously scheduled to be undertaken during this study period as a result of previous studies and are not associated with any of the new wheels being considered. The cost of all these previously determined reinforcements are brought back to year 1 of the study period. Expressed in \$ / year, and

ΔIRC_t are the changes in reinforcement costs. Expressed in \$/year.

2.3.3.3 General Incremental costing concepts

The added costs for both reinforcements and production that will be incurred as a result of projects going on-line during different years over the course of the study period, are

required to be brought back to the first year of the study period for evaluation. By way of example, in a ten year study period different generation may go on-line in years one, three, and five, with the required reinforcement projects being constructed in years one and three. This will produce production costs changes in years one, three, and five, and reinforcement costs in years one and three. The upgrade in year three is designed to handle both of the generation projects slated for years three and five, as was determined by a least cost expansion study for this ten year period. Because these future reinforcement and production costs occur at separate years, and because incremental analysis allots the change in total costs over the study period, these costs all have to be evaluated at year one of the study period. This requires accounting considerations which include the spreading out of project costs over their life from the in service date to the end of their book life. This is done in order to determine annual costs over this period, and to then bring all of these annual costs, which start at the in service dates, back to year one of the study period. The total change in incremental reinforcement costs, ΔIRC_t , and the total changes in incremental production costs, ΔIPC_t , as used within, are assumed to have had the necessary economic analysis performed on them, i.e. present worth, depreciation, etc., to express them as a yearly value for each year of the study period.

In the following discussion, both production and reinforcement incremental costs will be considered. This is the long run incremental method. If the short run incremental method is of interest, then only the production costs should be considered in the evaluation of the allocators.

2.3.3.4 Dollar per MW Allocator, as applied to long run incremental pricing

The dollar per megawatt allocator is conceptually similar to the postage stamp allocator discussed in a previous section. Via this allocator, the total difference in reinforcement costs for the entire system, and the total difference in production costs for the entire system, over the course of the study period, are divided between the new system users. The division of these costs is based on each user's contribution to the total incremental load change. This is done to determine the annual price which each user will pay to the wheeling utility for its additional loads on the system.

$$IPR_{x,y} = (\Delta IPC_y + \Delta IRC_y) * (IP_{x,y} / IP_{tot}) \quad (2.16)$$

Where, $IPR_{x,y}$ is the total price user x pays for system use per year to accommodate his new load on the reinforced system,

$IP_{x,y}$ is user x's incremental power contribution on the system in year y, over the course of the study period. This may be zero for those years before he requires wheeling services, and

IP_{tot} is the sum of the magnitudes of each new load that will be introduced to the system over the study period.

2.3.3.5 Dollar Per Megawatt-Mile Allocator as applied to incremental pricing

This methodology is conceptually similar to the embedded megawatt-mile allocator proposed in an earlier section [11]. Via this allocator, two load flow studies are conducted for each year of the study, for each new wheel being undertaken, to determine the change in the flows on each line of the system that result from the new wheel. As before, for each new wheel, the change in line flows, in megawatts, and as indicated by the two load flows, is multiplied by the length of line l, in miles, over which the change occurs. This is done to determine the megawatt-mile contribution per line. This multiplication is done for all the lines in the system to determine the total change in megawatt-miles for each customer per

year. This can be expressed as:

$$\Delta \text{IMW Miles}_{x,y} = \sum_l \Delta \text{IMegawatts}_{x,l,y} * L_l \quad (2.17)$$

where, $\Delta \text{IMegawatts}_{x,l}$ is the change in the flow on line l (lower case L) as a result of the incremental change in system use by customer x during a particular year in the study. This will be zero for those early years in the study when the transactions have yet to take place. As stated in the embedded cost analysis this summation can take on various values depending on the treatment given to the change in flow. the change in value can be treated as either, absolute value, retain sign, or ignore if negative,

L_l is the length of line l (lower case L) in miles, and

$\Delta \text{IMW Miles}_{x,y}$ is the total change in Megawatt mile usage for customer x , for a particular year in the study.

The price paid by each customer per year is calculated as:

$$\text{PR}_{x,y} = (\Delta \text{IPC}_y + \Delta \text{IRC}_y) * \Delta \text{IMW Miles}_{x,y} / \sum_x \Delta \text{IMW Miles}_{x,y} \quad (2.18)$$

where, $\text{PR}_{x,y}$ is the total price user x pays in year y for wheeling services, and

$\sum_x \Delta \text{IMW Miles}_{x,y}$ is the total incremental megawatt miles on the system as a result of all wheeling requirements from all customers.

If desired, a similar incremental allocator can be constructed from Shirmohammadi's classical megawatt-mile allocator [10]. This will produce an allocator based on new installed capacity cost estimates, created from kV ratings, etc. However this allocator would not be as accurate and beneficial as the preceding since actual construction costs are readily available. Through the approach to the megawatt-mile methodology outlined in reference [13], the impacts of incremental flow changes on the system are evaluated on a facility-by-facility basis as opposed to a system wide basis. The change in flow on each line can be determined from successive load flows in year y . One load flow study with the wheel of company x

present, and another study without the wheeling increment. For an incremental analysis, the method in reference [13] can be re-formulated as:

$$PR_{x,y} = [\sum_f (\Delta IPC_f + \Delta IRC_f) * | \Delta MW_{f,x,y} | * IC_{f,y}] / \sum_f \sum_x | \Delta MW_{f,x} | \quad (2.19)$$

Where, $IC_{f,y}$ is the incremental cost of facility f in year y ,

$\Delta MW_{f,x,y}$ is the change in megawatt flow, on facility f , in year y , as a result of the incremental flow created by company x at the end of the study period, and

$\Delta MW_{f,x}$ is the change in megawatt flow on facility f , as a result of the incremental flow created by company x .

2.3.3.6 Interface Flow By Region, as it applies to long run incremental pricing

The interface flow by region cost allocator is very similar to the boundary flow allocator described earlier in the embedded costs section. This method requires the execution of two load flow studies to determine the difference in system tie line loading for each year of the expansion study. One load flow study is performed with the incremental flow included, and another study is performed without the incremental flow. This is done so that the difference in flows can be determined, and is somewhat similar to what was done in the dollar per megawatt allocator above. With this allocator the charge to the customer for changes in tie line flow is calculated as:

$$PR_{x,y} = (\Delta IPC_f + \Delta IRC_f) * [\Delta IP_{f,x,y} / (\frac{1}{2} \sum_x | \Delta IP_{f,x,y} |)] \quad (2.20)$$

where, $IP_{f,x,y}$ is the incremental flow over intertie I in year y , and

$IP_{f,x,y}$ is the incremental power contributed by company x , in year y .

2.3.4. DISCUSSION OF THE INCREMENTAL COST METHODS

2.3.4.1 Short Run Incremental Cost Allocator

As mentioned, short run incremental methods account only for changes in production costs, and as a result, are not suitable on their own for providing compensation for the physical infrastructure.

2.3.4.2 Dollar Per Megawatt Allocator

The main advantage of this form of allocator is its simplicity. However, the main shortcomings of the dollar per megawatt allocator are similar to those of the embedded postage stamp method. Through the use of this technique, no reflection of the extent of use of the reinforcements is considered. Given two simultaneous reinforcements, each electrically remote and of different value, in which you have one transaction using a minimal of the new resources, and another transaction using the vast majority of the reinforcements, both new customers would share in the added costs based only on the new power transmitted. The method does not draw a relationship between the extent to which each of the new reinforcements are used by each customer.

2.3.4.3 Dollar per Megawatt-Mile Allocator

The version of the megawatt-mile allocator in reference [11] is an improvement over the dollar per megawatt allocator above. This method recognizes the extent of use of the total system upgrades and divides the total cost of upgrades by a new customer's extent of use based on the Megawatt-miles used. However again, this method does not draw a direct correlation between a customer's use of an expensive upgrade, such as a buried or submarine cable, and the customer's use of a less expensive upgrade, such as the re-

conducting of a weak link. The megawatt-mile allocator in reference [13] is an improvement over that presented in [11] because it draws this connection between the cost of specific facility upgrades and a customer's use of this specific facility. However, all the megawatt-mile allocators are limited by the fact that many reinforcements may go in place before all users of these reinforcements will require them. As a result, some system users will be required to pay for the reinforcements before those users actually require them. However these latter users do have the choice to request their own up grades at the required time.

2.3.4.4 Interface Flow By Region

The advantages and disadvantages of this method are the same as that of the dollar per megawatt method.

2.3.4.5 Concluding Comments on all Incremental Methods

The main advantage of the incremental methods is that they force those companies which require reinforcements to pay for them. The economic consideration dictates that the added economic consequences will encourage new system users to be more responsible, especially in terms of generator site selection.

2.3.5 SHORT RUN MARGINAL COST ANALYSIS

The short run marginal cost (SRMC) of electricity, as it applies to wheeling, is the associated production costs of transmitting the last MW of power in a wheeling transaction, while not accounting for any costs related to the reinforcements that may be necessary in order to accommodate the wheel. The SRMC is calculated by conducting an optimal power flow (OPF) study on the system with the base case load and the wheeling

load present at the same time in the study. The OPF study will indicate the optimal cost of power at each bus on the system. The marginal cost per MW of transacted power becomes the difference in the cost of power at the bus where power is being injected, and the cost of power at the bus, or busses, where the power is being removed. The total cost of transmitted power then becomes the marginal cost per MW multiplied by the amount of power being transmitted.

$$SRMC_{ix} = [\sum_i \sum_r (MC_i - MC_r) * PB_{ixr}] \quad (2.21)$$

Where, MC_i is the optimal cost of power at the injection bus,

MC_r is the optimal cost of power at the receiving bus,

PB_{ixr} is power balance between the injected power at bus i and power removed at bus r by the customer x , and

$SRMC_{ix}$ is the total short run marginal cost for customer x .

2.3.6 DISCUSSION OF THE SHORT RUN MARGINAL COST METHOD

As pointed out in references [12, 19-22], short run marginal cost (SRMC) theory grossly fails to produce the revenue required to maintain and expand a transmission system. Reference [22] indicates that SRMC revenues can be as low as 15% of what is required to recover the capital costs, depending on system configuration. The inadequacies of SRMC can be explained simply as follows. SRMC revenues are directly dependent on system losses. An upgraded, less lossy system is more expensive to construct, yet under SRMC theory the revenues produced by this more expensive system, are less than that of a lossy system. In this sense the relationship between SRMC and system revenues is inversely proportional. It is well recognized that there is a need for supplementary cost allocations when employing SRMC to produce revenue reconciliation. The needed supplemental cost allocation can be achieved through the use of the embedded or incremental cost allocators, to account for the

cost of the system infrastructure.

Short run marginal cost theory is often applied to the combined assessment of generation and transmission costing [19].

CHAPTER 3

GENERALIZED PARTICIPATION FACTORS

3.0 INTRODUCTION

In a re-regulated industry, geographically dispersed transmission dependent customers are expected to avail of the new open access opportunities. This liberalized access to the transmission system will necessitate some means for estimating the magnitude and path of the current from the different sources in order to develop and implement some meaningful form of an open access tariff. There are a number of traditional methods used for estimating the effect of generation input on the power transfer in a transmission system. One of these traditional methods is implemented by performing two successive load flow studies on a system, one study with the wheel in question, and another study without, in order to determine the variance in flow on the lines in the system. Another approach for determining the path traveled by the current from a source is to perform a load flow study on the test system while the system contains only the wheel in question. However, another available method is created by extending the philosophy of the generation shift factors which are often used in security analysis. Generation shift factors are mathematical tools generally applied to a system load flow solution in order to determine the change in

power flow that would result on a particular line if a specific generator were to change its power output while at the same time requiring the swing bus to accommodate for this change. An extension of the generation shift factor philosophy will be presented as a method for tracing the flow of current from a generation source.

3.1 SIMPLE SYSTEM

For a typical electrical system the objective is to establish a relationship between the power injected / removed at a particular bus and the real power flow on transmission lines everywhere in the system. This relationship includes those lines and busses which are not directly connected. Via Kirchoff's current law, for the simple system of figure 1, which contains no phase shifters, tap changing transformers or other devices which regulate power flow, the following equations can be written for each bus;

$$I_1 = (E_1 - E_2) Y_d + (E_1 - E_3) Y_e + E_1 (Y_{1de} + Y_{1e}) \quad (3.1)$$

$$I_2 = (E_2 - E_1) Y_d + (E_2 - E_3) Y_f + E_2 (Y_{2de} + Y_{2e}) \quad (3.2)$$

$$I_3 = (E_3 - E_1) Y_e + (E_3 - E_2) Y_f + E_3 (Y_{3ec} + Y_{3e}) \quad (3.3)$$

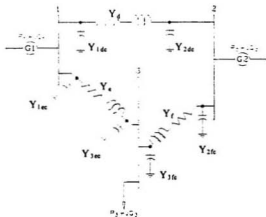

Figure 3.1 - Simple 3 bus system

Rearranging these equations produces,

$$I_1 = E_1 (Y_d + Y_e + Y_{1ec} + Y_{1dc}) + E_2 (-Y_d) + E_3 (-Y_d) \quad (3.4)$$

$$I_2 = E_1 (-Y_d) + E_2 (Y_{2dc} + Y_{2dc} + Y_f + Y_d) + E_3 (-Y_d) \quad (3.5)$$

$$I_3 = E_1 (-Y_e) + E_2 (-Y_f) + E_3 (Y_f + Y_e + Y_{3ec} + Y_{3ec}) \quad (3.6)$$

In matrix form these relationships can be re-written as,

$$\begin{bmatrix} I_1 \\ I_2 \\ I_3 \end{bmatrix} = \begin{bmatrix} Y_d - Y_e - Y_{1dc} - Y_{1ec} & -Y_d & -Y_e \\ -Y_d & Y_d - Y_f - Y_{2dc} - Y_{2dc} & -Y_f \\ Y_e & -Y_f & Y_e - Y_f - Y_{3ec} - Y_{3ec} \end{bmatrix} \cdot \begin{bmatrix} E_1 \\ E_2 \\ E_3 \end{bmatrix} \quad (3.7)$$

Where the central matrix is referred to as the Y_{bus} matrix. The quantities within the Y_{bus} are values from the representation of the transmission lines and as a result are dependent on the transmission line model used. The line model used in figure 1 is that of a medium length line, less than 240 km, typically called a π line representation. The normally distributed capacitance in the line is represented by two ideal capacitors, each of one half value to that of the total capacitance, placed at the ends of the line, terms Y_{1dc} or similar, in the matrix. A simplification of the medium line model is the short line model, less than 80 km, and is composed of only the series resistance and series inductance of the power line [23]. The short line model is the model that will be used in the derivation. The previous equation re-written with the simplified Y_{bus} matrix becomes,

$$\begin{bmatrix} I_1 \\ I_2 \\ I_3 \end{bmatrix} = \begin{bmatrix} Y_d - Y_e & -Y_d & -Y_e \\ -Y_d & Y_d - Y_f & -Y_f \\ -Y_e & -Y_f & Y_e - Y_f \end{bmatrix} \cdot \begin{bmatrix} E_1 \\ E_2 \\ E_3 \end{bmatrix} \quad (3.8)$$

or in summation format the relationships in the matrix can be expressed as;

$$[I_n] = \sum_1^M Y_{nm} E_m \quad (3.9)$$

Where, I_n is the value of current leaving bus n through the transmission system, it is a complex quantity, $|I_n| \angle \theta$,

E_n is the value of voltage at bus n , it is a complex quantity, $|E_n| \angle \theta$,
 $\angle \theta$ is the angle of the quantity in question, referenced to the swing bus
 Y_{nm} are admittance values which come from the admittance matrix above, termed Y_{bus} , (the bus subscript is used to indicate that the admittance's are based on KCL as opposed to KVL which would create a matrix termed Y_{loop}). $Y_{nm} = (Z_{nm} \angle \theta)^{-1} = G + jB$. G is conductance, B is susceptance.

For $n=m$ Y_{nm} is called the driving point admittance and numerically is the sum of all the admittance's connected to bus n (or m), and

For $n \neq m$ Y_{nm} is called the transfer admittance and numerically is equal to the negative of the value of admittance connecting bus n to bus m .

Given the fact that the quantity of both real power, P , and reactive power, Q , are known for all busses except the slack bus, another group of equations can be created to help solve for line flows. (P and Q are calculated at the slack bus to account for system losses and unmatched generation). The equation for the apparent power leaving bus n , is given as follows,

$$S_n = P_n + jQ_n = E_n I_n^* \quad (3.10)$$

Substituting into equation (3.10) the equation for the sum of the currents leaving the bus, equation (3.9), produces,

$$S_n = P_n + jQ_n = E_n (\sum_1^M Y_{nm} E_m)^* \quad (3.11)$$

The expression in equation (3.11) indicates that the apparent power leaving bus n is equivalent to the sum of the apparent power on the transmission lines attached to the bus.

Expanding equation (3.11) into its rectangular form and equating the real terms to themselves, and the imaginary terms to themselves, produces.

$$P_n = \sum_i^M |E_n| |E_m| [G_{nm} \cos(\theta_n - \theta_m) + B_{nm} \sin(\theta_n - \theta_m)] \quad (3.12)$$

$$Q_n = \sum_i^M |E_n| |E_m| [G_{nm} \sin(\theta_n - \theta_m) - B_{nm} \cos(\theta_n - \theta_m)] \quad (3.13)$$

The values P and Q are related, however, the effect of a change in power injected at a bus produces only a slight effect on the value of reactive power Q produced, and vice-versa. Thus the solutions to these two equations can be solved independently to determine line flows. This philosophy is utilized in the dc load flow solution technique which in turn is a further simplification of the fast de-coupled load flow solution technique. The technique is termed dc because no values for volt-amps or vars are obtained from the solution [24,25]. An advantage of the dc technique is that it is linear. Ideally the relationship between megawatt flow and power injection or removal is nonlinear, as in the ac solution, however dc solutions provide excellent approximations [13]. With this approach, the expression for P_n in equation (3.12) will be analyzed without regard for Q_n , in equation (3.13).

3.2 NEWTON'S METHOD

The most popular solution technique for determining the solution to a group of nonlinear equations with structures similar to equation (3.13) is the Newton technique, more specifically the Newton-Raphson technique. The Newton-Raphson technique is an extension of the Newton method and is designed for solving a group of simultaneous equations, whereas the classical Newton method is designed for obtaining the roots of a single equation. Both are iterative techniques. The Newton iterative method and how it applies to the power system equation of (3.12) is described to present the philosophy of the Newton-Raphson technique.

Newton's iterative technique works on a single equation by solving for the power mismatch at the bus in question. For all practical purposes, all the energy entering a bus via the

transmission system is equal to the energy leaving the bus via the transmission and distribution systems and as a result the power mismatch is zero. By viewing figure 3.2 it can be seen that the 4 watts generated is consumed by the 1 ohm resistor. The objective is to determine the quantity of current, I.

$$F(x) = P = I^2 \cdot R \quad (3.14)$$

$$4 = I^2 \cdot 1 \text{ ohm} \quad (3.15)$$



Figure 3.2 - Simple 1 bus system

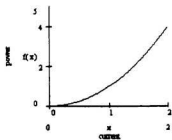

Figure 3.3 - function

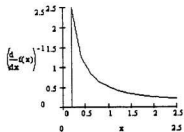

Figure 3.4- derivative of function inverse

Through the use of Newton's solution technique an initial estimate for I, termed I_0 , is made in order to determine the power which such an estimate would produce. In this

simple example an initial estimate of $I_0 = 1.5A$ produces 2.25 watts of power, $f(I_0) = 2.25W$. The initial estimate made for I produces a power mismatch, termed ΔP_0 , which is calculated by subtracting the value of wattage produced by the estimate for I from the known value of the result. For this example ΔP_0 would be 4 watts less the value of 2.25 watts which equates to 1.75W. The value ΔP_0 indicates the accuracy of the estimate. If desired, another more accurate estimate for I can be generated by multiplying the value for ΔP_0 created by the estimate for I , by the inverse of the derivative of the original function evaluated at the point of the estimate and then to add this value of current, ΔI , to the original estimate for I . For this example, the inverse of the original function, $P=I^2$ is $I = \sqrt{P}$. The derivative of the inverse $[df(i)/d(i)]^{-1}$, is $(d(i)/df(I)) = 1/2 P^{-1/2}$, and is shown in figure 3.4. This expression, evaluated at P equal to 2.25W, produces $0.333 \Delta I/\Delta P$. The value of the inverse multiplied by the ΔP of 1.75W from the previous estimate for I produces a value of ΔI equal to 0.583A. This value of ΔI when added to the previous estimate of 1.5A produces a new estimate, I_1 , of 2.083A. The new value for I is then used to calculate the power developed in the resistor in order to determine the accuracy of I . This process is repeated until two consecutive values for I are close enough together to satisfy the user. In other words, the process is continued until ΔI , is less than a specified tolerance. This final value for I is the value for the current in the resistor. For this simple example, the correct value of current is 2 amps.

3.3 GENERATION PARTICIPATION FACTORS

For the power system relationship in equation (3.12), the equation can be restructured for the application of Newton's method, and can be re-arranged to become similar to:

$$P_2 = f(\theta_j) + [df(\theta_j)/d\theta_j] \Delta\theta \quad (3.16)$$

Where, $f(\theta_j)$ is the power produced from the previous estimate for θ ,
 $df(\theta_j)/d\theta_j$ relates power to phase angle,
 $\Delta\theta$ relates the modification to θ to adjust power.

Re-written to express θ in terms of the inverse derivative to modify the previous expression for θ produces:

$$\Delta\theta = [d\theta/dP_j] [P_2 - P_1] \quad (3.17)$$

Where, $P_2 - P_1$ is the error, or difference between estimates

In order to produce expressions similar to equations (3.16, 3.17) from the expression for power in equation (3.12), the expression in (3.12) can be first expanded to produce:

$$P_n = \sum_{m=1}^M |E_n| |E_m| [G_{nm} (\cos\theta_n \cos\theta_m + \sin\theta_n \sin\theta_m) + B_{nm} (\sin\theta_n \cos\theta_m - \cos\theta_n \sin\theta_m)] \quad (3.18)$$

At this point ideally it would be required to perform partial differentiation on equation (3.18) with respect to 4 different variables, 2 of these variables are voltage magnitudes E_m and E_n , and the other 2 variables are voltage angles θ_m and θ_n . However, as stated before, it has been shown that the sensitivity of power flow on transmission lines to slight changes in voltage magnitude at the terminating busses is small relative to the angular position of these voltages. Hence the derivatives of the power equation with respect to voltage magnitude will be small and will not be considered [24,25]. The two remaining derivatives of the power equation, one with respect to the voltage angle θ_n and the other with respect to voltage angle θ_m , are derived separately as follows:

$$\partial P_n / \partial \theta_m = |E_n| |E_m| \{ G_{nm} [-\cos\theta_n \sin\theta_m + \sin\theta_n \cos\theta_m] + B_{nm} [-\sin\theta_n \sin\theta_m - \cos\theta_n \cos\theta_m] \} \quad (3.19)$$

$$\begin{aligned} \partial P_n / \partial \theta_m = & |E_n| |E_m| \{G_{nm} [-\frac{1}{2} (\sin(\theta_n + \theta_m) + \sin(\theta_m - \theta_n)) + \\ & \frac{1}{2} (\sin(\theta_n + \theta_m) + \sin(\theta_n - \theta_m))] + B_{nm} [-\frac{1}{2} (-\cos(\theta_n + \theta_m) \\ & + \cos(\theta_n - \theta_m)) - \frac{1}{2} (\cos(\theta_n + \theta_m) + \cos(\theta_n - \theta_m))] \} \end{aligned} \quad (3.20)$$

$$\begin{aligned} \partial P_n / \partial \theta_m = & |E_n| |E_m| \{G_{nm} [-\frac{1}{2} \sin(\theta_m - \theta_n) + \frac{1}{2} \sin(\theta_n - \theta_m)] + \\ & B_{nm} [-\frac{1}{2} (2 \cos(\theta_n - \theta_m))] \} \end{aligned} \quad (3.21)$$

$$\begin{aligned} \partial P_n / \partial \theta_m = & |E_n| |E_m| \{G_{nm} [-\frac{1}{2} \sin(\theta_m - \theta_n) + \frac{1}{2} \sin(\theta_n - \theta_m)] - \\ & B_{nm} [\cos(\theta_n - \theta_m)] \} \end{aligned} \quad (3.22)$$

$$\begin{aligned} \partial P_n / \partial \theta_m = & |E_n| |E_m| \{G_{nm} [\sin(\theta_n - \theta_m)] - B_{nm} [\cos(\theta_n - \theta_m)] \} \end{aligned} \quad (3.23)$$

Similarly,

$$\begin{aligned} \partial P_n / \partial \theta_n = & |E_n| |E_m| \{G_{nm} [\cos\theta_n \cos\theta_m + \sin\theta_n \sin\theta_n] - \\ & B_{nm} [-\sin\theta_n \cos\theta_m + (\cos\theta_n \sin\theta_m)] \} \end{aligned} \quad (3.24)$$

$$\begin{aligned} \partial P_n / \partial \theta_n = & |E_n| |E_m| \{G_{nm} [\frac{1}{2} (\cos(\theta_n + \theta_m) + \cos(\theta_n - \theta_m)) + \\ & \frac{1}{2} (-\cos(\theta_n + \theta_m) + \cos(\theta_n - \theta_m))] - \\ & B_{nm} [-\frac{1}{2} (\sin(\theta_n + \theta_m) + \sin(\theta_n - \theta_m)) + \\ & \frac{1}{2} (\sin(\theta_n + \theta_m) + \sin(\theta_m - \theta_n))] \} \end{aligned} \quad (3.25)$$

$$\begin{aligned} \partial P_n / \partial \theta_n = & |E_n| |E_m| \{G_{nm} \cos(\theta_n - \theta_m) - B_{nm} [-\frac{1}{2} \sin(\theta_n - \theta_m) \\ & - \frac{1}{2} \sin(\theta_n - \theta_m)] \} \end{aligned} \quad (3.26)$$

$$\begin{aligned} \partial P_n / \partial \theta_n = & |E_n| |E_m| \{G_{nm} \cos(\theta_n - \theta_m)\} + B_{nm} \sin(\theta_n - \theta_m) \} \end{aligned} \quad (3.27)$$

Prior to placing these two derivatives into a matrix form for the solution of simultaneous equations as is required for a power flow solution, where the matrix inversion will be carried out to obtain $(\partial_p/\partial \theta)^{-1}$, a number of simplifications will be made to the expression.

The simplifications are as follows:

- 1) for small angles the cosine of the angle is equal to 1. Generally on a transmission system the angles at adjacent busses are small (< 10 degrees). As a result this simplification will be used.
- 2) for small angles the sine of the angle (in radians) is generally equal to the radian measure. As a result, angles of less than 10 degrees (.175 radians) the sine function can be removed from the equation.

As a result of employing these two simplifications, equations (3.23) and (3.27) reduce to the following:

$$\partial P_n / \partial \theta_m = |E_n| |E_m| \{ G_{mn} (\theta_n - \theta_m) - B_{mn} \} \quad (3.28)$$

$$\partial P_n / \partial \theta_n = |E_n| |E_m| \{ G_{nn} + B_{nn} (\theta_n - \theta_m) \} \quad (3.29)$$

Inspection of equations (3.28) and (3.29) indicates that the magnitudes of the slopes of the two equations (derivatives) are equivalent and the only difference in the two expressions is the sign or direction associated with the slope. Equation (3.27) expresses the change in power at a given bus n for a change in voltage phase angle at an adjoining bus m. It can be seen that for an advance in phase angle at the adjoining bus m, an increase in k units of power will flow into bus n. This is a positive change in flow as far as bus n is concerned. Equation (3.29) expresses the change in power at bus n for a given change in voltage phase angle at the same bus. It can be seen that for the same advance in phase angle, as was used previously for m, but now at bus n, the same change of k units of power will flow. However the flow is now out bus n, and over the line to bus m. This is a change in negative flow, from the perspective of bus n. The same magnitude of flow change occurs.

However, it is at a different direction.

Restating the objective of the derivation, given two arbitrary adjacent buses in a system, the objective is to determine the flow between these two buses for an injection/ removal of power at a remote bus. Equations (3.28) and (3.29) provide part of the mechanism for achieving this and will be set aside for the moment to examine another relationship associated with the flow of power in a transmission system and which is needed in the derivation.

For a transmission line an approximate equation for real power flow over a line joining buses D and E, (m and n are not used to emphasize the fact that transmission line d-e is not connected to buses m or n) can be expressed as;

$$P_{de} = (|E_d| |E_e| \sin(\theta_d - \theta_e)) / X_{de} \quad (3.30)$$

where X_{de} is the imaginary component of the impedance of line de. Line resistance is neglected

An expression for the change in power flow over a transmission line can be written as,

$$\Delta P_{de} = [|E_d| |E_e| \sin(\Delta\theta_d - \Delta\theta_e)] / X_{de} \quad (3.31)$$

Using again, the simplification that for small angles $\sin x \approx x$, equation (3.31) simplifies to

$$\Delta P_{de} = [|E_d| |E_e| (\Delta\theta_d - \Delta\theta_e)] / X_{de} \quad (3.32)$$

Hence an equation for $\Delta P_{de} / \Delta P_n$, which expresses the power change on a line with respect to power change at a bus, can be written by multiplying both sides of equation (3.32) by $1/\Delta P_n$. This multiplication produces the following equation;

$$\Delta P_{de} / \Delta P_n = [|E_d| |E_e| (\Delta\theta_d - \Delta\theta_e)] / [X_{de} \Delta P_n] \quad (3.33)$$

Re-writing equation (3.33) produces:

$$\Delta P_{de} / \Delta P_n = \{ |E_d| |E_e| / X_{de} \} \{ (\Delta \theta_d / \Delta P_n) - (\Delta \theta_e / \Delta P_n) \} \quad (3.34)$$

Drawing on the relationship set aside earlier, equation (3.28), and inverting it produces:

$$\partial \theta_m / \partial P_n = 1 / [|E_n| |E_m| (G_{nm} (\theta_n - \theta_m) - B_{nm})] \quad (3.35)$$

Bringing together the two relationships derived by substituting equation (3.35) into equation (3.34), and modifying subscripts for clarity produces:

$$\Delta P_{de} / \Delta P_n = \{ |E_d| |E_e| / X_{de} \} \{ (1 / [|E_n| |E_d| (G_{nd} (\theta_n - \theta_d) - B_{nd})]) - (1 / [|E_n| |E_e| (G_{ne} (\theta_n - \theta_e) - B_{ne})]) \} \quad (3.36)$$

If it is assumed that for a typical system, the magnitudes of bus voltages are relatively close to one another (typically less than .05 p.u.) $E_e / E_n \cong 1$. Equation (3.36) then simplifies to:

$$\Delta P_{de} / \Delta P_n = [1 / X_{de}] \{ 1 / [G_{nd} (\theta_n - \theta_d) - B_{nd}] - [1 / [G_{ne} (\theta_n - \theta_e) - B_{ne}]] \} \quad (3.37)$$

For a typical system the value of B_{12} is 10 - 15 times the value of $G (\theta_1 - \theta_2)$. Equation (3.37) simplifies to:

$$\Delta P_{de} / \Delta P_n = [1 / X_{de}] \{ [-1 / B_{nd}] - [-1 / B_{ne}] \} \quad (3.38)$$

However, $X = 1/B$. Using this relationship equation (3.38) simplifies to:

$$\Delta P_{de} / \Delta P_n = [1 / X_{de}] \{ [-X_{nd}] - [-X_{ne}] \} \quad (3.39)$$

Equation (3.39) expresses the change in flow on line d-e as a function of the power leaving bus n. However the ultimate objective is to express the change in flow from bus d to bus e as a function of the output of a generator n, or in other words as a function of the energy entering a bus. Hence, by maintaining sign convention, at generator bus n, $-G_n = P_n$. Rewriting equation (3.39) in terms of a generator's output produces.

$$\Delta P_{de} / \Delta G_n = -(-X_{nd} - (-X_{ne})) / X_{de} \quad (3.40)$$

It is to be noted that the values for impedances in the numerator of equation (3.40) are derived from the inverse of the Y_{bus} matrix and that the values for impedance in the denominator of equation (3.40) are the impedance for the line over which the power flow is to be determined.

Equation (3.40) shows that the relationship between the power flow in a transmission line and the power injected into the system from a generator, is primarily dependent upon the impedance between busses, and as a result, system configuration.

Rewriting equation (3.40) produces;

$$\Delta P_{de} = A_{de,n} \Delta G_n \quad (3.41)$$

Where $A_{de,n}$ is defined to represent the change in real power flow on line d-e for every real unit of generation change at generator n where:

$$A_{de,n} = (X_{nd} - X_{ne}) / X_{de} \quad (3.42)$$

Equation (3.40) however is not without limitations. It is a derivative relationship that expresses the change in power flow in a line which results from a change in generation at a bus. The objective of this derivation is to find an expression that is accurate for drawing a relationship between the total flow on a transmission line and the total output of a generator, not just for the changes in line flow that result from changes in generator output. This can be achieved by generalizing a particular solution. Let the general solution to be derived take the form,

$$P_{de} = \sum_1^N C_{de,n} G_n \quad (3.43)$$

or

$$P_{de} = \sum_1^N D_{de,n} L_n \quad (3.44)$$

where; $C_{de,n}$ is a constant that relates the power flow on line d-e to the generation of G_n .
 $C_{de,s}$ is a constant that relates the power flow on line d-e to the load L_n .
 G_n is the real power output of generator n, and
 L_n is the real power load at all load buses n.

The summation is to be performed over all the generators or loads (but not both) to determine the total line flow from the contributions of all generators/loads.

The relationship in equation (3.40) represents the change in real power flow on a particular line that results from a change in generation on a bus. If the changes in system losses that occur with a change in generation shifting are ignored, and if the load at the buses is held constant, so as to maintain the same total generation in the system, equation (3.43a) can be used to represent the change in real power flow on a line while generation is reduced at one bus and equally compensated for by another bus. In keeping with standard practice, the slack bus will be used to provide the difference in generation. Reducing generation at a particular bus n and compensating for this loss by increasing the output of the swing bus generator produces:

$$\Delta P_{de} = -(C_{de,n} \Delta G_n) + (C_{de,s} \Delta G_s) \quad (3.45)$$

Where, ΔG_n is the change in generation on bus n, and is equal to the negative of the change at the slack bus, $-\Delta G_s$, and
 $C_{de,n}$ and $C_{de,s}$ are the coefficients that reflect the change in MW flow on line d-e for changes in generation at the arbitrary bus n, and the slack bus s.

Similarly, equation 3.41 can be used to account for equal and opposite injections at the slack bus and another selected bus as follows:

$$\Delta P_{de} = -A_{de,n} \Delta G_n + A_{de,s} \Delta G_s \quad (3.46)$$

Equations (3.41) and (3.47) represent the same generation and line flow change

relationship. Therefore equating both equations (3.45) and (3.46) produces:

$$-A_{de,n} \Delta G_n + A_{de,s} \Delta G_s = -C_{de,n} \Delta G_n + C_{de,s} \Delta G_s \quad (3.47)$$

For the equal and opposite injection at the selected bus and the slack bus the following holds:

$$|\Delta G_n| = |\Delta G_s| \quad (3.48)$$

Hence equation (3.47) simplifies to:

$$-A_{de,n} + A_{de,s} = -C_{de,n} + C_{de,s} \quad (3.49)$$

$$C_{de,n} = C_{de,s} + A_{de,n} - A_{de,s} \quad (3.50)$$

In addition, another group of relationships can be produced, to determine the value for the constants $C_{de,n}$ and $C_{de,s}$. The extreme case of equation (3.41) can be taken by reducing the production at all generator busses to zero, thereby forcing the slack bus to pick up the load of the entire system. As a result of the shift in generation, the change in flow on line d-e that results from all the load being serviced from the slack bus produces:

$$\Delta P_{de} = P_{de,slack} - P_{de,(solution)} = \sum_{n \neq \text{slack}}^N A_{de,n} (-G_n) + \sum_{n \neq \text{slack}}^N A_{de,s} G_n \quad (3.51)$$

Where, $P_{de,slack}$ is the real power flow on line d-e after all the generation has been shifted to the slack bus,
 $P_{de,solution}$ is the flow on the lines before the shifts

For the general form of the equation to remain true and for equation (3.51) to be true, the following would have to hold;

$$P_{de,slack} = C_{de,slack} G_{slack} \quad (3.52)$$

However, equation (3.51) shifts all generation to the slack bus. Therefore it can be said that the generation at the slack bus is now equal to the sum of the generation from all the generators before the shift. If the change in losses are neglected,

$$G_{slack} = \sum_1^N G_n \quad (3.53)$$

Substituting equation (3.53) into equation (3.52) produces:

$$P_{de,slack} = C_{de,slack} \sum_1^N G_n \quad (3.54)$$

Substituting equation (3.54) into equation (3.51) and rearranging produces:

$$C_{de,slack} \sum_1^N G_n = P_{de,(solution)} - \sum_2^N A_{de,n} G_n + \sum_2^N A_{de,s} G_n$$

n≠ slack on RHS. (3.55)

Further re-arrangement to equation (3.55) produces:

$$C_{de,slack} = (P_{de,(solution)} - \sum_2^N A_{de,n} G_n + \sum_2^N A_{de,s} G_n) / \sum_1^N G_n$$

n≠ slack in numerator (3.56)

Substituting equation (3.56) into equation (3.49) produces:

$$-A_{de,n} + A_{de,s} = -C_{de,n} + (P_{de,(solution)} - \sum_2^N A_{de,n} G_n + \sum_2^N A_{de,s} G_n) / \sum_1^N G_n$$

n≠ slack in numerator (3.57)

Rearranging produces:

$$C_{de,n} = A_{de,n} - A_{de,s} + (P_{de,(solution)} - \sum_2^N A_{de,n} G_n + \sum_2^N A_{de,s} G_n) / \sum_1^N G_n$$

n≠slack in numerator (3.58)

Where; $A_{de,n}$ can be solved from the inverse jacobian of the power system configuration of the original load flow, equation (3.42),
 $P_{de,(solution)}$ are the real power flows as calculated in the original load flow,
 $\sum_1^N A_{de,n} G_n$ can be calculated once from the load flow results and generation settings (n≠ slack), and
 $\sum_1^N G_n$ is the total system generation at the time of the load flow study

As a means for checking the results to the solution of equation (3.57), the results of the original system study can be used. The following particular solution must hold:

$$P_{de,(solution)} = \sum_1^N C_{de,n} G_n \quad (3.59)$$

Where, $P_{dn, (solution)}$ are the solutions to the original load flow study on which A_{dn} were determined.

Having established the contributions made by each generator to the total power flow in any particular line, it then becomes possible to determine each generator's contribution to the load at any particular bus. For any load bus N, the following equation holds true:

$$L_n = \sum_1^D P_{dn} \quad (3.60)$$

Where, L_n is the real power load at bus N, and P_{dn} is the power flow in any line connected to bus N.

Each expression for real power can be re-written to express the power as the sum of contributions from different sources. For bus N we can write:

$$\sum_1^G L_{n,g} = \sum_1^G \sum_1^D P_{dn,g} \quad (3.61)$$

Where, $L_{n,g}$ is the real power load at bus n contributed by generator g, and $P_{dn,g}$ is generator g's contribution to the real power flow in any line connected to bus N.

Hence, a generator's contribution to the load at bus N can be determined by choosing a specific generator number g, and can be written as:

$$L_{n,g} = \sum_1^D P_{dn,g} \quad (3.62)$$

The results from Equation (3.56) are comparable to the system load flow solutions.

It is expected that equations relating the absolute flow on a transmission line to the output of generators can be derived by using another group of linear shift factors known as line outage factors. This is considered to be beyond the scope of this thesis.

3.4 LOAD PARTICIPATION FACTORS

While the relationship derived establishes a correspondence between the flow on particular lines and the energy inputted to the system by generators, another relationship, based on

similar philosophy, can be obtained to determine a correspondence between the flow on particular lines and the power drawn from the system at load buses. An alternate expression such as this may have value in a re-regulated electrical industry.

The cost of electricity transportation is dependent to some extent on the location of the sending and receiving busses. Depending on the form of generation, restrictions such as cooling water and emissions may establish a greater influence on the site of the generation than on the location of the energy consumer's facilities. Because of this greater flexibility large energy customers may be interested in establishing the relationship between the cost of energy and the selected geographical site. Without outlining the derivation, wheeling costs derived from the location of the load busses can be shown to be:

$$P_{de} = \sum_1^N D_{de,n} L_n \quad (3.63)$$

Where, P_{de} is the flow on line D-E, as before,
 $D_{de,n}$ is the constant that relates the load on line D-E to the load at bus n, and
 L_n is the real component of the power load at bus n.

For the equation (3.63) above $D_{de,n}$ can be shown to be:

$$D_{de,n} = A_{de,r} - A_{de,s} + (P_{de, (solution)} - \sum_2^N A_{de,n} L_n + \sum_2^N A_{de,r} L_r) / \sum_1^N L_n$$

n≠ slack in numerator \sum (3.64)

Where $A_{de,r}$ and $A_{de,s}$ can be solved from the inverse Jacobian of the power system configuration of the original load flow, equation (3.42), where R is the reference bus
 $P_{de, (solution)}$ are the real power flows as calculated in the original load flow,
 $\sum_2^N A_{de,n} L_n$ can be calculated once from the load flow results and the load at busses (n≠ slack), and
 $\sum_1^N L_n$ is the total system load at the time of the load flow study.

The similarity in the derivations of equations (3.63-3.64), and equations (3.58-3.59) can be

understood by viewing the sign convention associated with load power and generated power at system busses.

CHAPTER 4

APPLICATION AND DISCUSSION

4.0 INTRODUCTION

The formulations derived in chapter 3 are applied to a modified IEEE 14 bus system to determine the suitability of the developed methodologies for discerning the contributions made by each generator to the total load flow on each transmission line in the test system.

4.1 TEST SYSTEM

The tests were applied to a modified IEEE 14 bus system. The system data is contained in appendix A. The bus system was modified as follows:

- 1) The original IEEE system contains both generation and load on the second bus in the system. In an effort to separately analyze the load and generation components of current entering and leaving a particular bus the generation at bus number 2 was relocated. A new bus, number 16 was introduced and connected radially to bus number 2. A new transmission line, joining these 2 buses was then added to the system data. The effect of relocating the generation at bus number two in no way influences the accuracy of the results. However, idealizing each bus in the system as either a generation or load bus does improve the clarity of the results and does more easily permit the analysis of accuracy. The generation at bus number 2 was relocated to bus number 16 to attain the above stated objective.
- 2) The original IEEE 14 bus system contains only two generation sources, one at bus 1 and another at bus 2 in the system. In an effort to more completely check the formulations derived in chapter 3 a third generator was added to the system. This third system generator was placed at bus number 8. The original configuration contains only a static capacitor at bus 8 and no load is present. The capacitor was replaced with generation. The contribution made by this new generator to the load flows of the system are opposite to that of the predominant flows offered by the generation at buses 1 and 16 and helps

better represent the random flow in a system. Bus 8 is attached to the main portion of the system through a radial feed.

- 3) In addition bus 1 of the IEEE 14 bus system was renumbered bus 15 and the swing generator was placed at a new reference bus 1 which is connected radially to the new bus 15. The transmission line connecting these 2 busses was then added to the system data.



Figure 4.1- Modified IEEE 14 bus system single line diagram

The solutions to the system studies were achieved through the use of a DOS based load flow program that accompanies the student text titled "Power System Analysis and Design With Personal Computer Applications" by Glover, Sarma, and Digby, reference [47]. In addition, a utility present in the MicrosoftTM Windows version of a later revision to the same program was used to perform the inverse matrix operation on the bus admittance matrix. The system base chosen was 100 MVA. The swing bus starting value was set to 1.005 p.u. The remaining generation busses were configured for voltage regulation at 1.0 p.u.

Generation available var supply was established at a limiting p.f. of ± 0.8 . The calculations for determining the line contributions through the method illustrated were all performed in Microsoft[™] Excel spread sheets. Appendix D contains the cell formulae.

4.2 TEST PROCEDURE

Five system studies were performed. The raw data and the load flow solution printouts are provided in appendix B, tables B1 - B5. The first study performed is a base case study containing the installed load, generation and line impedances identified with the modified 14 bus system, with the exceptions identified above. The generation at bus 8 was randomly chosen to be 0.07 p.u. The impedance of the two new lines was randomly chosen to be $Z = 0.03 + j0.1$.

The second and third system studies performed simulate a system experiencing a uniform uplift to that of the base case. The second study contains load and generation settings that are twice that of the base case. The third system study contains loads and generation settings that are three times to that of the base case. These first three studies when analyzed together, simulate a system in which equivalent droop settings are applied to the governors of each machine for the purpose of load sharing. Table groupings C.1 - C.3 in appendix C and figures 4.5 - 4.7 include the results associated with these tests.

The fourth and fifth system studies contain the initial system generation settings that are present in the base case, and are fixed at the non-swing busses, as if to have their load limiters set so as to be unaffected by loading. For these simulations however, the demands at the load busses are incrementally increased to be twice to that of the base case for study four, and three times to that of the base case in study five. The first, fourth and fifth studies, when considered together, represent a system which contains non-swing bus

generators which produce constant output while requiring the generation at the swing bus to accommodate the change in loading. Table groupings C.1, C.4 - C.5, as well as figures 4.8 - 4.10, indicate the results associated with this group of tests.

The formulations of chapter 3 are applied to the system solutions to determine the contributions made by each generator to the total current on a particular line. The method for determining the contributions are illustrated in figure 4.3 and are as follows:

- 1) The inverse to the Y_{bus} admittance matrix was calculated from the system line data using $Z=0R + jX$ as the line impedance, resistance is neglected.
- 2) The 'A' factors for each of the generators were calculated from the inverse matrix and the line data (three in this case) using equation (3.42) from chapter 3 as:

$$A_{de,n} = (X_{nd} - X_{nr}) / X_{de} \quad (4.1)$$

This was done once and was used in all scenarios dealing with the system.

- 3) For a particular load flow solution the swing bus (reference bus) participation factor is calculated for the scenario in question using the 'A' factors from the system configuration as well as the line flow results and, each of the generators MW output as identified in the system load flow study. The participation factor for the reference bus is calculated using equation (3.56) of chapter 3 as;

$$C_{de,slack} = (P_{de,(solution)} - \sum_2^N A_{de,n} G_n + \sum_2^N A_{de,n} G_n) / \sum_1^N G_n \quad (4.2)$$

n≠ slack in numerator

This is done once for each test case from the information in the load flow solution.

- 4) For the case in question the participation factors for each generator, relating the current injected from the generator to the flow in each line (22 in these cases) are calculated using equation (3.58) in chapter 3 as:

$$C_{de,n} = A_{de,n} - A_{de,n} + (P_{de,(solution)} - \sum_2^N A_{de,n} G_n + \sum_2^N A_{de,n} G_n) / \sum_1^N G_n \quad (4.3)$$

n≠ slack in numerator \sum

- 5) A particular generator's contribution to the power flow on each line is calculated by multiplying a particular generator's output, as is indicated by the load flow results, by that generators participation factor for all the lines in the system.

- 6) Step 5 is repeated for each generator in the system
- 7) The contribution made by each generator to the current in a line are added together on a line by line, and generator-by-generator, basis to establish the total current on each line.
- 8) The contribution made by each generator to the current in a line are added at each load bus for all the incoming and outgoing lines at that bus to determine each generators contribution to the load at that bus.
- 9) Steps 3 to 8 were repeated for each of the other 4 case studies.

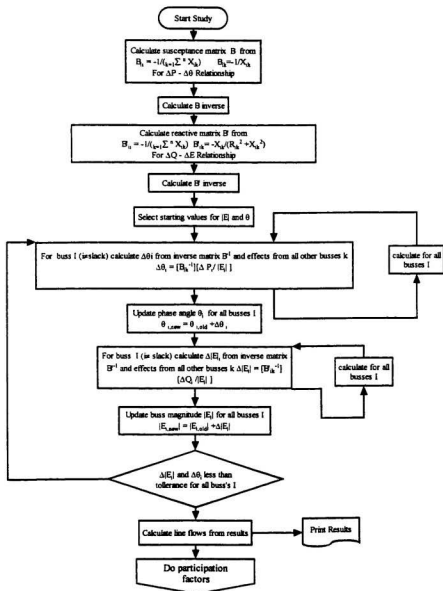

Figure 4.2 - De-coupled Load Flow Flow Chart

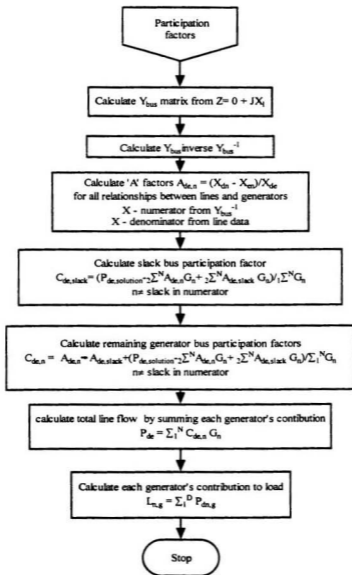

Figure 4.3 - Participation Factor Flow Chart

To determine the accuracy of the decomposition formulae the total of the contributions made by each generator to a particular line are checked against the total line current as determined by the load flow solution. Columns titled "difference" in section B of tables C.1 - C.5 numerate the accuracy.

A second check for accuracy is performed by computing the contributions in each line current made by each generator, to and from, a load bus. This is done to determine if the sum of the differences in line flows attributable to all generator equate to the same value as that of the installed load at the bus in question. Columns titled "difference" in sections C of tables C.1 - C.5 numerate the accuracy.

A third test for accuracy is performed by totaling the power contributed by each generator to each installed load to determine if a particular generator's total contribution to all the loads at the demand busses is equal to that of the same generators output as identified in the load flow solution. Rows titled "difference" in section C of tables C.1 - C.5 numerate this. The determination of accuracy via the second and third methods as mentioned above are calculable through a number of approaches. The possibility of different approaches exists as a result of there being two different current values presented for the same line in the load flow solution. For arbitrary busses A and B the solution will present a value of flow from A to B and a value for flow from B to A. The second is the negative to that specified from A to B and as well is of a slightly different value. These two differing values require a decision when implementing the formulae of the previous chapter, and as outlined in the above steps. This decision is required because the equation which dissects the total line current into components made by each generator contains a variable, C_{dir} , representing the value of current in the line in question resulting from a generator. Each of the two different values

for line current displayed in a load flow solution will produce slightly different results for a generator's participation factor in the total line current. In an effort to account for the discrepancy between the sending end and receiving end current values, and the problems they present when attempting summations at a load bus, it is possible to take three approaches

- 1) The average of the 2 line currents, forward and reverse, can be used to create an average value for the line participation factors for each generator. calculating 1 participation factor for the line in order to minimize the discrepancy between the sending and receiving voltages and creates one participation factor for the line - generator relationship.
- 2) The second method is to account for the differences in sending and receiving current values by creating a participation factor at the sending end of the line by using the value of sending current from the load flow solution. For those cases when a participation factor is required at a receiving end bus, the ratio of the reverse current to the forward current can be used to adjust the power entering the bus so that the summation can be calculated at the bus to determine the load drawn from the lines. The generators then maintain the same participation factor throughout the line.
- 3) Another approach is to permit two different participation factors to be calculated for each line - generator relationship, in association with each generator by using the forward current in one case and then the reverse current in the second case. This will create 2 different participation factors for each line and will slightly influence the magnitude of participation.

The reduction of discrepancies through one of the techniques was only applied to bus number 5 in case study 5, table C.5-C. to illustrate the ability to reduce and account for the disagreements present. This is discussed later in section 4.3.6, and figure 4.4.

4.3 TEST RESULTS

An analysis of the test results exhibit some interesting properties that are consistent with what is expected from the test system. Three points stand out. These are given as:

4.3.1 POINT ONE, RADIAL FEED

The first point deals with the flow on line numbers 14, 21 and 22. Line 14 connects bus 7

to bus 8 and is a radial feed. For all case studies the flow on this line is attributable only to generator 8. The decomposition results obtained confirm this within less than 1 percent error. Line 14 exists only to connect generator 8 to the main portion of the system and the value of flow on this line through the decomposition approach tracks the generation output of generator 8 as the output is changed in all the tests and is consistently attributed to generator 8. The results are shown in sections B of tables C.1-C.5. Similar analysis when applied to lines 21 and 22 indicate that the flow on these lines is attributable to only the generators to which they connect. These are the expected solutions.

4.3.2 POINT TWO, LOOP FEED

The second point, distinct and opposite from the first, deals with the flow on lines 1 and 2 which join busses 15 to 2 and busses 15 to 5 respectively. The total flow along lines 1 and 2, as identified in the load flow solution, are equivalent to that generated by generator 1 as it should be based on KCL. Rows 1 and 2 in section B of tables C.1 - C.5 illustrate this observation. Based on case study 1, generator 1's component of flow on transmission line number 1, as calculated through the use of participation factors, totals 102.5% of the resultant flow on line 1. Similarly, generator 1's component of flow on transmission line number 2 is 94.8% of the resultant flow on line 2. This analysis indicates that the output of generator 1 opposes the flow from the other generators on line 1 and reinforces the flow from the other generators on line 2. This is as expected, and is exactly the type of condition for which the decomposition formula is useful. Lines 1 and 2 create a loop feed in the system and will contain flow within themselves from generators 8 and 16 regardless as to whether or not generator 1 is on line and producing. Even though generator 1 is radially connected to these lines, the total use of these lines is not directly attributable to generator

1. This is an ideal example highlighting the decomposition of line flows into contributions made by each generator. The example also highlights one of the issues prevalent in transmission access costing and the developed method's usefulness for associating line costs.

4.3.3 POINT THREE, COUNTER FLOW

The third point deals with the flows attributable to generator 8 in transmission lines 4, 5, 6, and other lines as well, as illustrated in section B of tables C.1 - C.5. The current components attributable to generator 8 appear with an associated negative sign indicating that the flows from generator 8 run counter to the predominant flows of generators 1 and 16. This is verifiable through visual inspection of the system and is useful information for costing purposes as well.

4.3.4 TEST GROUP 1

It is evident from the results of the first group of tests, cases 1-3, table groupings C.1 - C.3, that in a system with isometric changes in load and generation, the system exhibits consistent participation factors for each generator - line relationship. For such an arrangement of scenarios of load sharing, the component of line current in each line contributed by a generator is predictable. This fact is illustrated in figures 4.5 - 4.7. This reaction to the system change as illustrated in the results, is as expected.

4.3.5 TEST GROUP 2

The second group of tests deals with a system with fixed values of generation at the non-swing busses which do not share in load following. The results in figures 4.8 - 4.10 and tables C.1, C.4 - C.5 in appendix C, indicate that the contribution of generation to line flows

are calculable. As well the generator - line participation factor combinations are only roughly predictable over large load changes. The worst example of this poor predictability is evident when comparing generator 8's contribution to the flow on transmission line 1 in studies 1 and 5. Generator 8's participation factor varies by 50% in these 2 cases. The entire load of the system differs by a multiple of 3 times in these 2 studies, and the change in generation required to meet the new load is completely serviced by the swing bus, generator 1, which is connected to transmission line 1. The lack of accurate predictability is expected due to the attempt to model a non linear system by way of a linear approach. This linear approach does not suitably account for the interactive component of line flows from generators. Although, the results over large load changes do offer some insight into the zone of influence of each generator on the power system and could possibly be used for small load changes, especially for transmission lines remote from the generator which is varying its contribution to the system. The comparison of other participation factors relating generator outputs and transmission line flows for the extreme differences in dispatch between case studies 1 and 5 generally differ by less than 10% for lines electrically remote from the direct influences of generators and can provide rough estimates in these cases. Figure 4.10 illustrates the participation factors over large load changes when no load sharing is established.

4.3.6 ACCURACY OF RESULTS

The results of the first group of tests, tests 1 - 3 , are summarized in figures 4.5 - 4.7 , and table groups C.1 - C.3, show that the contributions of each generator to the total flow in a transmission line are accurate as compared against the solutions in the load flow study. The magnitude of these errors and the associated percentages can be seen in columns titled

difference of section B of the tables and are satisfactory in the context of assumptions of constant line parameters, neglected line resistance and bus voltages approximating 1 p.u. Superior accuracy was expected here because the mathematical procedure does not actually estimate the total current in a transmission line by adding up each generator's contribution to the total. In reality the procedure works backward from the answer presented in the load flow solution. The method uses the transmission line currents that were solved for in the AC load flow solution, and then attributes specific percentages of each line current to each generator. When these percentages are recombined, the total will equal 100% once again. Even an erroneous decomposition, when recombined will produce a total equal to 100%. Such an erroneous decomposition can result from a poor inversion of the Y_{bus} matrix, or from false values within the original matrix. As a result any errors in decomposition are traceable only by examining the loads at the busses.

The second test for accuracy, outlined in columns titled "difference" in sections C of tables C.1 -C.5, indicates that each generator's contribution to the total load at a particular bus when added together are generally within 1. % of that of the installed load, which again is satisfactory. This can be improved if line losses are extracted from the results.

The only exceptions to this are numerated in rows 3, 5 and 7 in tables C.1-C to C.5-C. The calculated difference in these cases can be easily explained and reduced by using one of the 3 methods mentioned in section 4.2 of this chapter. The calculated difference in row 6 of table C.5-C, which is the largest disagreement in all the tables, and which deals with the load at bus 5, is calculated to be 18.42% when no attempt is made to reduce the discrepancies attributable to line losses. Through the use of method 2 in section 4.2 the calculated difference at bus 5 in study 5 can be reduced to less than 1%. The difference between

forward and reverse flows on lines joining busses 15-5, and 2-5, and the line losses that cause this difference, are the reasons for the discrepancies. The more appealing answer, and its effect on the total contribution from generators to loads, in case study 5 is shown below. However the adjustment of this calculated difference in no way effects the credibility of the formulae derived in the thesis. The justification for not using one of the three correction methods listed previously is the fact that the objective of the illustrations in sections "C" of the tables is to account for the total output of the generators. By comparing only the calculated loads at the busses to the outputs of the generators, the difference would contain two components. One of the components would be line losses and the other would be the errors resulting from the formulae. By not calculating line losses, the errors that result from the application of the formulae become more evident.

Bus num	Installed Load	g1 cont	g16 cont	g8 cont	Total cont	Difference	% dif
5	0.0228	0.01939121	0.00117272	0.00243607	0.023	0.0002	0.87719298
Calculated Total output		0.69562891	0.03981406	0.07005703	0.8055		
Actual Gen output		0.7	0.04	0.07			
difference		0.00437109	0.00018594	-5.7032E-06			
% difference		0.62444119	0.46485888	-0.08147413			

Figure 4.4 - Modified excerpt from table C.5-C, bus number 5.

The third test for accuracy, as given in rows titled difference in section C of tables C.1 - C.5 indicate that errors up to 1% are present. The total of the contributions for a particular generator to all of the installed loads are within acceptable error for estimating purposes. These error percentages can be reduced if line losses are more accurately accounted for. No attempt was made in this thesis to calculate the line losses attributable to each generator

as it is expected that given the generally small errors present, these copper losses are calculable. The simple implementation of $I^2 \cdot R$ can be applied easily as well.

**G1 LINE PARTICIPATION FACTORS FOR MULTIPLES OF
GENERATION AND LOAD**

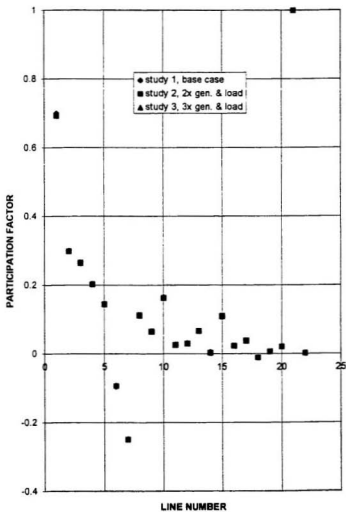

Figure 4.5 - G1 Participation Factors for Studies 1 -3

G16 LINE PARTICIPATION FACTORS FOR MULTIPLES OF GENERATION AND LOAD

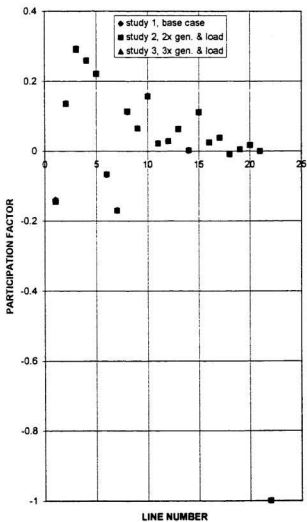

Figure 4.6 - G16 Line Participation Factors for Studies 1 - 3

**G8 LINE PARTICIPATION FACTORS FOR MULTIPLES OF
GENERATION AND LOAD**

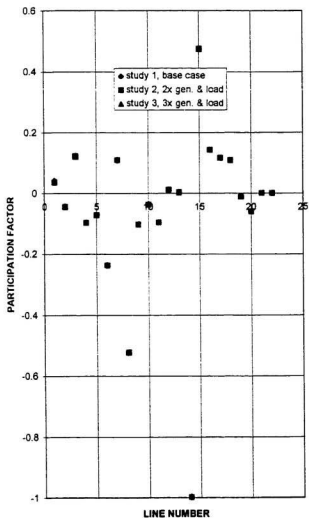

Figure 4.7 - G8 Line Participation Factors for Studies 1 -3

**G1 LINE PARTICIPATION FACTORS FOR FIXED GENERATION
AND MULTIPLES OF LOAD**

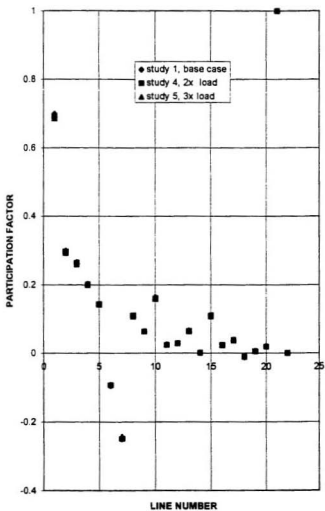

Figure 4.8 - G1 Line Participation Factors for Studies 1, 4 -5

**G16 LINE PARTICIPATION FACTORS FOR FIXED GENERATION
AND MULTIPLES OF LOAD**

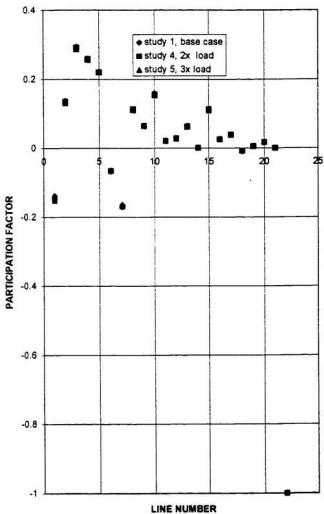

Figure 4.9 - G16 Line Participation Factors for Studies 1, 4 -5

**G8 LINE PARTICIPATION FACTORS FOR FIXED GENERATION
AND MULTIPLES OF LOAD**

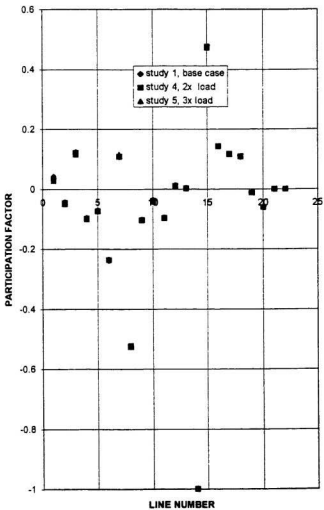

Figure 4.10 - G8 Line Participation Factors for Studies 1, 4 -5

CHAPTER 5

SUMMARY AND CONCLUSIONS

5.0 SUMMARY

Full retail and wholesale competition in the electric utility industry is a fait accompli. In the near future energy consumers will have a choice from whom to purchase their electric energy and some choice in the terms by which the energy is contracted. This introduction of consumer choice will initiate major changes in the corporate structure of electric utilities, the methods by which these companies are managed, the mechanisms by which revenues are generated and the manner by which the industry is regulated. The long standing industry structure comprised of regulated vertically integrated utilities which receive compensation based on verifiable and approved costs will be phased out. A more market based industry comprised of a regulated transmission sector which is independent of the less regulated generation and retail sectors, in a business dominated by a limited number of multinational utilities, formed through mergers and acquisitions, is highly probable.

A necessary mechanism for achieving this fundamental and significant change in the industry is the ability to have energy generators access their energy customers in a nondiscriminatory manner. This necessary link between sellers and buyers has been achieved in certain jurisdictions by legislating open access to the transmission systems of public utilities. Access to the transmission systems of private utilities will come about

through reciprocity provisions in the legislation. This open access to the transmission system will necessitate the filing of open access tariffs by transmission owning utilities, to each corporation's regulatory body, so that market participants will have some understanding of the resulting tariffs. It is expected that for the first few years after re-regulation wheeling rate design will be cost based as opposed to value based. The tariffs are necessary for obtaining the required revenues needed to pay for the capital and operating costs of the transmission infrastructure, and to finance any future reinforcements.

The terms by which cost based wheeling rates have historically been calculated are without complexity and will prove unsatisfactory in an era of open access. A pricing system reflecting the extent of use of the transmission system is a desirable component in future tolls. The customary costing methods used for compensation, such as the postage stamp method, and the contract path method, while simple to implement, oversimplify the physics of electric transmission and as a result do not adequately reflect the extent of use of the transmission infrastructure. The inability of these methods to account for loop flows is their major limitation. The federal Energy Regulatory Commission in the US has recognized this limitation and has commissioned studies into the issues of loop flows and has recommended the development of costing methodologies which more accurately reflect the extent of use of the system. The more credible costing methods being considered for evaluation to satisfy this request are based on some version of the Megawatt-Mile methodology. This methodology incorporates the amount of power being contracted and the transmission facilities used in the transaction. This measure of system use by a wheeling customer is then used in differing ways to apportion the costs of the existing system and upgrades between system users. The costs can be evaluated and allocated on an embedded,

marginal, or incremental basis, as discussed in chapter two.

The flow and distance sensitive compensation schemes being considered, regardless of version, all require some method for determining the path and magnitude of the transacted power between the generator and consumer so that the costing methodology can be employed. The application of participation factors to a load flow solution provide a mechanism for estimating the needed quantities and paths of transacted power.

The participation factors used in this thesis are obtained from the expression for generation shift factors and as a result are based on system configuration. Participation factors are created by generalizing the particular solution for these 'A' factors. 'A' factors provide a mechanism for estimating the change in flow on a transmission line that result from a change in output from a particular source. The generalization of this particular solution provides an expression that relates the absolute flow on a transmission line to the sum of components directly attributable to specific generators. This absolute relationship is obtained by shifting all the generation on the system to the swing bus, through the use of the 'A' factors, so as to obtain the needed quantities and constants for the particular system operating point in question. Each unique operating scenario requires the reformulation of new participation factors.

5.1 MAJOR CONTRIBUTION OF THIS WORK

The formulations developed in chapter 3, while modest, produce encouraging results, as a means for resolving the total flow on a transmission line into components attributable to the output of particular generators. While it is certain that the billing for wheeling services will be achieved through some form of revenue metering, the formulations derived within have value as a planning tool for estimating the usage of facilities by system users. The main

advantage of employing generalized participation factors is the ability to incorporate all the transactions that are present in a transmission system at a particular time into one study thereby increasing the speed with which different costing cases can be developed and analyzed. In comparison, through the method of successive studies, an equal plus one number of studies as that of generators need be conducted to determine the contributions made by each source to the total flow on each facility in the system. The method of isolating transactions also requires that an equal number plus one system studies to that of generators be completed to discern system flows between transmission customers. The implementation of this method is simple for any system and may be quite simple if the inverse Jacobian matrix is extractable from the system software used for calculating load flow solutions. The method requires that one system load flow study be conducted from which the calculation and application of the generalized participation factors is then carried out. The formulation can easily be incorporated into system planning software as a utility.

5.2 CONCLUSIONS

The need for an efficient methodology which resolves the power flow on transmission lines into components attributable to specific generators is a requirement when developing and implementing acceptable open access tariffs. While it may be years before suitable tariffs are widely accepted by regulatory bodies and eventually implemented, the method outlined in this thesis shows encouraging results as a method for estimating such resolution of flows. A sample IEEE 14 bus system has been successfully implemented. It provides confirmatory tests of the novel cost allocation methods outlined in this thesis.

5.3 RECOMMENDATIONS FOR FUTURE WORKS

Firstly, the formulae in this work were developed for application to simple transmission systems which do not include phase shifting transformers. Modifications to include the

effects of these devices would add to the usefulness of the devised method. Secondly, the relationship between line currents and generator injections can be investigated through the application of line outage factors. Thirdly, this thesis deals mainly with the costs associated with real power flow in a transmission system. For a complete analysis of tariff costs, consideration and research will have to be given to the costs of production associated with transmission. Fourthly, it may be desirable to analyze the costs of electricity transport from the perspective of the receiving load busses as opposed to the generation busses, as earlier alluded to. Finally, the costs associated with the use of the distribution systems will require further research.

BIBLIOGRAPHY

- 1 Federal Energy Regulatory Commission order No. 888, "Promoting Wholesale Competition Through Open Access Non-discriminatory Transmission Services By Public Utilities", Final Rule, April 24, 1996.
- 2 Happ, H. H., "Transmission Access Issues", IEEE Trans. on Power Systems, Vol. 11, No. 1, Feb. 1996. Pages 41- 51.
- 3 Federal Energy Regulatory Commission order No. 889, "Open Access Same Time Information System and Standards of Conduct", Final Rule, April 24, 1996.
- 4 Sheble, G. B. "Priced Based Operation in an Auction Markets Structure", IEEE Trans. on Power Systems, Vol. 11, No. 4, Nov. 1996. Pages 1770 - 1777.
- 5 Sheble, G., "The Implementation of an Energy Brokerage System using Linear Programming", IEEE Trans. On Power Systems, Vol. 7, No. 1, Feb. 1992. Pages 90 - 96.
- 6 Gedra, T., "Markets and Pricing for Interruptible Electric Power", IEEE Trans. On Power Systems, Vol. 8, No. 4, Feb 1993. Pages 122 - 128.
- 7 Sheble, G., "Applications of Auctions as A Pricing Mechanism For The Interchange of Electric Power", IEEE Trans. On Power Systems, Vol. 10, No 3, Aug 1995. Pages 1580 - 1584.
- 8 Gedra, T. W., "Optional Forward Contracts for Electric Power Markets", IEEE Trans. on Power Systems., Vol. 9, No. 4, Nov. 1994. Pages 1766-1773.
- 9 Shirmohammadi, D., "Cost of Transmission Transactions: An Introduction", IEEE Trans. on Power Systems, Vol. 6, No 4, Nov. 1991. Pages 1546 - 1560.

- 10 Shirmohammadi, D. et al. "Evaluation of network capacity use for wheeling transactions", IEEE Transactions on Power Systems, Oct 1989, vol. 4, No. 4, pages 1405-1413.
- 11 Happ, H.H., " Cost of Wheeling Methodologies", IEEE Trans. on Power Systems Vol. 9. No. 1, Feb. 1994. Pages 147 - 156.
- 12 Shirmohammadi, D., Pereira, M, P., "Some Fundamental Technical Concepts About Cost Based Transmission Pricing", IEEE Trans. on Power Systems, Vol. 11, No. 2, May 1996, Pages 1002 - 1008.
- 13 Kovacs, R. R., " A Load Flow Based Method for Calculating Embedded, Incremental and Marginal cost of Transmission Capacity", IEEE Transactions on Power Systems, Vol. 9, No. 1, Feb 1994, Pages 272 - 278.
- 14 Marangon, J. W., "Allocation of Transmission Fixed Charges: An Overview", IEEE Trans. On Power Systems, Vol. 11, No. 3, Aug. 1996. Pages 1409 - 1418.
- 15 Perez-Arriaga, I., "International Power System Transmission Open Access Experience", IEEE Trans. on Power Systems. Vol. 10, No. 1, Feb. 1995. Pages 553 - 564.
- 16 Zobian, A., "Unbundling of Transmission and Ancillary Services, Part II: Cost Based Pricing Framework", IEEE Trans. on Power Systems, Vol. 12, Num. 2, May 1997. Pages 549 - 558.
- 17 Happ, H. H., Selection of methods for evaluating the cost of transmission wheeling services. Proceedings of the 57th annual American Power Conference. 1995, pages 606 - 611
- 18 Kavicky, J.-A., et al., "Parallel Aspects of Transmission Modeling" , IEEE Trans. on Power Systems, Vol. 11, No. 3, Aug 1996. Pages 1180 - 1189.
- 19 Wijayatunga . P.D., "Probabilistic Costing of Transmission Services" Ph. D. Thesis, Imperial College, London, 1992
- 20 Lo, K. L. et al., "Wheeling and Marginal Wheeling Rates: Theory and Case Study results". Electric Power Systems Research, 27 (1993), Pages 11 - 26.
- 21 Perez-Arriaga , I. J., "Marginal Pricing of Transmission Services: An Analysis of Cost Recovery", IEEE Transactions on Power Systems, Vol 10, No. 1, Feb. 1995, pages 546-553.
- 22 El-Keib, A. A., et al., "Calculating Short Run Marginal Costs of Active and Reactive Power Production., IEEE Transactions on Power Systems, Vol. 12, No 2, May 1997. Pages 559 - 565.

- 23 Stevenson, W. D., "Elements Of Power System Analysis", 4th edition, 1982, McGraw- Hill.
- 24 Heydt. G. T., "Compuer Analysis Methods For Power Systems", 1986, Macmillian.
- 25 Stott, B., "Fast Decoupled Load Flow", IEEE Trans. on PAS, Vol. PAS-93, May/June 1974. Pages 859 - 869.
- 26 Ng, W., "Generalized Generation Distribution Factors for Power System Security Evaluation". IEEE Trans. on PAS. Vol. PAS-100, No. 3, March 1981. Pages 1001 - 1005.
- 27 El-Hawary, M. "Optimal Operation Of Electrical Power Systems". 1979, Academic Press.
- 28 Chang, Y. C., et al., "A New Method For Calculating Loss Coefficients", IEEE Trans. on Power Systems, Vol. 9, No. 3, Aug .1994. Pages 1665 - 1671.
- 29 Rudnick, H., et al., "Marginal Pricing and Supplement Cost Allocation In Transmission Open Access". IEEE Trans. on Power Systems, Vol. 10, No. 2, May 1995, Pages 1125 - 1142.
- 30 Lu Q. C., et al., "Transmission Loss Penalty Factors for Area Interchange", IEEE Trans. on Power Systems, Vol. 11, No. 3, Aug. 1996, Pages 1387 - 1392.
- 31 Irving, M. R. , " An Algorithm for The Allocation of Distribution System Demand and Energy Losses", IEEE Trans. on Power Systems, Vol. 11, No. 1, 1996. Pages 338 - 343.
- 32 Ilic, M. D. et al, " Available Transmission Capacity (ATC) and its Value Under Open Access". IEEE Trans. on Power Systems Vol. 12, No. 2, May 1997, Pages 636 - 645.
- 33 Vaahedi E., "Benefits of Economy Transactions and Wheeling in Canada", IEEE Trans. on Power Systems, Vol. 8, No. 3, Aug, 1993. Pages 1299 - 1306
- 34 Jacobs, J., "Artificial Power Markets And Unintended Consequences", IEEE Trans. on Power Systems, Vol. 12, No. 2, May 1997. Pages 968 - 972.
- 35 Zobian, A., "Unbundling of Transmission and Ancillary Services, Part 1: Technical Issues", IEEE Trans. on Power Systems, Vol. 12, No. 2, May 1997. Pages 539 - 548

- 36 B.C Hydro and Power Authority, "B.C. Hydro, Whole Sale Transmission Application: Decision", June 25 1996.
- 37 Trim D.W., "Calculus and Analytic Geometry", 1983, Addison-Wesley.
- 38 Rudnick, H., "Economically Adapted Transmission Systems in Open Access Schemes - Application of Genetic Algorithms", IEEE Trans. on Power Systems, Vol. 11, No. 3, pages 1427- 1440, Aug., 1996.
- 39 Ray, D, J. "A Cost Analysis of Wheeling in the Electric Utility Industry", Ph.D. thesis, University of Wisconsin - Madison. 1987
- 40 Alvarado, F.L., "Penalty Factors From Newton's Method", IEEE Transactions on Power Systems, vol. PAS-97, No. 6, Nov/Dec 1976.
- 41 Kirchmayer, L. K. "Economic Operation Of Power Systems". Wiley, 1958.
- 42 Schweppe , F. C., et al, " WRATES: A Tool for Evaluating The Marginal Cost of Wheeling, IEEE Transactions on Power Systems, Vol. 4, No. 2, May 1989, pages 594 - 605.
- 43 Sheble, G., " Framework For Energy Brokerage System With Reserve Margin and Transmission Losses", IEEE Trans. On Power Systems, Vol. 11, No. 4, 1996. Pages 1763 - 1769.
- 44 Wakefield, R. A., et al., " A Transmission Service Costing Framework", IEEE Trans. on Power Systems, Vol. 12, No. 2, May 1997. Pages 622 - 628.
- 45 Ancona, J. J., et al. "A bid Solicitation Method for Developing a Competitive Spot Priced Electric Market" , IEEE Transactions on Power Systems, Vol. 12, No. 2, May 1997. Pages 743 - 748.
- 46 Glover, J.D., Sarma, Digby, G., "Power System Analysis and Design With Personal computer Applications", PWS Publishers, Boston, 1987.
- 47 Kovacs, R, et al, "Transmission Access and Pricing with Multiple Separate Energy Forward Markets", Recommended and approved for publication in the IEEE Transactions on Power Systems, submitted July 21, 1997.

APPENDIX A

IEEE 14 BUS SYSTEM AND SYSTEM DATA

TABLE A.1 - MODIFIED IEEE 14 BUS SYSTEM, BUS DATA

BUS NUMBER	STARTING BUS VOLTAGES		GENERATION		LOAD	
	MAGNITUDE	ANGLE	MW	MVAR LIMIT	MW	MVAR
1	1.005	0			0	0
2	1	0	0	0	0.0217	0.127
3	1	0	0	0	0.0942	0.019
4	1	0	0	0	0.0478	-0.0039
5	1	0	0	0	0.0076	0.0016
6	1	0	0	0	0.0112	0.0075
7	1	0	0	0	0	0
8	1	0	0.07	+/- 0.05	0	0
9	1	0	0	0	0.0295	0.0166
10	1	0	0	0	0.009	0.0058
11	1	0	0	0	0.0035	0.0018
12	1	0	0	0	0.0061	0.0016
13	1	0	0	0	0.0135	0.0058
14	1	0	0	0	0.0149	0.005
15	1	0	0	0	0	0
16	1	0	0.04	+/- 0.03	0	0

BASE = 100MVA

TABLE A.2 - MODIFIED IEEE 14 BUS SYSTEM, LINE DATA

LINE NUMBER	LINE DESIGNATION	RESISTANCE	IND. REAC.	CAPACITANCE
1	L 1-2	0.01938	0.05917	0.0528
2	L 1-5	0.05403	0.22304	0.0492
3	L 2-3	0.04699	0.19797	0.0438
4	L 2-4	0.05811	0.17632	0.0374
5	L 2-5	0.05695	0.17388	0.034
6	L 3-4	0.06701	0.17103	0.0346
7	L 4-5	0.01335	0.04211	0.0128
8	L 4-7	0.0001	0.20912	
9	L 4-9	0.15	0.55618	
10	L 5-6	0.07	0.25202	
11	L 6-11	0.09498	0.1989	
12	L 6-12	0.12291	0.25581	
13	L 6-13	0.06615	0.13027	
14	L 7-8	0.05	0.17615	
15	L 7-9	0.03	0.11001	
16	L 9-10	0.03181	0.0845	
17	L 9-14	0.12711	0.27038	
18	L 10-11	0.08205	0.19207	
19	L 12-13	0.22092	0.19988	
20	L 13-14	0.17093	0.34802	
21	L 1 - 15	0.03	0.1	
22	L 2 - 16	0.03	0.1	

BASE = 100 MVA

MODIFIED IEEE 14 BUS SYSTEM, SINGLE LINE DIAGRAM

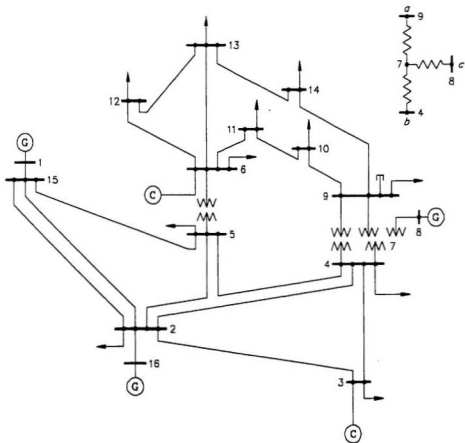

FIGURE A.1 MODIFIED IEEE 14 BUS SYSTEM

APPENDIX B

TABLE OF CONTENTS

CASE STUDY 1 - BASE CASE	B - 1
CASE STUDY 2 - DOUBLE LOAD WITH LOAD SHARING	B - 9
CASE STUDY 3 - TRIPLE LOAD WITH LOAD SHARING	B - 17
CASE STUDY 4 - DOUBLE LOAD, ADDITIONAL LOAD SERVICED BY SLACK BUS	B - 24
CASE STUDY 5 - TRIPLE LOAD, ADDITIONAL LOAD SERVICED BY SLACK BUS	B - 32

RAW DATA AND LOAD FLOW SOLUTIONS

CASE STUDY 1 - BASE CASE

22
 THE NUMBER OF LINES IS : 22

1	15	2	.01938	.05917	0	0	5
2	15	5	.05403	.22304	0	0	5
3	2	3	.04699	.19797	0	0	5
4	2	4	.05811	.17632	0	0	5
5	2	5	.05695	.17388	0	0	5
6	3	4	.06701	.17103	0	0	5
7	4	5	.01335	.04211	0	0	5
8	4	7	.0001	.20912	0	0	5
9	4	9	.15	.55618	0	0	5
10	5	6	.07	.25202	0	0	5
11	6	11	.09498	.1989	0	0	5
12	6	12	.12291	.25581	0	0	5
13	6	13	.06615	.13027	0	0	5
14	7	8	.05	.17615	0	0	5
15	7	9	.03	.11001	0	0	5
16	9	10	.03181	.0845	0	0	5
17	9	14	.12711	.27038	0	0	5
18	10	11	.08205	.19207	0	0	5
19	12	13	.22092	.19988	0	0	5
20	13	14	.17093	.34802	0	0	5
21	1	15	.03	.1	0	0	5
22	2	16	.03	.1	0	0	5

THE LARGEST BUS NUMBER IS 16

1	0	1.005	0	0	0	0	0
2	1	1	0	0	.0217	.0127	0
3	1	1	0	0	.0942	.019	0
4	1	1	0	0	.0478	-.0039	0
5	1	1	0	0	.0076	.0016	0
6	1	1	0	0	.0112	.0075	0
7	1	1	0	0	0	0	0
8	2	1	0	.07	0	.05	-.05
9	1	1	0	0	.0295	.0166	0
10	1	1	0	0	.009	.0058	0
11	1	1	0	0	.0035	.0018	0
12	1	1	0	0	.0061	.0016	0
13	1	1	0	0	.0135	.0058	0
14	1	1	0	0	.0149	.005	0
15	1	1	0	0	0	0	0
16	2	1	0	.04	0	.03	-.03

WARNING: YOUR TRANSFORMER DATA IS EMPTY.
 PLEASE CHECK YOUR TRANSFORMER INPUT DATA.
 PRESS RETURN TO CONTINUE.
 THE NUMBER OF TRANSFORMERS IS 0

THE TOLERANCE LEVEL IS .0001 .

DO YOU WANT TO CHANGE THE TOLERANCE LEVEL (Y OR N)? nn

THE MAXIMUM NUMBER OF ITERATIONS IS 20 .

DO YOU WANT TO CHANGE THE NUMBER OF ITERATIONS (Y OR N)? nn
 SELECTION OF INITIAL BUS VOLTAGE MAGNITUDES AND ANGLES :

1. FLAT START
2. OUTPUT VALUES FROM THE PREVIOUS RUN

ENTER YOUR SELECTION (1 OR 2) 11

STARTING VALUES

1.005 0
 1.005 0
 1.005 0
 1.005 0
 1.005 0
 1.005 0
 1.005 0
 1 0
 1.005 0
 1.005 0
 1.005 0
 1.005 0
 1.005 0
 1.005 0
 1.005 0
 1 0

****THE PROGRAM IS RUNNING****

BUS ADMITTANCES MATRIX, REAL PARTS

```

-----
 2.752   0.000   0.000   0.000   0.000   0.000   0.000   0.000
 0.000   0.000   0.000   0.000   0.000   0.000  -2.752   0.000
 0.000  12.274  -1.135  -1.686  -1.701   0.000   0.000   0.000
 0.000   0.000   0.000   0.000   0.000   0.000  -4.999  -2.752
 0.000  -1.135   3.121  -1.986   0.000   0.000   0.000   0.000
 0.000   0.000   0.000   0.000   0.000   0.000   0.000   0.000
 0.000  -1.686  -1.986  10.967  -6.841   0.000  -2.002   0.000
-0.452   0.000   0.000   0.000   0.000   0.000   0.000   0.000
 0.000  -1.701   0.000  -6.841  10.591  -1.023   0.000   0.000
 0.000   0.000   0.000   0.000   0.000   0.000  -1.026   0.000
 0.000   0.000   0.000   0.000  -1.023   7.603   0.000   0.000
 0.000   0.000  -1.955  -1.526  -3.099   0.000   0.000   0.000
 0.000   0.000   0.000  -0.002   0.000   0.000   3.801  -1.491
-2.307   0.000   0.000   0.000   0.000   0.000   0.000   0.000
 0.000   0.000   0.000   0.000   0.000   0.000  -1.491   1.491
 0.000   0.000   0.000   0.000   0.000   0.000   0.000   0.000
 0.000   0.000   0.000  -0.452   0.000   0.000  -2.307   0.000
 8.085  -3.902   0.000   0.000   0.000  -1.424   0.000   0.000
  
```

-14.768	4.403	0.000	0.000	0.000	0.000	0.000	0.000	0.000	0.000
0.000	0.000	0.000	0.000	0.000	4.094	0.000	0.000	0.000	0.000
4.403	-8.497	0.000	0.000	0.000	0.000	0.000	0.000	0.000	0.000
0.000	0.000	0.000	0.000	0.000	0.000	3.176	0.000	0.000	0.000
0.000	0.000	-5.428	2.252	0.000	0.000	0.000	0.000	0.000	0.000
0.000	0.000	0.000	0.000	0.000	0.000	6.103	0.000	0.000	0.000
0.000	0.000	2.252	-10.670	2.315	0.000	0.000	0.000	0.000	0.000
0.000	0.000	0.000	0.000	0.000	0.000	0.000	0.000	0.000	3.029
0.000	0.000	0.000	2.315	-5.344	0.000	0.000	0.000	0.000	0.000
9.174	15.263	0.000	0.000	4.235	0.000	0.000	0.000	0.000	0.000
0.000	0.000	0.000	0.000	0.000	-28.672	0.000	0.000	0.000	0.000
0.000	9.174	0.000	0.000	0.000	0.000	0.000	0.000	0.000	0.000
0.000	0.000	0.000	0.000	0.000	0.000	0.000	0.000	0.000	-9.174

***** PLEASE WAIT PROGRAM IS RUNNING *****

ITERATION # 1

***** PLEASE WAIT .. PROGRAM IS RUNNING *****
 THE NUMBER OF ROWS IN THE JACOBIAN MATRIX = 28

ITERATION # 1

MISMATCH = 5.29E-01

ITERATION # 2

***** PLEASE WAIT .. PROGRAM IS RUNNING *****
 THE NUMBER OF ROWS IN THE JACOBIAN MATRIX = 28

ENTER YOUR SELECTION (1,2,3 OR 4) 33

DO YOU WANT TO DISPLAY THE BUS OUTPUT DATA (Y OR N) ? yy

DO YOU WANT TO DISPLAY THE LINE OUTPUT DATA (Y OR N) ? yy

DO YOU WANT TO DISPLAY THE TRANSFORMER OUTPUT DATA (Y OR N) ? nn

DO YOU WANT TO DISPLAY THE OUTPUT DATA IN EXPONENTIAL FORMAT (Y OR N) ? yy
USE THE Ctrl PRINT SCREEN OPTION NOW IF YOU WANT TO PRINT THE RESULTS.
PRESS RETURN TO CONTINUE.

POWER FLOW BUS OUTPUT DATA FOR

BUS#	VOLTAGE MAGNITUDE	PHASE ANGLE	GENERATION		LOAD	
			PG	QG	PL	QL .95>V>1.05
	per unit	degrees	per unit	per unit	per unit	per unit
1	1.01E+00	0.00E+00	1.51E-01	2.64E-02	0.00E+00	0.00E+00
2	9.95E-01	-1.16E+00	0.00E+00	0.00E+00	2.17E-02	1.27E-02
3	9.89E-01	-1.81E+00	0.00E+00	0.00E+00	9.42E-02	1.90E-02
4	9.92E-01	-1.49E+00	0.00E+00	0.00E+00	4.78E-02	-3.90E-03
5	9.93E-01	-1.40E+00	0.00E+00	0.00E+00	7.60E-03	1.60E-03
6	9.87E-01	-1.75E+00	0.00E+00	0.00E+00	1.12E-02	7.50E-03
7	9.92E-01	-1.30E+00	0.00E+00	0.00E+00	0.00E+00	0.00E+00
8	1.00E+00	-6.54E-01	7.00E-02	2.41E-02	0.00E+00	0.00E+00
9	9.88E-01	-1.61E+00	0.00E+00	0.00E+00	2.95E-02	1.66E-02
10	9.87E-01	-1.66E+00	0.00E+00	0.00E+00	9.00E-03	5.80E-03
11	9.87E-01	-1.72E+00	0.00E+00	0.00E+00	3.50E-03	1.80E-03
12	9.85E-01	-1.83E+00	0.00E+00	0.00E+00	6.10E-03	1.60E-03
13	9.85E-01	-1.83E+00	0.00E+00	0.00E+00	1.35E-02	5.80E-03
14	9.85E-01	-1.81E+00	0.00E+00	0.00E+00	1.49E-02	5.00E-03
15	9.98E-01	-8.18E-01	0.00E+00	0.00E+00	0.00E+00	0.00E+00
16	9.99E-01	-9.77E-01	4.00E-02	3.00E-02	0.00E+00	0.00E+00
TOTAL			2.61E-01	8.05E-02	2.59E-01	7.35E-02

MISMATCH = 2.30E-05

POWER FLOW LINE OUTPUT DATA FOR

LINE #	BUS TO BUS	P	Q	S	RATING EXCEEDED
1	15 2	1.03E-01	1.19E-02	1.03E-01	

	2	15	-1.03E-01	-1.13E-02	1.03E-01
2	15	5	4.77E-02	1.22E-02	4.92E-02
	5	15	-4.75E-02	-1.16E-02	4.89E-02
3	2	3	6.06E-02	1.61E-02	6.27E-02
	3	2	-6.04E-02	-1.53E-02	6.23E-02
4	2	4	3.43E-02	5.99E-03	3.48E-02
	4	2	-3.43E-02	-5.77E-03	3.47E-02
5	2	5	2.58E-02	6.26E-03	2.66E-02
	5	2	-2.58E-02	-6.14E-03	2.65E-02
6	3	4	-3.38E-02	-3.70E-03	3.40E-02
	4	3	3.39E-02	3.91E-03	3.41E-02
7	4	5	-3.71E-02	3.66E-04	3.71E-02
	5	4	3.71E-02	-3.07E-04	3.71E-02
8	4	7	-1.56E-02	-4.00E-04	1.56E-02
	7	4	1.56E-02	4.51E-04	1.56E-02
9	4	9	5.23E-03	5.81E-03	7.82E-03
	9	4	-5.22E-03	-5.77E-03	7.78E-03
10	5	6	2.86E-02	1.65E-02	3.30E-02
	6	5	-2.85E-02	-1.62E-02	3.28E-02
11	6	11	-1.91E-03	9.41E-04	2.13E-03
	11	6	1.91E-03	-9.40E-04	2.13E-03
12	6	12	6.44E-03	2.24E-03	6.82E-03
	12	6	-6.43E-03	-2.23E-03	6.81E-03
13	6	13	1.28E-02	5.51E-03	1.39E-02
	13	6	-1.28E-02	-5.48E-03	1.39E-02
14	7	8	-6.97E-02	-2.31E-02	7.35E-02
	8	7	7.00E-02	2.41E-02	7.40E-02
15	7	9	5.42E-02	2.27E-02	5.87E-02
	9	7	-5.41E-02	-2.23E-02	5.85E-02
16	9	10	1.44E-02	6.69E-03	1.59E-02
	10	9	-1.44E-02	-6.67E-03	1.59E-02
17	9	14	1.53E-02	4.76E-03	1.61E-02
	14	9	-1.53E-02	-4.69E-03	1.60E-02
18	10	11	5.41E-03	8.66E-04	5.48E-03
	11	10	-5.41E-03	-8.60E-04	5.48E-03
19	12	13	3.32E-04	6.27E-04	7.09E-04
	13	12	-3.32E-04	-6.27E-04	7.09E-04
20	13	14	-4.12E-04	3.12E-04	5.17E-04
	14	13	4.12E-04	-3.12E-04	5.17E-04
21	1	15	1.51E-01	2.64E-02	1.53E-01

	15	1	-1.50E-01	-2.41E-02	1.52E-01
22	2	16	-3.99E-02	-2.98E-02	4.98E-02
	16	2	4.00E-02	3.00E-02	5.00E-02

REMOVE Ctrl PRINT SCREEN AND THEN PRESS RETURN TO CONTINUE.

CASE STUDY 2 - DOUBLE LOAD WITH LOAD SHARING

22
 THE NUMBER OF LINES IS : 22
 1 15 2 .01938 .05917 0 0 5
 2 15 5 .05403 .22304 0 0 5
 3 2 3 .04699 .19797 0 0 5
 4 2 4 .05811 .17632 0 0 5
 5 2 5 .05695 .17388 0 0 5
 6 3 4 .06701 .17103 0 0 5
 7 4 5 .01135 .04211 0 0 5
 8 4 7 .0001 .20912 0 0 5
 9 4 9 .15 .55618 0 0 5
 10 5 6 .07 .25202 0 0 5
 11 6 11 .09498 .1989 0 0 5
 12 6 12 .12291 .25581 0 0 5
 13 6 13 .06615 .13027 0 0 5
 14 7 8 .05 .17615 0 0 5
 15 7 9 .03 .11001 0 0 5
 16 9 10 .03181 .0845 0 0 5
 17 9 14 .12711 .27038 0 0 5
 18 10 11 .08205 .19207 0 0 5
 19 12 13 .22092 .19988 0 0 5
 20 13 14 .17093 .34802 0 0 5
 21 1 15 .03 .1 0 0 5
 22 2 16 .03 .1 0 0 5

THE LARGEST BUS NUMBER IS 16
 1 0 1.005 0 0 0 0 0 0 0
 2 1 1 0 0 0 .0434 .0254 0 0 0
 3 1 1 0 0 0 .1884 .038 0 0 0
 4 1 1 0 0 0 .0956 -.0078 0 0 0
 5 1 1 0 0 0 .0152 .0032 0 0 0
 6 1 1 0 0 0 .0224 .015 0 0 0
 7 1 1 0 0 0 0 0 0 0
 8 2 1 0 .14 0 0 0 .1 -1
 9 1 1 0 0 .059 .0332 0 0
 10 1 1 0 0 0 .018 .0116 0 0
 11 1 1 0 0 0 .007 .0036 0 0
 12 1 1 0 0 0 .0122 .0032 0 0
 13 1 1 0 0 0 .027 .0116 0 0
 14 1 1 0 0 0 .0298 .01 0 0
 15 1 1 0 0 0 0 0 0 0
 16 2 1 0 .08 0 0 0 .06 -.06

WARNING: YOUR TRANSFORMER DATA IS EMPTY.
 PLEASE CHECK YOUR TRANSFORMER INPUT DATA.
 PRESS RETURN TO CONTINUE.
 THE NUMBER OF TRANSFORMERS IS 0

THE TOLERANCE LEVEL IS .0001 .

DO YOU WANT TO CHANGE THE TOLERANCE LEVEL (Y OR N)? NN

THE MAXIMUM NUMBER OF ITERATIONS IS 20 .

DO YOU WANT TO CHANGE THE NUMBER OF ITERATIONS (Y OR N)? NN
 SELECTION OF INITIAL BUS VOLTAGE MAGNITUDES AND ANGLES :

1. FLAT START
2. OUTPUT VALUES FROM THE PREVIOUS RUN

ENTER YOUR SELECTION (1 OR 2) 11

STARTING VALUES

1.005 0
 1.005 0
 1.005 0
 1.005 0
 1.005 0
 1.005 0
 1.005 0
 1.005 0
 1 0
 1.005 0
 1.005 0
 1.005 0
 1.005 0
 1.005 0
 1.005 0
 1.005 0
 1 0

****THE PROGRAM IS RUNNING****

BUS ADMITTANCES MATRIX, REAL PARTS

```

-----
 2.752   0.000   0.000   0.000   0.000   0.000   0.000   0.000
 0.000   0.000   0.000   0.000   0.000   0.000  -2.752   0.000
 0.000  12.274  -1.135  -1.686  -1.701   0.000   0.000   0.000
 0.000   0.000   0.000   0.000   0.000   0.000  -4.999  -2.752
 0.000  -1.135   3.121  -1.986   0.000   0.000   0.000   0.000
 0.000   0.000   0.000   0.000   0.000   0.000   0.000   0.000
 0.000  -1.686  -1.986  10.967  -6.841   0.000  -0.002   0.000
-0.452   0.000   0.000   0.000   0.000   0.000   0.000   0.000
 0.000  -1.701   0.000  -6.841  10.591  -1.023   0.000   0.000
 0.000   0.000   0.000   0.000   0.000   0.000  -1.026   0.000
 0.000   0.000   0.000   0.000  -1.023   7.603   0.000   0.000
 0.000   0.000  -1.955  -1.526  -3.099   0.000   0.000   0.000
 0.000   0.000   0.000  -0.002   0.000   0.000   3.801  -1.491
-2.307   0.000   0.000   0.000   0.000   0.000   0.000   0.000
 0.000   0.000   0.000   0.000   0.000   0.000  -1.491   1.491
 0.000   0.000   0.000   0.000   0.000   0.000   0.000   0.000
 0.000   0.000   0.000  -0.452   0.000   0.000  -2.307   0.000
 8.085  -3.902   0.000   0.000   0.000  -1.424   0.000   0.000
  
```

-14.768	4.403	0.000	0.000	0.000	0.000	0.000	0.000	0.000	0.000
0.000	0.000	0.000	0.000	0.000	4.094	0.000	0.000	0.000	0.000
4.403	-8.497	0.000	0.000	0.000	0.000	0.000	0.000	0.000	0.000
0.000	0.000	0.000	0.000	0.000	0.000	3.176	0.000	0.000	0.000
0.000	0.000	-5.428	2.252	0.000	0.000	0.000	0.000	0.000	0.000
0.000	0.000	0.000	0.000	0.000	0.000	6.103	0.000	0.000	0.000
0.000	0.000	2.252	-10.670	2.315	0.000	0.000	0.000	0.000	0.000
0.000	0.000	0.000	0.000	0.000	0.000	0.000	0.000	0.000	3.029
0.000	0.000	0.000	2.315	-5.344	0.000	0.000	0.000	0.000	0.000
9.174	15.263	0.000	0.000	4.235	0.000	0.000	0.000	0.000	0.000
0.000	0.000	0.000	0.000	0.000	0.000	-28.672	0.000	0.000	0.000
0.000	9.174	0.000	0.000	0.000	0.000	0.000	0.000	0.000	0.000
0.000	0.000	0.000	0.000	0.000	0.000	0.000	-9.174	0.000	0.000

***** PLEASE WAIT ... PROGRAM IS RUNNING *****

ITERATION # 1

***** PLEASE WAIT .. PROGRAM IS RUNNING *****
 THE NUMBER OF ROWS IN THE JACOBIAN MATRIX = 28

ITERATION # 1
 MISMATCH = 9.42E-01

ITERATION # 2

***** PLEASE WAIT .. PROGRAM IS RUNNING *****
 THE NUMBER OF ROWS IN THE JACOBIAN MATRIX = 28

ITERATION # 6
 MISMATCH = 2.15E-05
 QG 8 = 6.351948E-02
 TOTAL NUMBER OF ITERATIONS = 6
 MISMATCH = 2.15E-05
 PRESS RETURN TO CONTINUE

THE RESULTS ARE NOW BEING SENT TO OUTPUT DATA FILES.

WOULD YOU LIKE TO:
 1. UPDATE THE INPUT DATA FILES
 2. RUN THE PROGRAM
 3. DISPLAY THE OUTPUT DATA
 4. STOP

ENTER YOUR SELECTION (1,2,3 OR 4) 33

DO YOU WANT TO DISPLAY THE BUS OUTPUT DATA (Y OR N) ? YY

DO YOU WANT TO DISPLAY THE LINE OUTPUT DATA (Y OR N) ? YY

DO YOU WANT TO DISPLAY THE TRANSFORMER OUTPUT DATA (Y OR N) ? NN

DO YOU WANT TO DISPLAY THE OUTPUT DATA IN EXPONENTIAL FORMAT (Y OR N) ? YY
 USE THE Cc1 PRINT SCREEN OPTION NOW IF YOU WANT TO PRINT THE RESULTS.
 PRESS RETURN TO CONTINUE.

POWER FLOW BUS OUTPUT DATA FOR

BUS#	VOLTAGE MAGNITUDE	PHASE ANGLE	GENERATION		LOAD	
			PG	QG	PL	QL .95>V>1.01
	per unit	degrees	per unit	per unit	per unit	per unit
1	1.01E+00	0.00E+00	3.07E-01	5.24E-02	0.00E+00	0.00E+00
2	9.86E-01	-2.37E+00	0.00E+00	0.00E+00	4.34E-02	2.54E-02
3	9.74E-01	-3.72E+00	0.00E+00	0.00E+00	1.88E-01	3.80E-02
4	9.80E-01	-3.06E+00	0.00E+00	0.00E+00	9.56E-02	-7.80E-03
5	9.81E-01	-2.87E+00	0.00E+00	0.00E+00	1.52E-02	3.20E-03
6	9.69E-01	-3.60E+00	0.00E+00	0.00E+00	2.24E-02	1.50E-02

7	9.82E-01	-2.69E+00	0.00E+00	0.00E+00	0.00E+00	0.00E+00
8	1.00E+00	-1.44E+00	1.40E-01	6.35E-02	0.00E+00	0.00E+00
9	9.73E-01	-3.32E+00	0.00E+00	0.00E+00	5.90E-02	1.32E-02
10	9.71E-01	-3.44E+00	0.00E+00	0.00E+00	1.80E-02	1.16E-02
11	9.69E-01	-3.55E+00	0.00E+00	0.00E+00	7.00E-03	3.60E-03
12	9.66E-01	-3.77E+00	0.00E+00	0.00E+00	1.22E-02	3.20E-03
13	9.66E-01	-3.76E+00	0.00E+00	0.00E+00	2.70E-02	1.16E-02
14	9.66E-01	-3.75E+00	0.00E+00	0.00E+00	2.98E-02	1.00E-02
15	9.91E-01	-1.67E+00	0.00E+00	0.00E+00	0.00E+00	0.00E+00
16	9.94E-01	-2.01E+00	8.00E-02	6.00E-02	0.00E+00	0.00E+00
TOTAL			5.27E-01	1.76E-01	5.18E-01	1.47E-01

MISMATCH = 2.15E-05

POWER FLOW LINE OUTPUT DATA FOR

LINE #	BUS TO	BUS	P	Q	S	RATING EXCEEDED
1	15	2	2.07E-01	2.07E-02	2.08E-01	
	2	15	-2.06E-01	-1.80E-02	2.07E-01	
2	15	5	9.63E-02	2.22E-02	9.88E-02	
	5	15	-9.58E-02	-2.00E-02	9.78E-02	
3	2	3	1.22E-01	3.20E-02	1.26E-01	
	3	2	-1.21E-01	-2.88E-02	1.24E-01	
4	2	4	6.92E-02	9.12E-03	6.98E-02	
	4	2	-6.89E-02	-8.24E-03	6.94E-02	
5	2	5	5.19E-02	1.05E-02	5.30E-02	
	5	2	-5.17E-02	-9.99E-03	5.27E-02	
6	3	4	-6.75E-02	-9.20E-03	6.81E-02	
	4	3	6.78E-02	1.00E-02	6.86E-02	
7	4	5	-7.52E-02	-4.76E-03	7.53E-02	
	5	4	7.53E-02	-4.51E-03	7.54E-02	
8	4	7	-2.97E-02	-8.51E-03	3.09E-02	
	7	4	2.97E-02	8.71E-03	3.10E-02	
9	4	9	1.04E-02	9.75E-03	1.42E-02	
	9	4	-1.03E-02	-9.63E-03	1.41E-02	
10	5	6	5.70E-02	3.13E-02	6.50E-02	
	6	5	-5.67E-02	-3.01E-02	6.42E-02	
11	6	11	-3.98E-03	4.65E-04	4.01E-03	
	11	6	3.98E-03	-4.61E-04	4.01E-03	
12	6	12	1.28E-02	4.33E-03	1.35E-02	

	12	6	-1.28E-02	-4.28E-03	1.35E-02
13	6	13	2.55E-02	1.04E-02	2.75E-02
	13	6	-2.54E-02	-1.03E-02	2.74E-02
14	7	8	-1.39E-01	-5.94E-02	1.51E-01
	8	7	1.40E-01	6.35E-02	1.54E-01
15	7	9	1.09E-01	5.06E-02	1.20E-01
	9	7	-1.09E-01	-4.90E-02	1.19E-01
16	9	10	2.90E-02	1.49E-02	3.26E-02
	10	9	-2.90E-02	-1.48E-02	3.25E-02
17	9	14	3.09E-02	1.06E-02	3.27E-02
	14	9	-3.08E-02	-1.03E-02	3.24E-02
18	10	11	1.10E-02	3.16E-03	1.14E-02
	11	10	-1.10E-02	-3.14E-03	1.14E-02
19	12	13	6.10E-04	1.08E-03	1.24E-03
	13	12	-6.09E-04	-1.08E-03	1.24E-03
20	13	14	-9.64E-04	-2.67E-04	1.00E-03
	14	13	9.64E-04	2.67E-04	1.00E-03
21	1	15	3.07E-01	5.24E-02	3.11E-01
	15	1	-3.04E-01	-4.28E-02	3.07E-01
22	2	16	-7.97E-02	-5.90E-02	9.92E-02
	16	2	8.00E-02	6.00E-02	1.00E-01

REMOVE Ctrl PRINT SCREEN AND THEN PRESS RETURN TO CONTINUE.

CASE STUDY 3 - TRIPLE LOAD WITH LOAD SHARING

22
 THE NUMBER OF LINES IS : 22
 1 15 2 .01938 .05917 0 0 5
 2 15 5 .05403 .22304 0 0 5
 3 2 3 .04699 .19797 0 0 5
 4 2 4 .05811 .17632 0 0 5
 5 2 5 .05695 .17388 0 0 5
 6 3 4 .06701 .17103 0 0 5
 7 4 5 .01335 .04211 0 0 5
 8 4 7 .0001 .20912 0 0 5
 9 4 9 .15 .55618 0 0 5
 10 5 6 .07 .25202 0 0 5
 11 6 11 .09498 .1989 0 0 5
 12 6 12 .12291 .25581 0 0 5
 13 6 13 .06615 .13027 0 0 5
 14 7 8 .05 .17615 0 0 5
 15 7 9 .03 .11001 0 0 5
 16 9 10 .03181 .0845 0 0 5
 17 9 14 .12711 .27038 0 0 5
 18 10 11 .08205 .19207 0 0 5
 19 12 13 .22092 .19988 0 0 5
 20 13 14 .17093 .34802 0 0 5
 21 1 15 .03 .1 0 0 5
 22 2 16 .03 .1 0 0 5

THE LARGEST BUS NUMBER IS 16
 1 0 1.005 0 0 0 0 0 0
 2 1 1 0 0 0 .0651 .0381 0 0 0
 3 1 1 0 0 0 .2826 .057 0 0 0
 4 1 1 0 0 0 .1434 -.0117 0 0 0
 5 1 1 0 0 0 .0228 .0048 0 0 0
 6 1 1 0 0 0 .0336 .0225 0 0 0
 7 1 1 0 0 0 0 0 0 0
 8 2 1 0 .21 0 0 0 .15 -.15
 9 1 1 0 0 0 .0885 .0498 0 0 0
 10 1 1 0 0 0 .027 .0174 0 0 0
 11 1 1 0 0 0 .0105 .0054 0 0 0
 12 1 1 0 0 0 .0183 .0048 0 0 0
 13 1 1 0 0 0 .0405 .0174 0 0 0
 14 1 1 0 0 0 .0447 .015 0 0 0
 15 1 1 0 0 0 0 0 0 0
 16 2 1 0 .12 0 0 0 .9 -.9

WARNING: YOUR TRANSFORMER DATA IS EMPTY.
 PLEASE CHECK YOUR TRANSFORMER INPUT DATA.
 PRESS RETURN TO CONTINUE.
 THE NUMBER OF TRANSFORMERS IS 0

THE TOLERANCE LEVEL IS .0001 .

DO YOU WANT TO CHANGE THE TOLERANCE LEVEL (Y OR N)? NN

THE MAXIMUM NUMBER OF ITERATIONS IS 20 .

DO YOU WANT TO CHANGE THE NUMBER OF ITERATIONS (Y OR N)? NN
 SELECTION OF INITIAL BUS VOLTAGE MAGNITUDES AND ANGLES :

1. FLAT START
2. OUTPUT VALUES FROM THE PREVIOUS RUN

ENTER YOUR SELECTION (1 OR 2) 11

STARTING VALUES

```

1.005 0
1.005 0
1.005 0
1.005 0
1.005 0
1.005 0
1.005 0
1.005 0
1 0
1.005 0
1.005 0
1.005 0
1.005 0
1.005 0
1.005 0
1.005 0
1 0

```

****THE PROGRAM IS RUNNING****

BUS ADMITTANCES MATRIX, REAL PARTS

2.752	0.000	0.000	0.000	0.000	0.000	0.000	0.000
0.000	0.000	0.000	0.000	0.000	0.000	-2.752	0.000
0.000	12.274	-1.135	-1.686	-1.701	0.000	0.000	0.000
0.000	0.000	0.000	0.000	0.000	0.000	-4.999	-2.752
0.000	-1.135	3.121	-1.986	0.000	0.000	0.000	0.000
0.000	0.000	0.000	0.000	0.000	0.000	0.000	0.000
0.000	-1.686	-1.986	10.967	-6.841	0.000	-0.002	0.000
-0.452	0.000	0.000	0.000	0.000	0.000	0.000	0.000
0.000	-1.701	0.000	-6.841	10.591	-1.023	0.000	0.000
0.000	0.000	0.000	0.000	0.000	0.000	-1.026	0.000
0.000	0.000	0.000	0.000	-1.023	7.603	0.000	0.000
0.000	0.000	-1.955	-1.526	-3.099	0.000	0.000	0.000
0.000	0.000	0.000	-0.002	0.000	0.000	3.801	-1.491
-2.307	0.000	0.000	0.000	0.000	0.000	0.000	0.000
0.000	0.000	0.000	0.000	0.000	0.000	-1.491	1.491
0.000	0.000	0.000	0.000	0.000	0.000	0.000	0.000
0.000	0.000	0.000	-0.452	0.000	0.000	-2.307	0.000
8.085	-3.902	0.000	0.000	0.000	-1.424	0.000	0.000

-14.768	4.403	0.000	0.000	0.000	0.000	0.000	0.000	0.000	0.000
0.000	0.000	0.000	0.000	0.000	4.094	0.000	0.000	0.000	0.000
4.403	-8.497	0.000	0.000	0.000	0.000	0.000	0.000	0.000	0.000
0.000	0.000	0.000	0.000	0.000	3.176	0.000	0.000	0.000	0.000
0.000	0.000	-5.428	2.252	0.000	0.000	0.000	0.000	0.000	0.000
0.000	0.000	0.000	0.000	0.000	6.103	0.000	0.000	0.000	0.000
0.000	0.000	2.252	-10.670	2.315	0.000	0.000	0.000	0.000	3.021
0.000	0.000	0.000	0.000	0.000	0.000	0.000	0.000	0.000	0.000
0.000	0.000	0.000	2.315	-5.344	0.000	0.000	0.000	0.000	0.000
9.174	15.263	0.000	0.000	4.235	0.000	0.000	0.000	0.000	0.000
0.000	0.000	0.000	0.000	0.000	-28.672	0.000	0.000	0.000	0.000
0.000	9.174	0.000	0.000	0.000	0.000	0.000	0.000	0.000	0.000
0.000	0.000	0.000	0.000	0.000	0.000	0.000	-9.174	0.000	0.000

***** PLEASE WAIT ... PROGRAM IS RUNNING *****

ITERATION # 1

***** PLEASE WAIT .. PROGRAM IS RUNNING *****
 THE NUMBER OF ROWS IN THE JACOBIAN MATRIX = 28

ITERATION # 1
 MISMATCH = 1.36E+00

ITERATION # 2

***** PLEASE WAIT .. PROGRAM IS RUNNING *****
 THE NUMBER OF ROWS IN THE JACOBIAN MATRIX = 28

DO YOU WANT TO DISPLAY THE LINE OUTPUT DATA (Y OR N) ? YY
 DO YOU WANT TO DISPLAY THE TRANSFORMER OUTPUT DATA (Y OR N) ? NN
 DO YOU WANT TO DISPLAY THE OUTPUT DATA IN EXPONENTIAL FORMAT (Y OR N) ? YY
 USE THE Ctrl PRINT SCREEN OPTION NOW IF YOU WANT TO PRINT THE RESULTS.
 PRESS RETURN TO CONTINUE.

POWER FLOW BUS OUTPUT DATA FOR

BUS#	VOLTAGE		GENERATION		LOAD	
	MAGNITUDE	PHASE ANGLE	PG	QG	PL	QL .95>V>1.05
	per unit	degrees	per unit	per unit	per unit	per unit
1	1.01E+00	0.00E+00	4.67E-01	4.74E-02	0.00E+00	0.00E+00
2	9.82E-01	-3.72E+00	0.00E+00	0.00E+00	6.51E-02	1.81E-02
3	9.63E-01	-5.77E+00	0.00E+00	0.00E+00	2.83E-01	5.70E-02
4	9.72E-01	-4.75E+00	0.00E+00	0.00E+00	1.43E-01	-1.17E-02
5	9.73E-01	-4.46E+00	0.00E+00	0.00E+00	2.28E-02	4.80E-03
6	9.54E-01	-5.59E+00	0.00E+00	0.00E+00	3.36E-02	2.25E-02
7	9.74E-01	-4.19E+00	0.00E+00	0.00E+00	0.00E+00	0.00E+00
8	1.00E+00	-2.29E+00	2.10E-01	9.27E-02	0.00E+00	0.00E+00
9	9.60E-01	-5.15E+00	0.00E+00	0.00E+00	8.85E-02	4.98E-02
10	9.57E-01	-5.34E+00	0.00E+00	0.00E+00	2.70E-02	1.74E-02
11	9.55E-01	-5.51E+00	0.00E+00	0.00E+00	1.05E-02	5.40E-03
12	9.50E-01	-5.85E+00	0.00E+00	0.00E+00	1.83E-02	4.80E-03
13	9.50E-01	-5.84E+00	0.00E+00	0.00E+00	4.05E-02	1.74E-02
14	9.50E-01	-5.81E+00	0.00E+00	0.00E+00	4.47E-02	1.50E-02
15	9.87E-01	-2.61E+00	0.00E+00	0.00E+00	0.00E+00	0.00E+00
16	1.00E+00	-3.28E+00	1.20E-01	1.48E-01	0.00E+00	0.00E+00
TOTAL			7.97E-01	2.88E-01	7.77E-01	2.21E-01

MISMATCH = 2.40E-05

POWER FLOW LINE OUTPUT DATA FOR

LINE #	BUS TO BUS		P	Q	S	RATING EXCEEDED
1	15	2	3.14E-01	-4.17E-03	3.14E-01	
	2	15	-3.12E-01	1.02E-02	3.13E-01	
2	15	5	1.46E-01	2.97E-02	1.49E-01	
	5	15	-1.45E-01	-2.47E-02	1.47E-01	

3	2	3	1.83E-01	5.31E-02	1.91E-01
	3	2	-1.81E-01	-4.57E-02	1.87E-01
4	2	4	1.05E-01	2.03E-02	1.06E-01
	4	2	-1.04E-01	-1.82E-02	1.05E-01
5	2	5	7.84E-02	2.26E-02	8.16E-02
	5	2	-7.80E-02	-2.14E-02	8.09E-02
6	3	4	-1.01E-01	-1.13E-02	1.02E-01
	4	3	1.02E-01	1.33E-02	1.03E-01
7	4	5	-1.13E-01	8.34E-03	1.14E-01
	5	4	1.13E-01	-7.77E-03	1.14E-01
8	4	7	-4.43E-02	-7.79E-03	4.50E-02
	7	4	4.43E-02	8.24E-03	4.51E-02
9	4	9	1.61E-02	1.61E-02	2.27E-02
	9	4	-1.60E-02	-1.58E-02	2.25E-02
10	5	6	8.65E-02	4.90E-02	9.94E-02
	6	5	-8.57E-02	-4.64E-02	9.75E-02
11	6	11	-5.66E-03	1.31E-03	5.81E-03
	11	6	5.66E-03	-1.30E-03	5.81E-03
12	6	12	1.93E-02	6.61E-03	2.04E-02
	12	6	-1.93E-02	-6.49E-03	2.03E-02
13	6	13	3.84E-02	1.60E-02	4.16E-02
	13	6	-3.83E-02	-1.57E-02	4.14E-02
14	7	8	-2.07E-01	-8.35E-02	2.24E-01
	8	7	2.10E-01	9.27E-02	2.30E-01
15	7	9	1.63E-01	7.52E-02	1.80E-01
	9	7	-1.62E-01	-7.15E-02	1.77E-01
16	9	10	4.33E-02	2.18E-02	4.84E-02
	10	9	-4.32E-02	-2.16E-02	4.83E-02
17	9	14	4.62E-02	1.57E-02	4.88E-02
	14	9	-4.59E-02	-1.50E-02	4.83E-02
18	10	11	1.62E-02	4.16E-03	1.67E-02
	11	10	-1.62E-02	-4.10E-03	1.67E-02
19	12	13	9.77E-04	1.69E-03	1.95E-03
	13	12	-9.76E-04	-1.69E-03	1.95E-03
20	13	14	-1.21E-03	7.70E-06	1.21E-03
	14	13	1.21E-03	-7.14E-06	1.21E-03
21	1	15	4.67E-01	4.74E-02	4.69E-01
	15	1	-4.60E-01	-2.56E-02	4.61E-01
22	2	16	-1.19E-01	-1.44E-01	1.87E-01
	16	2	1.20E-01	1.48E-01	1.90E-01

**CASE STUDY 4 - DOUBLE LOAD, ADDITIONAL LOAD SERVICED
BY SLACK BUS**

22
 THE NUMBER OF LINES IS : 22
 1 15 2 .01938 .05917 0 0 5
 2 15 5 .05403 .22304 0 0 5
 3 2 3 .04699 .19797 0 0 5
 4 2 4 .05811 .17632 0 0 5
 5 2 5 .05695 .17388 0 0 5
 6 3 4 .06701 .17103 0 0 5
 7 4 5 .01335 .04211 0 0 5
 8 4 7 .0001 .20912 0 0 5
 9 4 9 .15 .55618 0 0 5
 10 5 6 .07 .25202 0 0 5
 11 6 11 .09498 .1989 0 0 5
 12 6 12 .12291 .25581 0 0 5
 13 6 13 .06615 .13027 0 0 5
 14 7 8 .05 .17615 0 0 5
 15 7 9 .03 .11001 0 0 5
 16 9 10 .03181 .0845 0 0 5
 17 9 14 .12711 .27038 0 0 5
 18 10 11 .08205 .19207 0 0 5
 19 12 13 .22092 .19988 0 0 5
 20 13 14 .17093 .34802 0 0 5
 21 1 15 .03 .1 0 0 5
 22 2 16 .03 .1 0 0 5

THE LARGEST BUS NUMBER IS 16
 1 0 1.005 0 0 0 0 0 0
 2 1 1 0 0 0 .0434 .0254 0 0
 3 1 1 0 0 0 .1884 .038 0 0
 4 1 1 0 0 0 .0956 -.0078 0 0
 5 1 1 0 0 0 .0152 .0032 0 0
 6 1 1 0 0 0 .0224 .015 0 0
 7 1 1 0 0 0 0 0 0 0
 8 2 1 0 .07 0 0 .05 -.05
 9 1 1 0 0 0 .059 .0332 0 0
 10 1 1 0 0 0 .018 .0116 0 0
 11 1 1 0 0 0 .007 .0036 0 0
 12 1 1 0 0 0 .0122 .0032 0 0
 13 1 1 0 0 0 .027 .0116 0 0
 14 1 1 0 0 0 .0298 .01 0 0
 15 1 1 0 0 0 0 0 0 0
 16 2 1 0 .04 0 0 0 .03 -.03

WARNING: YOUR TRANSFORMER DATA IS EMPTY.
 PLEASE CHECK YOUR TRANSFORMER INPUT DATA.
 PRESS RETURN TO CONTINUE.
 THE NUMBER OF TRANSFORMERS IS 0

THE TOLERANCE LEVEL IS .0001 .

DO YOU WANT TO CHANGE THE TOLERANCE LEVEL (Y OR N)? NN

THE MAXIMUM NUMBER OF ITERATIONS IS 20 .

DO YOU WANT TO CHANGE THE NUMBER OF ITERATIONS (Y OR N)? NN
 SELECTION OF INITIAL BUS VOLTAGE MAGNITUDES AND ANGLES :

1. FLAT START
2. OUTPUT VALUES FROM THE PREVIOUS RUN

ENTER YOUR SELECTION (1 OR 2) 11

STARTING VALUES

1.005 0
 1.005 0
 1.005 0
 1.005 0
 1.005 0
 1.005 0
 1.005 0
 1.005 0
 1
 0
 1.005 0
 1.005 0
 1.005 0
 1.005 0
 1.005 0
 1.005 0
 1.005 0
 1
 0

****THE PROGRAM IS RUNNING****

BUS ADMITTANCES MATRIX, REAL PARTS

```

-----
  2.752   0.000   0.000   0.000   0.000   0.000   0.000   0.000
  0.000   0.000   0.000   0.000   0.000   0.000  -2.752   0.000
  0.000  12.274  -1.135  -1.686  -1.701   0.000   0.000   0.000
  0.000   0.000   0.000   0.000   0.000   0.000  -4.999  -2.752
  0.000  -1.135   3.121  -1.986   0.000   0.000   0.000   0.000
  0.000   0.000   0.000   0.000   0.000   0.000   0.000   0.000
  0.000  -1.686  -1.986  10.967  -6.841   0.000  -0.002   0.000
-0.452   0.000   0.000   0.000   0.000   0.000   0.000   0.000
  0.000  -1.701   0.000  -6.841  10.591  -1.023   0.000   0.000
  0.000   0.000   0.000   0.000   0.000   0.000  -1.026   0.000
  0.000   0.000   0.000   0.000  -1.023   7.603   0.000   0.000
  0.000   0.000  -1.955  -1.526  -3.099   0.000   0.000   0.000
  0.000   0.000   0.000  -0.002   0.000   0.000   3.801  -1.491
-2.307   0.000   0.000   0.000   0.000   0.000   0.000   0.000
  0.000   0.000   0.000   0.000   0.000   0.000  -1.491   1.491
  0.000   0.000   0.000   0.000   0.000   0.000   0.000   0.000
  0.000   0.000   0.000  -0.452   0.000   0.000  -2.307   0.000
  8.085  -3.902   0.000   0.000   0.000  -1.424   0.000   0.000

```

-14.768	4.403	0.000	0.000	0.000	0.000	0.000	0.000	0.000	0.000
0.000	0.000	0.000	0.000	0.000	4.094	0.000	0.000	0.000	0.000
4.403	-8.497	0.000	0.000	0.000	0.000	0.000	0.000	0.000	0.000
0.000	0.000	0.000	0.000	0.000	3.176	0.000	0.000	0.000	0.000
0.000	0.000	-5.428	2.252	0.000	0.000	0.000	0.000	0.000	0.000
0.000	0.000	0.000	0.000	0.000	6.103	0.000	0.000	0.000	0.000
0.000	0.000	2.252	-10.670	2.315	0.000	0.000	0.000	0.000	0.000
0.000	0.000	0.000	0.000	0.000	0.000	0.000	0.000	0.000	3.029
0.000	0.000	0.000	2.315	-5.344	0.000	0.000	0.000	0.000	0.000
9.174	15.263	0.000	0.000	4.235	0.000	0.000	0.000	0.000	0.000
0.000	0.000	0.000	0.000	0.000	-28.672	0.000	0.000	0.000	0.000
0.000	9.174	0.000	0.000	0.000	0.000	0.000	0.000	0.000	0.000
0.000	0.000	0.000	0.000	0.000	0.000	0.000	0.000	0.000	-9.174

***** PLEASE WAIT ... PROGRAM IS RUNNING *****

ITERATION # 1

***** PLEASE WAIT .. PROGRAM IS RUNNING *****
 THE NUMBER OF ROWS IN THE JACOBIAN MATRIX = 28

ITERATION # 1

MISMATCH = 8.32E-01

ITERATION # 2

***** PLEASE WAIT .. PROGRAM IS RUNNING *****
 THE NUMBER OF ROWS IN THE JACOBIAN MATRIX = 28

ENTER YOUR SELECTION (1,2,3 OR 4) 33

DO YOU WANT TO DISPLAY THE BUS OUTPUT DATA (Y OR N) ? YY

DO YOU WANT TO DISPLAY THE LINE OUTPUT DATA (Y OR N) ? YY

DO YOU WANT TO DISPLAY THE TRANSFORMER OUTPUT DATA (Y OR N) ? NN

DO YOU WANT TO DISPLAY THE OUTPUT DATA IN EXPONENTIAL FORMAT (Y OR N) ? YY
 USE THE Ctrl PRINT SCREEN OPTION NOW IF YOU WANT TO PRINT THE RESULTS.
 PRESS RETURN TO CONTINUE.

POWER FLOW BUS OUTPUT DATA FOR

BUS#	GENERATION				LOAD	
	VOLTAGE MAGNITUDE	PHASE ANGLE	PG	QG	PL	QL .95>V>1.05
	per unit	degrees	per unit	per unit	per unit	per unit
1	1.01E+00	0.00E+00	4.20E-01	1.07E-01	0.00E+00	0.00E+00
2	9.74E-01	-3.21E+00	0.00E+00	0.00E+00	4.34E-02	2.54E-02
3	9.61E-01	-4.69E+00	0.00E+00	0.00E+00	1.88E-01	3.80E-02
4	9.67E-01	-4.11E+00	0.00E+00	0.00E+00	9.56E-02	-7.80E-03
5	9.68E-01	-3.85E+00	0.00E+00	0.00E+00	1.52E-02	3.20E-03
6	9.55E-01	-4.81E+00	0.00E+00	0.00E+00	2.24E-02	1.50E-02
7	9.66E-01	-4.29E+00	0.00E+00	0.00E+00	0.00E+00	0.00E+00
8	9.79E-01	-3.70E+00	7.00E-02	5.00E-02	0.00E+00	0.00E+00
9	9.58E-01	-4.77E+00	0.00E+00	0.00E+00	5.90E-02	3.32E-02
10	9.56E-01	-4.85E+00	0.00E+00	0.00E+00	1.80E-02	1.16E-02
11	9.55E-01	-4.87E+00	0.00E+00	0.00E+00	7.00E-03	3.60E-03
12	9.52E-01	-5.01E+00	0.00E+00	0.00E+00	1.22E-02	3.20E-03
13	9.52E-01	-5.02E+00	0.00E+00	0.00E+00	2.70E-02	1.16E-02
14	9.51E-01	-5.12E+00	0.00E+00	0.00E+00	2.98E-02	1.00E-02
15	9.83E-01	-2.25E+00	0.00E+00	0.00E+00	0.00E+00	0.00E+00
16	9.78E-01	-3.02E+00	4.00E-02	3.00E-02	0.00E+00	0.00E+00
TOTAL			5.30E-01	1.87E-01	5.18E-01	1.47E-01

MISMATCH = 3.02E-05

POWER FLOW LINE OUTPUT DATA FOR

LINE #	BUS TO BUS	P	Q	S	RATING EXCEEDED
1	15 2	2.87E-01	5.48E-02	2.93E-01	

	2	15	-2.86E-01	-4.96E-02	2.90E-01
2	15	5	1.27E-01	3.38E-02	1.31E-01
	5	15	-1.26E-01	-2.98E-02	1.29E-01
3	2	3	1.31E-01	3.32E-02	1.35E-01
	3	2	-1.30E-01	-2.94E-02	1.33E-01
4	2	4	8.77E-02	1.08E-02	8.84E-02
	4	2	-8.73E-02	-9.32E-03	8.78E-02
5	2	5	6.38E-02	9.91E-03	6.46E-02
	5	2	-6.36E-02	-9.14E-03	6.42E-02
6	3	4	-5.87E-02	-8.56E-03	5.93E-02
	4	3	5.90E-02	9.21E-03	5.97E-02
7	4	5	-1.04E-01	-4.24E-03	1.04E-01
	5	4	1.04E-01	4.73E-03	1.04E-01
8	4	7	1.44E-02	2.44E-03	1.46E-02
	7	4	-1.44E-02	-2.39E-03	1.46E-02
9	4	9	2.18E-02	9.71E-03	2.39E-02
	9	4	-2.18E-02	-9.37E-03	2.37E-02
10	5	6	7.07E-02	3.10E-02	7.72E-02
	6	5	-7.02E-02	-2.94E-02	7.61E-02
11	6	11	4.22E-03	1.39E-04	4.22E-03
	11	6	-4.22E-03	-1.36E-04	4.22E-03
12	6	12	1.39E-02	4.10E-03	1.45E-02
	12	6	-1.39E-02	-4.04E-03	1.44E-02
13	6	13	2.97E-02	1.02E-02	3.14E-02
	13	6	-2.96E-02	-1.01E-02	3.13E-02
14	7	8	-6.96E-02	-4.86E-02	8.49E-02
	8	7	7.00E-02	5.00E-02	8.60E-02
15	7	9	8.40E-02	5.10E-02	9.83E-02
	9	7	-8.37E-02	-4.99E-02	9.74E-02
16	9	10	2.08E-02	1.51E-02	2.57E-02
	10	9	-2.08E-02	-1.51E-02	2.57E-02
17	9	14	2.56E-02	1.09E-02	2.78E-02
	14	9	-2.55E-02	-1.07E-02	2.77E-02
18	10	11	2.79E-03	3.47E-03	4.45E-03
	11	10	-2.79E-03	-3.46E-03	4.45E-03
19	12	13	1.67E-03	8.40E-04	1.87E-03
	13	12	-1.67E-03	-8.39E-04	1.86E-03
20	13	14	4.31E-03	-7.08E-04	4.37E-03
	14	13	-4.31E-03	7.15E-04	4.36E-03
21	1	15	4.20E-01	1.07E-01	4.33E-01

	15	1	-4.14E-01	-8.86E-02	4.24E-01
22	2	16	-3.99E-02	-2.97E-02	4.98E-02
	16	2	4.00E-02	3.00E-02	5.00E-02

REMOVE Ctrl PRINT SCREEN AND THEN PRESS RETURN TO CONTINUE.

**CASE STUDY 5 - TRIPLE LOAD, ADDITIONAL LOAD SERVICED
BY SLACK BUS**

```

22
THE NUMBER OF LINES IS : 22
1 15 2 .01938 .05917 0 0 5
2 15 5 .05403 .22304 0 0 5
3 2 3 .04699 .19797 0 0 5
4 2 4 .05811 .17632 0 0 5
5 2 5 .05695 .17388 0 0 5
6 3 4 .06701 .17103 0 0 5
7 4 5 .01335 .04211 0 0 5
8 4 7 .0001 .20912 0 0 5
9 4 9 .15 .55618 0 0 5
10 5 6 .07 .25202 0 0 5
11 6 11 .09498 .1989 0 0 5
12 6 12 .12291 .25581 0 0 5
13 6 13 .06615 .13027 0 0 5
14 7 8 .05 .17615 0 0 5
15 7 9 .03 .11001 0 0 5
16 9 10 .03181 .0845 0 0 5
17 9 14 .12711 .27038 0 0 5
18 10 11 .08205 .19207 0 0 5
19 12 13 .22092 .19988 0 0 5
20 13 14 .17093 .34802 0 0 5
21 1 15 .03 .1 0 0 5
22 2 16 .03 .1 0 0 5

```

```

THE LARGEST BUS NUMBER IS 16
1 0 1.005 0 0 0 0 0 0 0
2 1 1 0 0 0 .0651 .0381 0 0
3 1 1 0 0 0 .2826 .057 0 0
4 1 1 0 0 0 .1434 -.0117 0 0
5 1 1 0 0 0 .0228 .0048 0 0
6 1 1 0 0 0 .0336 .0225 0 0
7 1 1 0 0 0 0 0 0 0
8 2 1 0 .07 0 0 0 .05 -.05
9 1 1 0 0 0 .0885 .0498 0 0
10 1 1 0 0 0 .027 .0174 0 0
11 1 1 0 0 0 .0105 .0054 0 0
12 1 1 0 0 0 .0183 .0048 0 0
13 1 1 0 0 0 .0405 .0174 0 0
14 1 1 0 0 0 .0447 .015 0 0
15 1 1 0 0 0 0 0 0 0
16 2 1 0 .04 0 0 0 .03 -.03

```

```

WARNING: YOUR TRANSFORMER DATA IS EMPTY.
PLEASE CHECK YOUR TRANSFORMER INPUT DATA.
PRESS RETURN TO CONTINUE.
THE NUMBER OF TRANSFORMERS IS 0

```

THE TOLERANCE LEVEL IS .0001 .

DO YOU WANT TO CHANGE THE TOLERANCE LEVEL (Y OR N)? NN

THE MAXIMUM NUMBER OF ITERATIONS IS 20 .

DO YOU WANT TO CHANGE THE NUMBER OF ITERATIONS (Y OR N)? NN
SELECTION OF INITIAL BUS VOLTAGE MAGNITUDES AND ANGLES :

1. FLAT START
2. OUTPUT VALUES FROM THE PREVIOUS RUN

ENTER YOUR SELECTION (1 OR 2) 11

-14.768	4.403	0.000	0.000	0.000	0.000	0.000	0.000	0.000	0.000
0.000	0.000	0.000	0.000	0.000	4.094	0.000	0.000	0.000	0.000
4.403	-8.497	0.000	0.000	0.000	0.000	0.000	0.000	0.000	0.000
0.000	0.000	0.000	0.000	0.000	3.176	0.000	0.000	0.000	0.000
0.000	0.000	-5.428	2.252	0.000	0.000	0.000	0.000	0.000	0.000
0.000	0.000	0.000	0.000	0.000	6.103	0.000	0.000	0.000	0.000
0.000	0.000	2.252	-10.670	2.315	0.000	0.000	0.000	0.000	3.029
0.000	0.000	0.000	0.000	0.000	0.000	0.000	0.000	0.000	0.000
9.174	15.263	0.000	0.000	2.315	-5.344	0.000	0.000	0.000	0.000
0.000	0.000	0.000	0.000	0.000	0.000	-28.672	0.000	0.000	0.000
0.000	9.174	0.000	0.000	0.000	0.000	0.000	0.000	0.000	0.000
0.000	0.000	0.000	0.000	0.000	0.000	0.000	-9.174	0.000	0.000

***** PLEASE WAIT ... PROGRAM IS RUNNING *****

ITERATION # 1

***** PLEASE WAIT .. PROGRAM IS RUNNING *****
 THE NUMBER OF ROWS IN THE JACOBIAN MATRIX = 28

ITERATION # 1
 MISMATCH = 1.14E+00

ITERATION # 2

***** PLEASE WAIT .. PROGRAM IS RUNNING *****
 THE NUMBER OF ROWS IN THE JACOBIAN MATRIX = 28

DO YOU WANT TO DISPLAY THE TRANSFORMER OUTPUT DATA (Y OR N) ? NN

DO YOU WANT TO DISPLAY THE OUTPUT DATA IN EXPONENTIAL FORMAT (Y OR N) ? YY
 USE THE Ctrl PRINT SCREEN OPTION NOW IF YOU WANT TO PRINT THE RESULTS.
 PRESS RETURN TO CONTINUE.

POWER FLOW BUS OUTPUT DATA FOR

BUS#	VOLTAGE MAGNITUDE	PHASE ANGLE	GENERATION		LOAD		QL .95>V>1.05
			PG	QG	PL	per unit	
	per unit	degrees	per unit	per unit	per unit	per unit	
1	1.01E+00	0.00E+00	7.00E-01	2.53E-01	0.00E+00	0.00E+00	
2	9.44E-01	-5.31E+00	0.00E+00	0.00E+00	6.51E-02	1.81E-02	***
3	9.23E-01	-7.78E+00	0.00E+00	0.00E+00	2.83E-01	5.70E-02	***
4	9.31E-01	-6.87E+00	0.00E+00	0.00E+00	1.43E-01	-1.17E-02	***
5	9.34E-01	-6.41E+00	0.00E+00	0.00E+00	2.28E-02	4.80E-03	***
6	9.12E-01	-8.11E+00	0.00E+00	0.00E+00	1.36E-02	2.25E-02	***
7	9.26E-01	-7.46E+00	0.00E+00	0.00E+00	0.00E+00	0.00E+00	***
8	9.39E-01	-6.81E+00	7.00E-02	5.00E-02	0.00E+00	0.00E+00	***
9	9.14E-01	-8.15E+00	0.00E+00	0.00E+00	8.85E-02	4.98E-02	***
10	9.11E-01	-8.26E+00	0.00E+00	0.00E+00	2.70E-02	1.74E-02	***
11	9.10E-01	-8.24E+00	0.00E+00	0.00E+00	1.05E-02	5.40E-03	***
12	9.07E-01	-8.43E+00	0.00E+00	0.00E+00	1.83E-02	4.80E-03	***
13	9.06E-01	-8.46E+00	0.00E+00	0.00E+00	4.05E-02	1.74E-02	***
14	9.04E-01	-8.68E+00	0.00E+00	0.00E+00	4.47E-02	1.50E-02	***
15	9.61E-01	-3.71E+00	0.00E+00	0.00E+00	0.00E+00	0.00E+00	***
16	9.48E-01	-5.13E+00	4.00E-02	3.00E-02	0.00E+00	0.00E+00	***
		TOTAL	8.10E-01	3.33E-01	7.77E-01	2.21E-01	

MISMATCH = 1.54E-05

POWER FLOW LINE OUTPUT DATA FOR

LINE #	BUS TO BUS		P	Q	S	RATING EXCEEDED
1	15	2	4.76E-01	1.28E-01	4.93E-01	
	2	15	-4.71E-01	-1.12E-01	4.84E-01	
2	15	5	2.07E-01	7.05E-02	2.19E-01	
	5	15	-2.04E-01	-5.89E-02	2.13E-01	
3	2	3	2.01E-01	5.71E-02	2.09E-01	
	3	2	-1.99E-01	-4.74E-02	2.05E-01	

4	2	4	1.42E-01	2.56E-02	1.44E-01
	4	2	-1.41E-01	-2.15E-02	1.42E-01
5	2	5	1.03E-01	2.09E-02	1.05E-01
	5	2	-1.02E-01	-1.87E-02	1.04E-01
6	3	4	-8.36E-02	-9.61E-03	8.41E-02
	4	3	8.41E-02	1.10E-02	8.48E-02
7	4	5	-1.69E-01	-1.92E-02	1.70E-01
	5	4	1.69E-01	2.06E-02	1.71E-01
8	4	7	4.27E-02	2.29E-02	4.85E-02
	7	4	-4.27E-02	-2.24E-02	4.82E-02
9	4	9	3.93E-02	1.84E-02	4.34E-02
	9	4	-3.90E-02	-1.72E-02	4.26E-02
10	5	6	1.14E-01	5.23E-02	1.26E-01
	6	5	-1.13E-01	-4.77E-02	1.23E-01
11	6	11	1.09E-02	2.28E-03	1.11E-02
	11	6	-1.09E-02	-2.25E-03	1.11E-02
12	6	12	2.15E-02	6.38E-03	2.24E-02
	12	6	-2.14E-02	-6.22E-03	2.23E-02
13	6	13	4.70E-02	1.65E-02	4.98E-02
	13	6	-4.68E-02	-1.61E-02	4.95E-02
14	7	8	-6.96E-02	-4.85E-02	8.48E-02
	8	7	7.00E-02	5.00E-02	8.60E-02
15	7	9	1.12E-01	7.09E-02	1.33E-01
	9	7	-1.12E-01	-6.86E-02	1.31E-01
16	9	10	2.67E-02	2.07E-02	3.38E-02
	10	9	-2.66E-02	-2.06E-02	3.36E-02
17	9	14	3.55E-02	1.54E-02	3.87E-02
	14	9	-3.53E-02	-1.49E-02	3.83E-02
18	10	11	-3.63E-04	3.15E-03	3.17E-03
	11	10	3.64E-04	-3.15E-03	3.17E-03
19	12	13	3.15E-03	1.43E-03	3.45E-03
	13	12	-3.14E-03	-1.42E-03	3.45E-03
20	13	14	9.46E-03	1.68E-04	9.46E-03
	14	13	-9.44E-03	-1.30E-04	9.45E-03
21	1	15	7.00E-01	2.53E-01	7.44E-01
	15	1	-6.84E-01	-1.98E-01	7.12E-01
22	2	16	-3.99E-02	-2.97E-02	4.98E-02
	16	2	4.00E-02	3.00E-02	5.00E-02

REMOVE Ctrl PRINT SCREEN AND THEN PRESS RETURN TO CONTINUE.

APPENDIX C

**TABLES OF PARTICIPATION FACTORS, LINE AND LOAD
CONTRIBUTIONS**

TABLE C.1-A CASE STUDY 1
LINE PARTICIPATION FACTORS

	A	B	C	D	E	F	G	H	I	J
1	Line #	Bus-Bus	flow	Aikpg18	Aikpg8	atg16	atg8	dkr	dk16	dk8
2	1	15...2	0.103	-0.0077555	-0.00092	0.02576587	0.04509026	0.69935483	-0.138679	0.04206544
3	2	15...5	0.0477	0.00775442	0.00091987	0.01423325	0.02490818	0.29949097	0.13752023	-0.0431992
4	3	2...3	0.0606	0.00635628	-0.0007802	0.00526243	0.00920926	0.26626661	0.29361271	0.12356048
5	4	2...4	0.0343	0.01330192	-0.0016327	0.01101281	0.01927242	0.20274324	0.25997102	-0.065901
6	5	2...5	0.0258	0.01258591	0.001493	0.0094894	0.01660645	0.1448925	0.22230513	-0.0710139
7	6	3...4	-0.0338	0.00635586	-0.0007801	0.00526209	0.00920865	-0.0954215	-0.0680772	-0.2381182
8	7	4...5	-0.0371	-0.0037273	0.01300111	-0.0069286	-0.012125	-0.2506795	-0.1706485	0.10826486
9	8	4...7	-0.0156	0.01485965	-0.0185917	0.01474407	0.02580213	0.10587841	0.11276788	-0.5243194
10	9	4...9	0.00523	0.00852637	0.00317802	0.00846005	0.01480509	0.06433235	0.06599031	-0.1017685
11	10	5...8	0.0286	0.01661345	0.01541364	0.01679535	0.02939186	0.16383186	0.15928444	-0.035857
12	11	6...11	-0.00191	0.00327496	-0.0024933	0.00338845	0.00592979	0.02538924	0.02255212	-0.0949409
13	12	6...12	0.00644	0.00296558	0.00398138	0.00298167	0.00521792	0.02947368	0.02907141	0.01180862
14	13	6...13	0.0128	0.01037354	0.0139268	0.01042963	0.0182522	0.0658302	0.06442306	0.00403881
15	14	7...8	-0.0697	0	-0.0699998	0	0	0.00114847	0.00114847	-0.998848
16	15	7...9	0.0542	0.01485996	0.05140853	0.01474438	0.02580267	0.10911324	0.11200277	0.47491129
17	16	9...10	0.0144	0.00672518	0.01999504	0.00661564	0.01157737	0.02250109	0.02523954	0.14275363
18	17	9...14	0.0153	0.00666145	0.01709123	0.00658909	0.01153091	0.03703956	0.03884846	0.11647268
19	18	10...11	0.00541	-0.0032755	0.0024937	-0.0033809	-0.0059166	-0.0118992	-0.0052635	0.10824742
20	19	12...13	0.000332	0.00296546	0.00398123	0.00298155	0.00521772	0.0060712	0.00566894	-0.011593
21	20	13...14	-0.000412	0.00333886	0.00040921	0.00341122	0.00596964	0.02000301	0.01819409	-0.0594317
22	21	1...15	0.151	0	0	0.04	0.07	1	3.2863E-14	3.2863E-14
23	22	2...16	-0.0399	-0.04	0	0	0	0.00038314	-0.9996169	0.00038314
24										
25										
26										
27										
28		g1	0.151							
29		g16	0.04							
30		g8	0.07							
31		total	0.261							

TABLE C.1-B CASE STUDY 1
GENERATION CONTRIBUTION TO LINE FLOWS

	A	B	C	D	E	F	G	H	I
1	Line #	Bus-Bus	flow	g1cont	g16cont	g6cont	tot gen cont	dif	%dif
2	1	15_2	0.103	0.10560258	-0.009547161	0.002944581	0.103	1.3878E-17	1.347E-14
3	2	15...5	0.0477	0.045223136	0.005500809	-0.003023945	0.0477	6.9389E-18	1.455E-14
4	3	2...3	0.0606	0.040206258	0.011744508	0.008646234	0.0606	0	0
5	4	2...4	0.0343	0.030614229	0.010368841	-0.00671307	0.0343	6.9389E-18	2.023E-14
6	5	2...5	0.0258	0.021878788	0.008892205	-0.004670973	0.0258	6.9389E-18	2.689E-14
7	6	3...4	-0.0338	-0.014409541	-0.002723087	-0.016668273	-0.0338	0	0
8	7	4...5	-0.0371	-0.037852802	-0.006825839	0.00757854	-0.0371	-6.938E-18	1.87E-14
9	8	4...7	-0.0156	0.01859164	0.004510715	-0.036702365	-0.0156	6.9389E-18	-4.448E-14
10	9	4...9	0.00523	0.009714185	0.002639613	-0.007123798	0.00523	0	0
11	10	5...6	0.0286	0.004738611	0.006371378	-0.002506888	0.0286	0	0
12	11	6...11	-0.00191	0.003833776	0.000902085	-0.006645861	-0.00191	1.0842E-18	-5.676E-14
13	12	6...12	0.00644	0.004460526	0.001162856	0.000826818	0.00644	8.6736E-19	1.347E-14
14	13	6...13	0.0128	0.009940361	0.002578922	0.000282717	0.0128	1.7347E-18	1.366E-14
15	14	7...8	-0.0697	0.000173419	4.56389E-05	-0.069619368	-0.0697	0	0
16	15	7...9	0.0542	0.016478099	0.004480111	0.03324379	0.0542	6.9389E-18	1.28E-14
17	16	9...10	0.0144	0.003397664	0.001009582	0.009992754	0.0144	3.4694E-18	2.409E-14
18	17	9...14	0.0153	0.005592974	0.001553638	0.008153068	0.0153	1.7347E-18	1.134E-14
19	18	10...11	0.00541	-0.001796779	-0.00037054	0.00757732	0.00541	1.7347E-18	3.207E-14
20	19	12...13	0.000332	0.000916751	0.000226758	-0.000811509	0.000332	1.8974E-18	5.715E-13
21	20	13...14	-0.000412	0.000302495	0.000727783	-0.004160219	-0.000412	9.2157E-19	-2.237E-13
22	21	1...15	0.151	0.151	1.3145E-15	2.30038E-15	0.151	0	0
23	22	2...16	-0.0369	5.78544E-05	-0.03694674	2.68199E-05	-0.0369	6.9389E-18	-1.736E-14

TABLE C.1-C CASE STUDY 1
GENERATION CONTRIBUTION TO BUS LOAD

	A	B	C	D	E	F	G	H
1	Bus num	Installed Load	g1 cont	g16 cont	g6 cont	Total cont	Difference	% dif
2	1	0						
3	2	0.0217	0.01294547	0.003401959	0.00695257	0.0222	0.0005	2.304147465
4	3	0.0942	0.054614999	0.014467595	0.025317506	0.0944	0.0002	0.212314225
5	4	0.0478	0.027752365	0.007351365	0.01296627	0.04797	0.00017	0.355648536
6	5	0.0076	0.004510692	0.001195698	0.00205061	0.0078	0.0002	2.631578947
7	6	0.0112	0.006513948	0.001729514	0.003026338	0.01127	7E-05	0.625
8	7	0	-5.78785E-05	-1.53345E-05	-2.6787E-05	-0.0001	-0.0001	
9	8	0						
10	9	0.0295	0.017199646	0.004556204	0.007974151	0.02973	0.00023	0.779661017
11	10	0.009	0.005194443	0.001380122	0.002415434	0.00899	-1E-05	-0.111111111
12	11	0.0035	0.002036997	0.000531544	0.000931499	0.0035	-2.60209E-18	-7.43463E-14
13	12	0.0061	0.003533775	0.000936099	0.001638125	0.006108	8E-06	0.131147541
14	13	0.0135	0.007836657	0.002075917	0.003631427	0.013544	4.4E-05	0.325925926
15	14	0.0149	0.008613429	0.002281702	0.003992869	0.014888	-1.2E-05	-0.080536913
16	15	0	0.000174284	4.63515E-05	7.50647E-05	0.0003	0.0003	
17	16	0				0	0	
18	Total	0.259				0.2606		
19								
20	Calculated Total output		0.150768726	0.039908735	0.069892536	0.2606		
21								
22								
23	Actual Gen output		0.151	0.04	0.07			
24	difference		0.000231274	6.12546E-05	0.000107462			
25	% difference		0.153161494	0.153161494	0.153515494			

**TABLE C.2-A CASE STUDY 2
LINE PARTICIPATION FACTORS**

	A	B	C	D	E	F	G	H	I	J
1	Line #	Bus-Bus	flow	Alkpg16	Alkpg8	atg16	atg8	dlr	dlk16	dlk8
2	1	15..2	0.207	-0.015511	-0.00184	0.0515317	0.0901905	0.6946171	-0.1434167	0.0373277
3	2	15..5	0.0963	0.0155098	0.0018397	0.0284665	0.0468164	0.2963573	0.1363665	-0.0443329
4	3	2...3	0.122	0.0127126	-0.0015903	0.0105249	0.0184185	0.2652584	0.2929045	0.1225523
5	4	2...4	0.0992	0.0269038	-0.0032654	0.0220256	0.0385448	0.2019582	0.259186	-0.096686
6	5	2....5	0.0519	0.0251718	0.002598	0.0189798	0.0332129	0.1440871	0.2214997	-0.0718193
7	6	3...4	-0.0675	0.0127117	-0.0015602	0.0105242	0.0184173	-0.0943264	-0.0699621	-0.2370231
8	7	4...5	-0.0752	-0.0074547	0.0260022	-0.0138571	-0.02425	-0.2501987	-0.1701676	0.1087457
9	8	4....7	-0.0297	0.0297193	-0.0371834	0.0294881	0.0516043	0.1116822	0.1145717	-0.5225155
10	9	4...9	0.0104	0.0170527	0.006356	0.0165201	0.0296102	0.0636081	0.0652661	-0.1024928
11	10	5....6	0.057	0.0332269	0.0308273	0.0335907	0.0587837	0.161898	0.1573506	-0.0377909
12	11	6...11	-0.00398	0.0065499	-0.0049966	0.0067769	0.0118696	0.0248448	0.0220076	-0.0654854
13	12	6....12	0.0128	0.0059312	0.0079628	0.0059633	0.0104058	0.0290422	0.02864	0.0113774
14	13	6...13	0.0255	0.0207471	0.0278536	0.0208597	0.0369044	0.0650159	0.0639087	0.0032245
15	14	7...8	-0.139	0	-0.1399995	0	0	0.0018966	0.0018966	-0.9980996
16	15	7....9	0.109	0.0297199	0.1028171	0.0294888	0.0516053	0.1092165	0.1121061	0.4750146
17	16	9...10	0.029	0.0134504	0.0369901	0.0132313	0.0231547	0.0226571	0.0254056	0.1429197
18	17	9...14	0.0309	0.01332259	0.0341825	0.0131782	0.0230618	0.0372574	0.0390663	0.1166905
19	18	10...11	0.011	-0.0065509	0.0049874	-0.0067618	-0.0118331	-0.0114447	-0.0068061	0.1087019
20	19	12....13	0.00061	0.0069309	0.0079625	0.0059631	0.0104054	0.0059111	0.0055089	-0.0117531
21	20	13....14	-0.000964	0.0069777	0.0008184	0.0068224	0.0119393	0.0195478	0.0177386	-0.0598671
22	21	1...15	0.307	0	0	0	0.08	0.14	1	3.308E-14
23	22	2...16	-0.0797	-0.08	0	0	0	0.0005693	-0.9994307	0.0005693
24										
25										
26										
27										
28		g1	0.307							
29		g16	0.08							
30		g8	0.14							
31		total	0.527							

TABLE C.2-8 CASE STUDY 2
GENERATION CONTRIBUTION TO LINE FLOWS

	A	B	C	D	E	F	G	H	I
1	Line #	Bus-Bus	flow	g1cont	g1fcont	g6cont	tot gen cont	dif	%dif
2	1	15 2	0.207	0.213247456	-0.011473336	0.005225882	0.207	8.3267E-17	4.023E-14
3	2	15...5	0.0963	0.091966685	0.010910923	-0.006206607	0.0963	-1.368E-17	-1.441E-14
4	3	2...3	0.122	0.081434325	0.023408369	0.017157316	0.122	1.3878E-17	1.138E-14
5	4	2...4	0.0692	0.062001167	0.020734878	-0.013636046	0.0692	1.3878E-17	2.006E-14
6	5	2...5	0.0519	0.044234731	0.017719976	-0.010054707	0.0519	6.9389E-18	1.337E-14
7	6	3...4	-0.0675	-0.028968199	-0.005356567	-0.033183234	-0.0675	0	0
8	7	4...5	-0.0752	-0.076810966	-0.013613411	0.015224397	-0.0752	-1.368E-17	1.845E-14
9	8	4...7	-0.0297	0.034286441	0.009165735	-0.073152177	-0.0297	1.7347E-17	-5.841E-14
10	9	4...9	0.0104	0.019527868	0.005221288	-0.014349986	0.0104	-1.735E-18	-1.668E-14
11	10	5...6	0.057	0.046702677	0.012588044	-0.005290721	0.057	0	0
12	11	6...11	-0.00398	0.00762734	0.00178061	-0.01336795	-0.00398	2.6021E-18	-6.536E-14
13	12	6...12	0.0128	0.008915969	0.002291198	0.001592834	0.0128	1.7347E-18	1.365E-14
14	13	6...13	0.0255	0.019698874	0.005088998	0.000451428	0.0255	3.4994E-18	1.361E-14
15	14	7...8	-0.139	0.000582253	0.000151727	-0.13973398	-0.139	0	0
16	15	7...9	0.109	0.033529474	0.008968485	0.066502041	0.109	0	0
17	16	9...10	0.029	0.009588803	0.002032445	0.020008751	0.029	3.4994E-18	1.196E-14
18	17	9...14	0.0309	0.011438023	0.003125304	0.016339674	0.0309	1.0408E-17	3.368E-14
19	18	10...11	0.011	-0.003513538	-0.000704725	0.015218262	0.011	0	0
20	19	12...13	0.00061	0.001814717	0.00044071	-0.001645427	0.00061	4.6621E-18	7.643E-13
21	20	13...14	-0.000964	0.008001106	0.001419082	-0.008384198	-0.000964	4.3368E-19	-4.466E-14
22	21	1...15	0.307	0.307	2.64677E-15	4.63185E-15	0.307	0	0
23	22	2...16	-0.0797	0.000174763	-0.079654469	7.96964E-05	-0.0797	0	0

TABLE C.2-C CASE STUDY 2
GENERATION CONTRIBUTION TO BUS LOAD

	A	B	C	D	E	F	G	H
1	Bus num	Installed Load	g1 cont	g16 cont	g8 cont	Total cont	Difference	% dif
2	1	0						
3	2	0.0434	0.025402471	0.006617908	0.011579622	0.0436	0.0002	0.460829463
4	3	0.1884	0.110362524	0.028766926	0.05034055	0.1895	0.0011	0.583664119
5	4	0.0866	0.056039815	0.014802699	0.025557486	0.0962	0.0006	0.627615063
6	5	0.0152	0.009316753	0.002429444	0.004253803	0.016	0.0008	5.263157896
7	6	0.0224	0.013199464	0.003447538	0.006032968	0.0228	0.00028	1.25
8	7	0	0.000174714	4.55233E-05	7.97625E-05	0.0003	0.0003	
9	8	0						
10	9	0.059	0.034680345	0.009032024	0.015807631	0.0595	0.0005	0.847457627
11	10	0.018	0.010472341	0.00273717	0.004790489	0.018	0	0
12	11	0.007	0.004113802	0.001056885	0.001850313	0.00702	2E-05	0.285714286
13	12	0.0122	0.007101251	0.001850488	0.003236261	0.01219	-1E-05	-0.081967213
14	13	0.027	0.015773485	0.004110316	0.007190198	0.027074	7.4E-05	0.274074074
15	14	0.0298	0.017439129	0.004544396	0.007952475	0.029836	0.000136	0.456375839
16	15	0	0.002156859	0.000562415	0.000980726	0.0037	0.0037	
17	16	0				0	0	
18	Total	0.518				0.5257		
19								
20	Calculated Total output		0.306242964	0.079802732	0.139654284	0.5257		
21								
22								
23	Actual Gen output		0.307	0.08	0.14	0.527		
24	difference		0.000757016	0.000197268	0.000345716			
25	% difference		0.24658501	0.2465501	0.246940009			

**TABLE C.3-A CASE STUDY 3
LINE PARTICIPATION FACTORS**

	A	B	C	D	E	F	G	H	I	J
1	Line #	Bus-Bus	flow	Alkpg16	Alkpg6	a1g16	a1g6	dkr	dk16	dk6
2	1	15...2	0.314	-0.0232665	-0.00276	0.0772976	0.13527079	0.69334358	-0.1446903	0.03605419
3	2	15...5	0.146	0.02326325	0.0027596	0.04269074	0.07472454	0.29796879	0.13695905	-0.0448214
4	3	2...3	0.183	0.01906883	-0.0023405	0.0157873	0.02762778	0.26309505	0.29044115	0.12036892
5	4	2...4	0.105	0.03990577	-0.004698	0.03303943	0.05781726	0.20181676	0.25604454	-0.0968275
6	5	2...5	0.0784	0.03775772	0.004479	0.0284682	0.04661935	0.14360204	0.22101468	-0.0723044
7	6	3...4	-0.101	0.01906758	-0.0023404	0.01578626	0.02762596	-0.0932434	-0.0658991	-0.2359401
8	7	4...5	-0.113	-0.011182	0.03600333	-0.0207857	-0.036375	-0.2484091	-0.1683781	0.11053527
9	8	4...7	-0.0443	0.04467896	-0.0557751	0.04423222	0.07740638	0.11108506	0.11367454	-0.5231127
10	9	4...9	0.0161	0.0255791	0.0063407	0.02536015	0.04441526	0.06371673	0.06537469	-0.1023842
11	10	5...8	0.0685	0.04694035	0.04624091	0.05039604	0.08817557	0.1618323	0.15728468	-0.0378565
12	11	6...11	-0.00566	0.00682469	-0.00748	0.01016535	0.01778936	0.02503109	0.02219366	-0.036236
13	12	6...12	0.0193	0.00899673	0.01194414	0.00894601	0.01565376	0.02693086	0.02652958	0.011296
14	13	6...13	0.0384	0.03112063	0.04179041	0.03126949	0.05475661	0.06467364	0.06326989	0.00268245
15	14	7...8	-0.207	0	-0.2099993	0	0	0.00376318	0.00376318	-0.9962333
16	15	7...9	0.163	0.04467699	0.1542256	0.04423315	0.07740801	0.10769645	0.11058799	0.4734665
17	16	9...10	0.0433	0.02017553	0.05699513	0.01984691	0.0347321	0.02223131	0.0246976	0.14246365
18	17	9...14	0.0462	0.01998434	0.05127368	0.01976727	0.03469273	0.03676534	0.03857423	0.11619846
19	18	10...11	0.0162	-0.008264	0.00748111	-0.0101427	-0.0177497	-0.0117278	-0.0090921	0.1064188
20	19	12...13	0.000977	0.00899639	0.01194368	0.00894466	0.01565316	0.00594071	0.00653846	-0.0117235
21	20	13...14	-0.00121	0.01001659	0.00122762	0.01023367	0.01790991	0.01968427	0.01787534	-0.0597504
22	21	1...15	0.467	0	0	0	0.12	0.21	1	3.3418E-14
23	22	2...16	-0.119	-0.12	0	0	0	0.00125471	-0.9987463	0.00125471
24										
25										
26										
27										
28		g1	0.467							
29		g16	0.12							
30		g6	0.21							
31		total	0.797							

TABLE C.3-B CASE STUDY 3
GENERATION CONTRIBUTION TO LINE FLOWS

	A	B	C	D	E	F	G	H	I
1	Line #	Bus-Bus	flow	g1cont	g16cont	g6cont	tot gen cont	dif	%dif
2	1	15 2	0.314	0.323791453	-0.017362832	0.007571379	0.314	-1.11E-16	-3.536E-14
3	2	15...3	0.146	0.139104727	0.016307766	-0.009412463	0.146	-2.776E-17	-1.901E-14
4	3	2...3	0.183	0.122665369	0.034652536	0.025281673	0.183	0	0
5	4	2...4	0.105	0.094246426	0.031085345	-0.020333771	0.105	-4.163E-17	-3.965E-14
6	5	2...5	0.0784	0.067062156	0.029521761	-0.015183916	0.0784	-2.776E-17	-3.54E-14
7	6	3...4	-0.101	-0.043544676	-0.007907895	-0.046547429	-0.101	0	0
8	7	4...5	-0.113	-0.116007036	-0.020205367	0.023212406	-0.113	-1.368E-17	1.226E-14
9	8	4...7	-0.0443	0.051876724	0.013676944	-0.109653666	-0.0443	-6.939E-18	1.566E-14
10	9	4...9	0.0161	0.029755712	0.007844663	-0.021500674	0.0161	-1.041E-17	-6.465E-14
11	10	5...6	0.0665	0.075575685	0.018874186	-0.007946671	0.0665	-2.776E-17	-3.209E-14
12	11	6...11	-0.00566	0.011686619	0.0022663275	-0.020012794	-0.00566	-1.735E-18	3.065E-14
13	12	6...12	0.0193	0.013510711	0.00342343	0.002365659	0.0193	-3.469E-18	-1.798E-14
14	13	6...13	0.0364	0.030202683	0.007592003	0.000605314	0.0364	-2.062E-17	-5.421E-14
15	14	7...8	-0.207	0.001757405	0.000461582	-0.209209967	-0.207	0	0
16	15	7...9	0.163	0.050295176	0.013270598	0.099434266	0.163	2.7756E-17	1.703E-14
17	16	9...10	0.0433	0.010362021	0.002596371	0.025921608	0.0433	-6.939E-18	-1.603E-14
18	17	9...14	0.0462	0.017169415	0.004628908	0.024401677	0.0462	-6.939E-18	-1.502E-14
19	18	10...11	0.0162	-0.005476862	-0.001091056	0.022767946	0.0162	3.4694E-18	2.142E-14
20	19	12...13	0.000677	0.002774314	0.000664615	-0.002461926	0.000677	2.6021E-18	2.663E-13
21	20	13...14	-0.00212	0.009192552	0.002146041	-0.012547593	-0.00212	1.0942E-18	-8.95E-14
22	21	1...15	0.467	0.467	4.01013E-15	7.01772E-15	0.467	-5.561E-17	-1.166E-14
23	22	2...16	-0.119	0.000585947	-0.119849435	0.000253466	-0.119	1.3678E-17	-1.166E-14
24						0			

TABLE C.3-C CASE STUDY 3
GENERATION CONTRIBUTION TO BUS LOAD

	A	B	C	D	E	F	G	H
1	Bus num	Installed Load	g1 cont	g16 cont	g8 cont	Total cont	Difference	% dif
2	1	0						
3	2	0.0651	0.039029536	0.01002656	0.017543604	0.0666	0.0015	2.304147465
4	3	0.2826	0.166410065	0.042760833	0.074629102	0.284	0.0014	0.495399658
5	4	0.1434	0.095078363	0.02186091	0.038260737	0.1452	0.0018	1.255230126
6	5	0.0228	0.014584158	0.003746974	0.006565868	0.0249	0.0021	9.210526316
7	6	0.0336	0.020172773	0.005195477	0.00909175	0.0346	0.00066	2.55952381
8	7	0	-0.000175857	-4.51955E-05	-7.8947E-05	-0.0003	-0.0003	
9	8	0						
10	9	0.065	0.052499453	0.013490241	0.023610006	0.0896	0.0046	5.411754708
11	10	0.027	0.015858913	0.004067427	0.00715366	0.0271	0.0001	0.37037037
12	11	0.0105	0.006212627	0.001572219	0.002755154	0.01054	4E-05	0.390952381
13	12	0.0183	0.010796397	0.002758815	0.004827768	0.018323	2.3E-05	0.12568306
14	13	0.0405	0.023784444	0.006111577	0.010690978	0.040587	8.7E-05	0.214814815
15	14	0.0447	0.026361967	0.006773949	0.011854084	0.04499	0.00029	0.648789575
16	15	0	0.00410382	0.001055066	0.001841114	0.007	0.007	
17	16	0				0	0	
18	Total	0.7735				0.793		
19								
20	Calculated Total output		0.464656648	0.119397854	0.208945499	0.793		
21								
22								
23	Actual Gen output		0.467	0.12	0.21			
24	difference		0.002343652	0.000602146	0.001054501			
25	% difference		0.50178852	0.50178852	0.502140519			

**TABLE C.4-A CASE STUDY 4
LINE PARTICIPATION FACTORS**

	A	B	C	D	E	F	G	H	I	J
1	Line #	Bus-Bus	flow	Alkpg16	Alkpg8	a1g16	a1g8	dkr	dk16	dk8
2	1	15..2	0.287	-0.0077555	-0.00092	0.02576587	0.04500226	0.69156908	-0.1464648	0.03427668
3	2	15..5	0.127	0.00775442	0.00091987	0.01423325	0.02460818	0.29710782	0.13513707	-0.0465824
4	3	2...3	0.131	0.00635628	-0.0007802	0.00526243	0.00920926	0.26365363	0.29130003	0.12124781
5	4	2...4	0.0877	0.01330192	-0.0016327	0.01101281	0.01927242	0.2005962	0.25782388	-0.098048
6	5	2...5	0.0638	0.01258591	0.001463	0.0094894	0.01680945	0.14305084	0.22046347	-0.0728556
7	6	3...4	-0.0587	0.00635586	-0.0007901	0.00526209	0.00920965	-0.0939717	-0.0696274	-0.2366984
8	7	4...5	-0.104	-0.0037273	0.01300111	-0.0069286	-0.012125	-0.2496742	-0.1896432	0.10927011
9	8	4...7	0.0144	0.01485965	-0.0185917	0.01474407	0.02580213	0.11071371	0.11360318	-0.5234841
10	9	4...9	0.0218	0.00852637	0.00317802	0.00848005	0.01480909	0.0629448	0.06480276	-0.1031561
11	10	5...6	0.0707	0.01661345	0.01541364	0.01679535	0.02939186	0.16011342	0.15555601	-0.0396754
12	11	6...11	0.00422	0.00327486	-0.0024533	0.00338845	0.00562979	0.02406604	0.02123191	-0.0062511
13	12	6...12	0.0139	0.00296558	0.00398138	0.00298167	0.00521792	0.02858987	0.0281878	0.01092501
14	13	6...13	0.0297	0.01037354	0.0139298	0.01042983	0.0182522	0.06430508	0.06289792	0.00251367
15	14	7...8	-0.0896	0	-0.0699998	0	0	0.00075425	0.00075425	-0.9892422
16	15	7...9	0.084	0.01485966	0.05140853	0.01474408	0.02580267	0.10995564	0.11284907	0.47575759
17	16	9...10	0.0208	0.00672518	0.01996504	0.00661564	0.01157737	0.0231562	0.02589465	0.14040874
18	17	9...14	0.0256	0.00696145	0.01709123	0.00658909	0.01153091	0.0376742	0.03948309	0.11710732
19	18	10...11	0.00279	-0.0032755	0.0024637	-0.00338068	-0.0059166	-0.0108032	-0.0081675	0.10834343
20	19	12...13	0.00167	0.00296546	0.00398123	0.00298155	0.00521772	0.00651431	0.00511205	-0.0121489
21	20	13...14	0.00401	0.00333888	0.00040921	0.00341122	0.00599884	0.01875988	0.01685105	-0.0086747
22	21	1...15	0.42	0	0	0.04	0.07	1	4.4853E-14	4.4853E-14
23	22	2...16	-0.0399	-0.04	0	0	0	0.00018868	-0.9998113	0.00018868
24										0
25										
26										
27										
28		g1	0.42							
29		g16	0.04							
30		g8	0.07							
31		tot	0.53							

TABLE C.4-B CASE STUDY 4
GENERATION CONTRIBUTION TO LINE FLOWS

	A	B	C	D	E	F	G	H	I
1	Line #	Bus-Bus	flow	g1cont	g16cont	g6cont	tot gen cont	dif	%dif
2	1	15_2	0.287	0.290469013	-0.005668591	0.002369578	0.287	5.5511E-17	1.934E-14
3	2	15...5	0.127	0.124785283	0.005405483	-0.003190786	0.127	0	0
4	3	2...3	0.131	0.110660852	0.011652001	0.008487346	0.131	2.7756E-17	2.119E-14
5	4	2...4	0.0877	0.084250404	0.010312959	-0.008663363	0.0877	2.7756E-17	3.165E-14
6	5	2...5	0.0638	0.060061351	0.006818539	-0.00509989	0.0638	1.3878E-17	2.175E-14
7	6	3...4	-0.0587	-0.039498114	-0.002695096	-0.016566789	-0.0587	-1.388E-17	2.364E-14
8	7	4...5	-0.104	-0.104863179	-0.005785729	0.007648907	-0.104	-2.775E-17	2.689E-14
9	8	4...7	0.0144	0.048499757	0.004544127	-0.039643884	0.0144	1.0408E-17	7.228E-14
10	9	4...9	0.0218	0.025498816	0.00258411	-0.007220828	0.0218	0	0
11	10	5...6	0.0707	0.067247638	0.00622264	-0.002770279	0.0707	0	0
12	11	6...11	0.00422	0.010108998	0.000849277	-0.006736275	0.00422	2.6021E-18	6.166E-14
13	12	6...12	0.0139	0.012007745	0.001127504	0.000784751	0.0139	0	0
14	13	6...13	0.0297	0.027008126	0.002515917	0.000175957	0.0297	3.4694E-18	1.188E-14
15	14	7...8	-0.0696	0.000316784	3.01699E-05	-0.069946954	-0.0696	0	0
16	15	7...9	0.084	0.046183006	0.004513963	0.003003031	0.084	1.3878E-17	1.652E-14
17	16	9...10	0.0208	0.009725602	0.001035786	0.010038611	0.0208	0	0
18	17	9...14	0.0256	0.015823164	0.001579324	0.008197513	0.0256	3.4694E-18	1.355E-14
19	18	10...11	0.00279	-0.00463734	-0.0003267	0.00785404	0.00279	0	0
20	19	12...13	0.00167	0.0002316009	0.000204482	-0.000850491	0.00167	2.3852E-18	1.428E-13
21	20	13...14	0.00431	0.00787919	0.000678042	-0.004047231	0.00431	-8.674E-19	-2.012E-14
22	21	1...15	0.42	0.42	1.79412E-15	3.13971E-15	0.42	1.1102E-16	2.643E-14
23	22	2...16	-0.0369	7.92453E-05	-0.03692453	1.32075E-05	-0.0369	0	0

TABLE C.4-C CASE STUDY 4
GENERATION CONTRIBUTION TO BUS LOAD

	A	B	C	D	E	F	G	H
1	Bus num	Installed Load	g1 cont	g16 cont	g8 cont	Total cont	Difference	% dif
2	1	0						
3	2	0.0434	0.035187361	0.003360363	0.005662277	0.0444	0.001	2.304147465
4	3	0.1884	0.150328767	0.014317098	0.025054136	0.1897	0.0013	0.690021231
5	4	0.0956	0.076708895	0.007305354	0.012785751	0.0968	0.0012	1.255230126
6	5	0.0152	0.012756817	0.001215653	0.00212853	0.0161	0.0009	5.921052632
7	6	0.0224	0.018122768	0.001729943	0.003027269	0.02298	0.00048	2.142657143
8	7	0	-3.3037E-08	-5.56678E-09	3.86038E-08	-1.82146E-17	-1.82146E-17	
9	8	0						
10	9	0.069	0.047071055	0.004482954	0.007846981	0.0594	0.0004	0.677966102
11	10	0.018	0.014262943	0.001362486	0.002384671	0.01801	1E-05	0.056569566
12	11	0.007	0.006571668	0.000522576	0.000915765	0.00701	1E-05	0.142657143
13	12	0.0122	0.008991736	0.000623022	0.001615242	0.01223	3E-05	0.246901639
14	13	0.027	0.021444946	0.002042357	0.003572697	0.02706	6E-05	0.222222222
15	14	0.0298	0.023702353	0.002257368	0.003650281	0.02991	0.00011	0.369127517
16	15	0	0.004755704	0.000463108	0.000791188	0.006	0.006	
17	16	0				0	0	
18	Total	0.518				0.5295		
19								
20	Calculated Total output		0.419603971	0.036662283	0.066933747	0.5295		
21								
22								
23	Actual Gen output		0.42	0.04	0.07			
24	difference		0.000396029	3.77171E-05	6.62534E-05			
25	% difference		0.094292736	0.094292736	0.094647735			

TABLE C.5-A CASE STUDY 5
LINE PARTICIPATION FACTORS

	A	B	C	D	E	F	G	H	I	J
Line #	Bus-Bus	flow	Alkpg16	Alkpg8	alg16	atg8	dkr	dk16	dk8	
1										
2	1	15..2	0.476	-0.0077595	-0.00052	0.02576587	0.04509026	0.6868415	-0.1521924	0.0286521
3	2	15..5	0.207	0.00775442	0.00091987	0.01423325	0.02460818	0.29316631	0.13119657	-0.0465209
4	3	2...3	0.201	0.00635628	-0.0007802	0.00526243	0.00920926	0.25913035	0.28647645	0.11642422
5	4	2...4	0.142	0.01330192	-0.0016327	0.01101281	0.01927242	0.19629134	0.25551912	-0.1003529
6	5	2...5	0.103	0.01258591	0.001463	0.0094894	0.01660645	0.14196623	0.21940886	-0.0739102
7	6	3...4	-0.0536	0.00635586	-0.0007801	0.00526209	0.00920965	-0.0922294	-0.0648841	-0.2346251
8	7	4...5	-0.169	-0.0037273	0.01300111	-0.0069286	-0.012125	-2.43614	-0.163563	0.11533034
9	8	4...7	0.0427	0.01485995	-0.0185917	0.01474407	0.02580213	0.10739057	0.11027005	-0.5268172
10	9	4...9	0.0393	0.00852637	0.00317802	0.00846005	0.01490509	0.06279104	0.064449	-0.1033098
11	10	5...8	0.114	0.01681345	0.01541364	0.01679535	0.02939186	0.15822236	0.15367495	-0.0414695
12	11	6...11	0.0109	0.00327496	-0.0024933	0.00336846	0.00592979	0.02396679	0.02115866	-0.0963343
13	12	6...12	0.0215	0.00296558	0.00398138	0.00298167	0.00521752	0.02908967	0.02768739	0.01042481
14	13	6...13	0.047	0.01037354	0.0136268	0.01042983	0.01625222	0.06343418	0.06202703	0.00164276
15	14	7...8	-0.0696	0	-0.0695998	0	0	0.00049352	0.0049352	-0.9995029
16	15	7...9	0.112	0.01485996	0.05140653	0.01474438	0.02580267	0.10651673	0.10940627	0.47231479
17	16	9...10	0.0267	0.00672518	0.01959504	0.00661564	0.01157737	0.02243654	0.02517399	0.14268807
18	17	9...14	0.035	0.0066146	0.01709123	0.00558909	0.01153091	0.03687324	0.03668213	0.11630636
19	18	10...11	-0.000363	-0.0002795	0.0024937	-0.0033809	-0.0059166	-0.0109613	-0.0083257	0.10918527
20	19	12...13	0.00315	0.00296546	0.00398123	0.00298195	0.00521772	0.00543529	0.00503303	-0.0122289
21	20	13...14	0.00946	0.00333886	0.00040921	0.00341122	0.00596964	0.01863307	0.01682414	-0.0680816
22	21	1...15	0.7	0	0	0	0.07	1	4.9072E-14	4.9072E-14
23	22	2...16	-0.0399	-0.04	0	0	0	0.00012346	-0.9998765	0.00012346
24										
25										
26										
27										
28		g1		0.7						
29		g16		0.04						
30		g8		0.07						
31		total		0.81						

TABLE C.5-B CASE STUDY 5
GENERATION CONTRIBUTION TO LINE FLOWS

	A	B	C	D	E	F	G	H	I
1	Line #	Bus-Bus	flow	g1cont	g16cont	g6cont	tot gen cont	dif	%dif
2	1	15 2	0.476	0.480089047	-0.006087694	0.001968647	0.476	1.6653E-16	3.469E-14
3	2	15..5	0.207	0.205218519	0.005247943	-0.003466461	0.207	2.7756E-17	1.341E-14
4	3	2..3	0.201	0.181391246	0.011459058	0.008146696	0.201	5.5511E-17	2.762E-14
5	4	2...4	0.142	0.136803698	0.010220785	-0.007024703	0.142	5.5511E-17	3.909E-14
6	5	2...5	0.103	0.099397368	0.008776354	-0.005173713	0.103	1.3678E-17	1.347E-14
7	6	3...4	-0.0836	-0.054659878	-0.002556364	-0.016444758	-0.0836	-1.368E-17	1.66E-14
8	7	4...5	-0.169	-0.170529804	-0.00654332	0.008073123	-0.169	-2.776E-17	1.642E-14
9	8	4...7	0.0427	0.075166402	0.004410802	-0.036877204	0.0427	6.9389E-18	1.625E-14
10	9	4...9	0.0393	0.043663729	0.00257796	-0.007231689	0.0393	0	0
11	10	5...6	0.114	0.110756655	0.006146968	-0.002902653	0.114	1.3878E-17	1.217E-14
12	11	6...11	0.0109	0.016797056	0.000846347	-0.006743402	0.0109	1.7347E-18	1.591E-14
13	12	6...12	0.0215	0.019662788	0.001107466	0.000729737	0.0215	0	0
14	13	6...13	0.047	0.044403924	0.002481081	0.000114665	0.047	6.9389E-18	1.476E-14
15	14	7...8	-0.0696	0.000345464	1.97408E-05	-0.06965205	-0.0696	0	0
16	15	7...9	0.112	0.074661714	0.004376251	0.03062035	0.112	1.3878E-17	1.236E-14
17	16	9...10	0.0267	0.015704875	0.00100696	0.00698165	0.0267	3.4694E-18	1.259E-14
18	17	9...14	0.0365	0.025811269	0.001547285	0.008141445	0.0365	6.9389E-18	1.955E-14
19	18	10...11	-0.000363	-0.007672943	-0.000333026	0.007642689	-0.000363	-3.795E-19	1.045E-13
20	19	12...13	0.00315	0.003904701	0.000201321	-0.000856023	0.00315	1.7347E-18	5.507E-14
21	20	13...14	0.00946	0.013043149	0.000672966	-0.004256115	0.00946	3.4694E-18	3.667E-14
22	21	1...15	0.7	0.7	1.96287E-15	3.4303E-15	0.7	0	0
23	22	2...16	-0.0369	8.64198E-05	-0.036965062	8.64198E-06	-0.0369	0	0

TABLE C.5-C CASE STUDY 5
GENERATION CONTRIBUTION TO BUS LOAD

	A	B	C	D	E	F	G	H
1	Bus num	Installed Load	g1 cont	g16 cont	g8 cont	Total cont	Difference	% dif
2	1	0						
3	2	0.0651	0.060410085	0.003451191	0.006038725	0.0699	0.0048	7.373271889
4	3	0.2826	0.245951124	0.014054422	0.024594454	0.2946	0.002	0.707714084
5	4	0.1434	0.125653733	0.007179958	0.012566308	0.1454	0.002	1.394700139
6	5	0.0228	0.023330418	0.00133398	0.002335602	0.027	0.0042	18.42105263
7	6	0.0336	0.029891908	0.001712074	0.002996018	0.0346	0.001	2.976190476
8	7	0	0.000259223	1.48103E-05	2.59664E-05	0.0003	0.0003	
9	8	0						
10	9	0.0885	0.076999299	0.004399966	0.007700735	0.0891	0.0006	0.677966102
11	10	0.027	0.023377818	0.001339986	0.002345196	0.027063	6.3E-05	0.233333333
12	11	0.0105	0.009124113	0.00051332	0.000899567	0.010537	3.7E-05	0.352380952
13	12	0.0183	0.015858066	0.000905175	0.001585759	0.01835	5E-05	0.273224044
14	13	0.0405	0.035165476	0.002009437	0.003515087	0.04069	0.00019	0.469135822
15	14	0.0447	0.038854418	0.002220251	0.003885331	0.04496	0.00026	0.581655481
16	15	0	0.014692434	0.000639751	0.001467814	0.017	0.017	
17	16	0				0	0	
18	Total	0.777				0.8095		
19								
20	Calculated Total output		0.699568116	0.039975321	0.069956563	0.8095		
21								
22								
23	Actual Gen output		0.7	0.04	0.07			
24	difference		0.000431884	2.46791E-05	4.34369E-05			
25	% difference		0.061697718	0.061697718	0.062052715			

APPENDIX D

EXCEL CELL FORMULAS

TABLE D.1 EXCEL CELL FORMULAS
INVERSE ADMITTANCE MATRIX

	A	B	C	D	E
1	250.3226349	250.1845208	250.1584757	250.1359763	250.1432703
2	250.1845208	250.1959931	250.1645343	250.1373582	250.1412821
3	250.1584757	250.1645343	250.2438173	250.141279	250.1356411
4	250.1359763	250.1373582	250.141279	250.1446661	250.1307679
5	250.1432703	250.1412821	250.1356411	250.1307679	250.1507638
6	250.0374513	250.0366091	250.0342196	250.0321555	250.0406253
7	250.0588943	250.0596719	250.0618784	250.0637844	250.0559633
8	250.0588943	250.0596719	250.0618784	250.0637844	250.0559633
9	250.0183435	250.0188033	250.0201078	250.0212348	250.0166106
10	250.004368	250.0045964	250.0052444	250.0058041	250.0035072
11	250.0206022	250.0203243	250.01948	250.0187506	250.0217435
12	250.0183827	250.0176435	250.015546	250.0137341	250.021169
13	250.0034839	250.0028251	250.0009557	249.9993409	250.0059671
14	249.9738046	249.9737753	249.9736921	249.9736203	249.973915
15	250.2226349	250.1845208	250.1584757	250.1359763	250.1432703
16	250.1845208	250.1959931	250.1645343	250.1373582	250.1412821

**TABLE D.1 EXCEL CELL FORMULAS
INVERSE ADMITTANCE MATRIX**

	F	G	H	I	J
1	250.0374513	250.0588943	250.0588943	250.0183435	250.004368
2	250.0366091	250.0596719	250.0596719	250.0188033	250.0045964
3	250.0342196	250.0618784	250.0618784	250.0201078	250.0052444
4	250.0321555	250.0637844	250.0637844	250.0212348	250.0058041
5	250.0406253	250.0559633	250.0559633	250.0166106	250.0035072
6	250.1007218	250.0004698	250.0004698	249.9838008	249.98721
7	250.0004698	250.1193258	250.1193258	250.0385336	250.0143968
8	250.0004698	250.1193258	250.2954752	250.0385336	250.0143968
9	249.9838008	250.0385336	250.0385336	250.0476341	250.0189171
10	249.98721	250.0143968	250.0143968	250.0189171	250.0653908
11	250.0429787	250.0075544	250.0075544	250.0016644	250.0269803
12	250.0739221	249.9859201	249.9859201	249.971288	249.9721592
13	250.0529826	249.974552	249.974552	249.9615113	249.9603994
14	249.9760065	249.9725176	249.9725176	249.9719375	249.9552926
15	250.0374513	250.0588943	250.0588943	250.0183435	250.004368
16	250.0366091	250.0596719	250.0596719	250.0188033	250.0045964

**TABLE D.1 EXCEL CELL FORMULAS
INVERSE ADMITTANCE MATRIX**

	K	L	M	N	O
1	250.0206022	250.0183827	250.0034839	249.9738046	250.2226349
2	250.0203243	250.0176435	250.0028251	249.9737753	250.1845208
3	250.01948	250.015546	250.0009557	249.9736921	250.1584757
4	250.0187506	250.0137341	249.9993409	249.9736203	250.1359763
5	250.0217435	250.021169	250.0059671	249.973915	250.1432703
6	250.0429787	250.0739221	250.0529826	249.9760065	250.0374513
7	250.0075544	249.9859201	249.974552	249.9725176	250.0588943
8	250.0075544	249.9859201	249.974552	249.9725176	250.0588943
9	250.0016644	249.971288	249.9615113	249.9719375	250.0183435
10	250.0269803	249.9721592	249.9603994	249.9552926	250.004368
11	250.1325539	250.0221556	250.0058859	249.9654694	250.0206219
12	250.0221556	250.1878925	250.0770611	249.9794917	250.0183827
13	250.0058859	250.0770611	250.0958744	249.9822149	250.0034839
14	249.9654694	249.9794917	249.9822149	250.0905551	249.9738046
15	250.0206219	250.0183827	250.0034839	249.9738046	250.2226349
16	250.0203243	250.0176435	250.0028251	249.9737753	250.1845208

TABLE D.1 EXCEL CELL FORMULAS
INVERSE ADMITTANCE MATRIX

D-4

	P
1	250.1845208
2	250.1959931
3	250.1645343
4	250.1373582
5	250.1412821
6	250.0366091
7	250.0596719
8	250.0596719
9	250.0188033
10	250.0045964
11	250.0203243
12	250.0178435
13	250.0028251
14	249.9737753
15	250.1845208
16	250.2959931

TABLE D-2 EXCEL CELL FORMULAS
'A' FACTORS FOR TEST SYSTEM

	A	B	C	D
1	Line #	Bus-Bus	Reactance	Afacg1
2	1	15 2	0.05917	=((run.xls)yinv!O1-(run.xls)yinv!B1)/(run.xls)afac!\$C2
3	2	15...5	0.22304	=((run.xls)yinv!O1-(run.xls)yinv!E1)/(run.xls)afac!\$C3
4	3	2...3	0.19797	=((run.xls)yinv!B1-(run.xls)yinv!C1)/\$C4
5	4	2...4	0.17632	=((run.xls)yinv!B1-(run.xls)yinv!D1)/\$C5
6	5	2...5	0.17388	=((run.xls)yinv!B\$1-(run.xls)yinv!E\$1)/\$C6
7	6	3...4	0.17103	=((run.xls)yinv!C\$1-(run.xls)yinv!D\$1)/\$C7
8	7	4...5	0.04211	=((run.xls)yinv!D\$1-(run.xls)yinv!E\$1)/\$C8
9	8	4...7	0.20912	=((run.xls)yinv!D\$1-(run.xls)yinv!G\$1)/\$C9
10	9	4...9	0.55618	=((run.xls)yinv!D\$1-(run.xls)yinv!I\$1)/\$C10
11	10	5...6	0.25202	=((run.xls)yinv!E\$1-(run.xls)yinv!F\$1)/\$C11
12	11	6...11	0.1989	=((run.xls)yinv!F\$1-(run.xls)yinv!K\$1)/\$C12
13	12	6...12	0.25581	=((run.xls)yinv!F\$1-(run.xls)yinv!L\$1)/\$C13
14	13	6...13	0.13027	=((run.xls)yinv!F\$1-(run.xls)yinv!M\$1)/\$C14
15	14	7...8	0.17615	=((run.xls)yinv!G\$1-(run.xls)yinv!H\$1)/\$C15
16	15	7...9	0.11001	=((run.xls)yinv!G\$1-(run.xls)yinv!I\$1)/\$C16
17	16	9...10	0.0845	=((run.xls)yinv!I\$1-(run.xls)yinv!J\$1)/\$C17
18	17	9...14	0.27038	=((run.xls)yinv!I\$1-(run.xls)yinv!N\$1)/\$C18
19	18	10...11	0.19207	=((run.xls)yinv!J\$1-(run.xls)yinv!K\$1)/\$C19
20	19	12...13	0.19988	=((run.xls)yinv!L\$1-(run.xls)yinv!M\$1)/\$C20
21	20	13...14	0.34802	=((run.xls)yinv!M\$1-(run.xls)yinv!N\$1)/\$C21
22	21	1...15	0.1	=((run.xls)yinv!A\$1-(run.xls)yinv!O\$1)/\$C22
23	22	2...16	0.1	=((run.xls)yinv!B\$1-(run.xls)yinv!P\$1)/\$C23

TABLE D-2 EXCEL CELL FORMULAS
'A' FACTORS FOR TEST SYSTEM

	E
1	Afacg16
2	=((run.xls)Yinv!O16-(run.xls)Yinv!B16)/(run.xls)afac!\$C2
3	=((run.xls)Yinv!O16-(run.xls)Yinv!E16)/(run.xls)afac!\$C3
4	=((run.xls)Yinv!B16-(run.xls)Yinv!C16)/(run.xls)afac!\$C4
5	=((run.xls)Yinv!B16-(run.xls)Yinv!D16)/(run.xls)afac!\$C5
6	=((run.xls)Yinv!B16-(run.xls)Yinv!E16)/(run.xls)afac!\$C6
7	=((run.xls)Yinv!C16-(run.xls)Yinv!D16)/(run.xls)afac!\$C7
8	=((run.xls)Yinv!D\$16-(run.xls)Yinv!E\$16)/(run.xls)afac!\$C8
9	=((run.xls)Yinv!D\$16-(run.xls)Yinv!G\$16)/(run.xls)afac!\$C9
10	=((run.xls)Yinv!D\$16-(run.xls)Yinv!I\$16)/(run.xls)afac!\$C10
11	=((run.xls)Yinv!E\$16-(run.xls)Yinv!F\$16)/(run.xls)afac!\$C11
12	=((run.xls)Yinv!F\$16-(run.xls)Yinv!K\$16)/(run.xls)afac!\$C12
13	=((run.xls)Yinv!F\$16-(run.xls)Yinv!L\$16)/(run.xls)afac!\$C13
14	=((run.xls)Yinv!F\$16-(run.xls)Yinv!M\$16)/(run.xls)afac!\$C14
15	=((run.xls)Yinv!G\$16-(run.xls)Yinv!H\$16)/(run.xls)afac!\$C15
16	=((run.xls)Yinv!G\$16-(run.xls)Yinv!I\$16)/(run.xls)afac!\$C16
17	=((run.xls)Yinv!I\$16-(run.xls)Yinv!J\$16)/(run.xls)afac!\$C17
18	=((run.xls)Yinv!I\$16-(run.xls)Yinv!N\$16)/(run.xls)afac!\$C18
19	=((run.xls)Yinv!J\$16-(run.xls)Yinv!K\$16)/(run.xls)afac!\$C19
20	=((run.xls)Yinv!L\$16-(run.xls)Yinv!M\$16)/(run.xls)afac!\$C20
21	=((run.xls)Yinv!M\$16-(run.xls)Yinv!N\$16)/(run.xls)afac!\$C21
22	=((run.xls)Yinv!A\$16-(run.xls)Yinv!O\$16)/(run.xls)afac!\$C22
23	=((run.xls)Yinv!B\$16-(run.xls)Yinv!P\$16)/(run.xls)afac!\$C23

TABLE D-2 EXCEL CELL FORMULAS
'A' FACTORS FOR TEST SYSTEM

	F
1	Afacg8
2	$=([run.xls]yinv!O8-[run.xls]yinv!B8)/[run.xls]afac!$C2$
3	$=([run.xls]yinv!O8-[run.xls]yinv!E8)/[run.xls]afac!$C3$
4	$=([run.xls]yinv!B8-[run.xls]yinv!C8)/[run.xls]afac!$C4$
5	$=([run.xls]yinv!B8-[run.xls]yinv!D8)/[run.xls]afac!$C5$
6	$=([run.xls]yinv!B8-[run.xls]yinv!E8)/[run.xls]afac!$C6$
7	$=([run.xls]yinv!C8-[run.xls]yinv!D8)/[run.xls]afac!$C7$
8	$=([run.xls]yinv!D8-[run.xls]yinv!E8)/[run.xls]afac!$C8$
9	$=([run.xls]yinv!D8-[run.xls]yinv!G8)/[run.xls]afac!$C9$
10	$=([run.xls]yinv!D8-[run.xls]yinv!I8)/[run.xls]afac!$C10$
11	$=([run.xls]yinv!E8-[run.xls]yinv!F8)/[run.xls]afac!$C11$
12	$=([run.xls]yinv!F8-[run.xls]yinv!K8)/[run.xls]afac!$C12$
13	$=([run.xls]yinv!F8-[run.xls]yinv!L8)/[run.xls]afac!$C13$
14	$=([run.xls]yinv!F8-[run.xls]yinv!M8)/[run.xls]afac!$C14$
15	$=([run.xls]yinv!G8-[run.xls]yinv!H8)/[run.xls]afac!$C15$
16	$=([run.xls]yinv!G8-[run.xls]yinv!I8)/[run.xls]afac!$C16$
17	$=([run.xls]yinv!I8-[run.xls]yinv!J8)/[run.xls]afac!$C17$
18	$=([run.xls]yinv!I8-[run.xls]yinv!N8)/[run.xls]afac!$C18$
19	$=([run.xls]yinv!J8-[run.xls]yinv!K8)/[run.xls]afac!$C19$
20	$=([run.xls]yinv!L8-[run.xls]yinv!M8)/[run.xls]afac!$C20$
21	$=([run.xls]yinv!M8-[run.xls]yinv!N8)/[run.xls]afac!$C21$
22	$=([run.xls]yinv!A8-[run.xls]yinv!O8)/[run.xls]afac!$C22$
23	$=([run.xls]yinv!B8-[run.xls]yinv!P8)/[run.xls]afac!$C23$

TABLE D.3 EXCEL CELL FORMULAS
GENERATION PARTICIPATION FACTORS - TYPICAL

	A	B	C	D	E
1	Line #	Bus-Bus	flow	Alkpg16	Alkpg8
2	1	15...2	0.103	=SC\$29*[run.xls]afac!E2	=SC\$30*[run.xls]afac!F2
3	2	15...5	0.0477	=SC\$29*[run.xls]afac!E3	=SC\$30*[run.xls]afac!F3
4	3	2...3	0.0606	=SC\$29*[run.xls]afac!E4	=SC\$30*[run.xls]afac!F4
5	4	2...4	0.0343	=SC\$29*[run.xls]afac!E5	=SC\$30*[run.xls]afac!F5
6	5	2...5	0.0258	=SC\$29*[run.xls]afac!E6	=SC\$30*[run.xls]afac!F6
7	6	3...4	-0.0338	=SC\$29*[run.xls]afac!E7	=SC\$30*[run.xls]afac!F7
8	7	4...5	-0.0371	=SC\$29*[run.xls]afac!E8	=SC\$30*[run.xls]afac!F8
9	8	4...7	-0.0156	=SC\$29*[run.xls]afac!E9	=SC\$30*[run.xls]afac!F9
10	9	4...9	0.00523	=SC\$29*[run.xls]afac!E10	=SC\$30*[run.xls]afac!F10
11	10	5...6	0.0286	=SC\$29*[run.xls]afac!E11	=SC\$30*[run.xls]afac!F11
12	11	6...11	-0.00191	=SC\$29*[run.xls]afac!E12	=SC\$30*[run.xls]afac!F12
13	12	6...12	0.00644	=SC\$29*[run.xls]afac!E13	=SC\$30*[run.xls]afac!F13
14	13	6...13	0.0128	=SC\$29*[run.xls]afac!E14	=SC\$30*[run.xls]afac!F14
15	14	7...8	-0.0697	=SC\$29*[run.xls]afac!E15	=SC\$30*[run.xls]afac!F15
16	15	7...9	0.0542	=SC\$29*[run.xls]afac!E16	=SC\$30*[run.xls]afac!F16
17	16	9...10	0.0144	=SC\$29*[run.xls]afac!E17	=SC\$30*[run.xls]afac!F17
18	17	9...14	0.0153	=SC\$29*[run.xls]afac!E18	=SC\$30*[run.xls]afac!F18
19	18	10...11	0.00541	=SC\$29*[run.xls]afac!E19	=SC\$30*[run.xls]afac!F19
20	19	12...13	0.000332	=SC\$29*[run.xls]afac!E20	=SC\$30*[run.xls]afac!F20
21	20	13...14	-0.000412	=SC\$29*[run.xls]afac!E21	=SC\$30*[run.xls]afac!F21
22	21	1...15	0.151	=SC\$29*[run.xls]afac!E22	=SC\$30*[run.xls]afac!F22
23	22	2...16	-0.0399	=SC\$29*[run.xls]afac!E23	=SC\$30*[run.xls]afac!F23
24					
25					
26					
27					
28		g1	0.151		
29		g16	0.04		
30		g8	0.07		
31		total	=SUM(C28:		

TABLE D.3 EXCEL CELL FORMULAS
GENERATION PARTICIPATION FACTORS - TYPICAL

	F	G	H
1	a1g18	a1g8	dkr
2	=C\$29*(nun.xls)afacI02	=C\$30*(nun.xls)afacI02	=(C2-(D2+E2)+(F2+G2))/C\$31
3	=C\$29*(nun.xls)afacI03	=C\$30*(nun.xls)afacI03	=(C3-(D3+E3)+(F3+G3))/C\$31
4	=C\$29*(nun.xls)afacI04	=C\$30*(nun.xls)afacI04	=(C4-(D4+E4)+(F4+G4))/C\$31
5	=C\$29*(nun.xls)afacI05	=C\$30*(nun.xls)afacI05	=(C5-(D5+E5)+(F5+G5))/C\$31
6	=C\$29*(nun.xls)afacI06	=C\$30*(nun.xls)afacI06	=(C6-(D6+E6)+(F6+G6))/C\$31
7	=C\$29*(nun.xls)afacI07	=C\$30*(nun.xls)afacI07	=(C7-(D7+E7)+(F7+G7))/C\$31
8	=C\$29*(nun.xls)afacI08	=C\$30*(nun.xls)afacI08	=(C8-(D8+E8)+(F8+G8))/C\$31
9	=C\$29*(nun.xls)afacI09	=C\$30*(nun.xls)afacI09	=(C9-(D9+E9)+(F9+G9))/C\$31
10	=C\$29*(nun.xls)afacI10	=C\$30*(nun.xls)afacI10	=(C10-(D10+E10)+(F10+G10))/C\$31
11	=C\$29*(nun.xls)afacI11	=C\$30*(nun.xls)afacI11	=(C11-(D11+E11)+(F11+G11))/C\$31
12	=C\$29*(nun.xls)afacI12	=C\$30*(nun.xls)afacI12	=(C12-(D12+E12)+(F12+G12))/C\$31
13	=C\$29*(nun.xls)afacI13	=C\$30*(nun.xls)afacI13	=(C13-(D13+E13)+(F13+G13))/C\$31
14	=C\$29*(nun.xls)afacI14	=C\$30*(nun.xls)afacI14	=(C14-(D14+E14)+(F14+G14))/C\$31
15	=C\$29*(nun.xls)afacI15	=C\$30*(nun.xls)afacI15	=(C15-(D15+E15)+(F15+G15))/C\$31
16	=C\$29*(nun.xls)afacI16	=C\$30*(nun.xls)afacI16	=(C16-(D16+E16)+(F16+G16))/C\$31
17	=C\$29*(nun.xls)afacI17	=C\$30*(nun.xls)afacI17	=(C17-(D17+E17)+(F17+G17))/C\$31
18	=C\$29*(nun.xls)afacI18	=C\$30*(nun.xls)afacI18	=(C18-(D18+E18)+(F18+G18))/C\$31
19	=C\$29*(nun.xls)afacI19	=C\$30*(nun.xls)afacI19	=(C19-(D19+E19)+(F19+G19))/C\$31
20	=C\$29*(nun.xls)afacI20	=C\$30*(nun.xls)afacI20	=(C20-(D20+E20)+(F20+G20))/C\$31
21	=C\$29*(nun.xls)afacI21	=C\$30*(nun.xls)afacI21	=(C21-(D21+E21)+(F21+G21))/C\$31
22	=C\$29*(nun.xls)afacI22	=C\$30*(nun.xls)afacI22	=(C22-(D22+E22)+(F22+G22))/C\$31
23	=C\$29*(nun.xls)afacI23	=C\$30*(nun.xls)afacI23	=(C23-(D23+E23)+(F23+G23))/C\$31
24			
25			
26			
27			
28			
29			
30			
31			

TABLE D.3 EXCEL CELL FORMULAS
GENERATION PARTICIPATION FACTORS - TYPICAL

	I	J
1	dk16	dk8
2	=H2+{run.xls}\afac\E2-{run.xls}\afac\D2	=H2+{run.xls}\afac\F2-{run.xls}\afac\D2
3	=H3+{run.xls}\afac\E3-{run.xls}\afac\D3	=H3+{run.xls}\afac\F3-{run.xls}\afac\D3
4	=H4+{run.xls}\afac\E4-{run.xls}\afac\D4	=H4+{run.xls}\afac\F4-{run.xls}\afac\D4
5	=H5+{run.xls}\afac\E5-{run.xls}\afac\D5	=H5+{run.xls}\afac\F5-{run.xls}\afac\D5
6	=H6+{run.xls}\afac\E6-{run.xls}\afac\D6	=H6+{run.xls}\afac\F6-{run.xls}\afac\D6
7	=H7+{run.xls}\afac\E7-{run.xls}\afac\D7	=H7+{run.xls}\afac\F7-{run.xls}\afac\D7
8	=H8+{run.xls}\afac\E8-{run.xls}\afac\D8	=H8+{run.xls}\afac\F8-{run.xls}\afac\D8
9	=H9+{run.xls}\afac\E9-{run.xls}\afac\D9	=H9+{run.xls}\afac\F9-{run.xls}\afac\D9
10	=H10+{run.xls}\afac\E10-{run.xls}\afac\D10	=H10+{run.xls}\afac\F10-{run.xls}\afac\D10
11	=H11+{run.xls}\afac\E11-{run.xls}\afac\D11	=H11+{run.xls}\afac\F11-{run.xls}\afac\D11
12	=H12+{run.xls}\afac\E12-{run.xls}\afac\D12	=H12+{run.xls}\afac\F12-{run.xls}\afac\D12
13	=H13+{run.xls}\afac\E13-{run.xls}\afac\D13	=H13+{run.xls}\afac\F13-{run.xls}\afac\D13
14	=H14+{run.xls}\afac\E14-{run.xls}\afac\D14	=H14+{run.xls}\afac\F14-{run.xls}\afac\D14
15	=H15+{run.xls}\afac\E15-{run.xls}\afac\D15	=H15+{run.xls}\afac\F15-{run.xls}\afac\D15
16	=H16+{run.xls}\afac\E16-{run.xls}\afac\D16	=H16+{run.xls}\afac\F16-{run.xls}\afac\D16
17	=H17+{run.xls}\afac\E17-{run.xls}\afac\D17	=H17+{run.xls}\afac\F17-{run.xls}\afac\D17
18	=H18+{run.xls}\afac\E18-{run.xls}\afac\D18	=H18+{run.xls}\afac\F18-{run.xls}\afac\D18
19	=H19+{run.xls}\afac\E19-{run.xls}\afac\D19	=H19+{run.xls}\afac\F19-{run.xls}\afac\D19
20	=H20+{run.xls}\afac\E20-{run.xls}\afac\D20	=H20+{run.xls}\afac\F20-{run.xls}\afac\D20
21	=H21+{run.xls}\afac\E21-{run.xls}\afac\D21	=H21+{run.xls}\afac\F21-{run.xls}\afac\D21
22	=H22+{run.xls}\afac\E22-{run.xls}\afac\D22	=H22+{run.xls}\afac\F22-{run.xls}\afac\D22
23	=H23+{run.xls}\afac\E23-{run.xls}\afac\D23	=H23+{run.xls}\afac\F23-{run.xls}\afac\D23
24		
25		
26		
27		
28		
29		
30		
31		

TABLE D.4 EXCEL CELL FORMULAS
GENERATION CONTRIBUTION TO LINE FLOWS - TYPICAL

	A	B	C
1	Line #	Bus-Bus	flow
2	1	15 2	0.103
3	2	15...5	0.0477
4	3	2...3	0.0606
5	4	2...4	0.0343
6	5	2...5	0.0258
7	6	3...4	-0.0336
8	7	4...5	-0.0371
9	8	4...7	-0.0156
10	9	4...9	0.00523
11	10	5...6	0.0286
12	11	6...11	-0.00191
13	12	6...12	0.00544
14	13	6...13	0.0128
15	14	7...8	-0.0597
16	15	7...9	0.0542
17	16	9...10	0.0144
18	17	9...14	0.0153
19	18	10...11	0.00541
20	19	12...13	0.000332
21	20	13...14	-0.000412
22	21	1...15	0.151
23	22	2...16	-0.0399
24			

TABLE D 4 EXCEL CELL FORMULAS
 GENERATION CONTRIBUTION TO LINE FLOWS - TYPICAL

	D	E	F
1		g1cont	g1cont
2	=nunsdpart1!\$C\$28*(nunsdpart1!H2	=nunsdpart1!\$C\$29*(nunsdpart1!J2	=nunsdpart1!\$C\$30*(nunsdpart1!J2
3	=nunsdpart1!\$C\$28*(nunsdpart1!H3	=nunsdpart1!\$C\$29*(nunsdpart1!J3	=nunsdpart1!\$C\$30*(nunsdpart1!J3
4	=nunsdpart1!\$C\$28*(nunsdpart1!H4	=nunsdpart1!\$C\$29*(nunsdpart1!J4	=nunsdpart1!\$C\$30*(nunsdpart1!J4
5	=nunsdpart1!\$C\$28*(nunsdpart1!H5	=nunsdpart1!\$C\$29*(nunsdpart1!J5	=nunsdpart1!\$C\$30*(nunsdpart1!J5
6	=nunsdpart1!\$C\$28*(nunsdpart1!H6	=nunsdpart1!\$C\$29*(nunsdpart1!J6	=nunsdpart1!\$C\$30*(nunsdpart1!J6
7	=nunsdpart1!\$C\$28*(nunsdpart1!H7	=nunsdpart1!\$C\$29*(nunsdpart1!J7	=nunsdpart1!\$C\$30*(nunsdpart1!J7
8	=nunsdpart1!\$C\$28*(nunsdpart1!H8	=nunsdpart1!\$C\$29*(nunsdpart1!J8	=nunsdpart1!\$C\$30*(nunsdpart1!J8
9	=nunsdpart1!\$C\$28*(nunsdpart1!H9	=nunsdpart1!\$C\$29*(nunsdpart1!J9	=nunsdpart1!\$C\$30*(nunsdpart1!J9
10	=nunsdpart1!\$C\$28*(nunsdpart1!H10	=nunsdpart1!\$C\$29*(nunsdpart1!J10	=nunsdpart1!\$C\$30*(nunsdpart1!J10
11	=nunsdpart1!\$C\$28*(nunsdpart1!H11	=nunsdpart1!\$C\$29*(nunsdpart1!J11	=nunsdpart1!\$C\$30*(nunsdpart1!J11
12	=nunsdpart1!\$C\$28*(nunsdpart1!H12	=nunsdpart1!\$C\$29*(nunsdpart1!J12	=nunsdpart1!\$C\$30*(nunsdpart1!J12
13	=nunsdpart1!\$C\$28*(nunsdpart1!H13	=nunsdpart1!\$C\$29*(nunsdpart1!J13	=nunsdpart1!\$C\$30*(nunsdpart1!J13
14	=nunsdpart1!\$C\$28*(nunsdpart1!H14	=nunsdpart1!\$C\$29*(nunsdpart1!J14	=nunsdpart1!\$C\$30*(nunsdpart1!J14
15	=nunsdpart1!\$C\$28*(nunsdpart1!H15	=nunsdpart1!\$C\$29*(nunsdpart1!J15	=nunsdpart1!\$C\$30*(nunsdpart1!J15
16	=nunsdpart1!\$C\$28*(nunsdpart1!H16	=nunsdpart1!\$C\$29*(nunsdpart1!J16	=nunsdpart1!\$C\$30*(nunsdpart1!J16
17	=nunsdpart1!\$C\$28*(nunsdpart1!H17	=nunsdpart1!\$C\$29*(nunsdpart1!J17	=nunsdpart1!\$C\$30*(nunsdpart1!J17
18	=nunsdpart1!\$C\$28*(nunsdpart1!H18	=nunsdpart1!\$C\$29*(nunsdpart1!J18	=nunsdpart1!\$C\$30*(nunsdpart1!J18
19	=nunsdpart1!\$C\$28*(nunsdpart1!H19	=nunsdpart1!\$C\$29*(nunsdpart1!J19	=nunsdpart1!\$C\$30*(nunsdpart1!J19
20	=nunsdpart1!\$C\$28*(nunsdpart1!H20	=nunsdpart1!\$C\$29*(nunsdpart1!J20	=nunsdpart1!\$C\$30*(nunsdpart1!J20
21	=nunsdpart1!\$C\$28*(nunsdpart1!H21	=nunsdpart1!\$C\$29*(nunsdpart1!J21	=nunsdpart1!\$C\$30*(nunsdpart1!J21
22	=nunsdpart1!\$C\$28*(nunsdpart1!H22	=nunsdpart1!\$C\$29*(nunsdpart1!J22	=nunsdpart1!\$C\$30*(nunsdpart1!J22
23	=nunsdpart1!\$C\$28*(nunsdpart1!H23	=nunsdpart1!\$C\$29*(nunsdpart1!J23	=nunsdpart1!\$C\$30*(nunsdpart1!J23
24			

TABLE D.4 EXCEL CELL FORMULAS
GENERATION CONTRIBUTION TO LINE FLOWS - TYPICAL

	G	H	I
1	tot gen cont	dif	%dif
2	=SUM(D2:F2)	=C2-G2	=100*H2/C2
3	=SUM(D3:F3)	=C3-G3	=100*H3/C3
4	=SUM(D4:F4)	=C4-G4	=100*H4/C4
5	=SUM(D5:F5)	=C5-G5	=100*H5/C5
6	=SUM(D6:F6)	=C6-G6	=100*H6/C6
7	=SUM(D7:F7)	=C7-G7	=100*H7/C7
8	=SUM(D8:F8)	=C8-G8	=100*H8/C8
9	=SUM(D9:F9)	=C9-G9	=100*H9/C9
10	=SUM(D10:F10)	=C10-G10	=100*H10/C10
11	=SUM(D11:F11)	=C11-G11	=100*H11/C11
12	=SUM(D12:F12)	=C12-G12	=100*H12/C12
13	=SUM(D13:F13)	=C13-G13	=100*H13/C13
14	=SUM(D14:F14)	=C14-G14	=100*H14/C14
15	=SUM(D15:F15)	=C15-G15	=100*H15/C15
16	=SUM(D16:F16)	=C16-G16	=100*H16/C16
17	=SUM(D17:F17)	=C17-G17	=100*H17/C17
18	=SUM(D18:F18)	=C18-G18	=100*H18/C18
19	=SUM(D19:F19)	=C19-G19	=100*H19/C19
20	=SUM(D20:F20)	=C20-G20	=100*H20/C20
21	=SUM(D21:F21)	=C21-G21	=100*H21/C21
22	=SUM(D22:F22)	=C22-G22	=100*H22/C22
23	=SUM(D23:F23)	=C23-G23	=100*H23/C23
24			

TABLE D.5 EXCEL CELL FORMULAS
GENERATION CONTRIBUTION TO BUS LOAD - TYPICAL

	A	B	C
1	Bus num	Installed Load	g1 cont
2	1	0	
3	2	0.0217	=([run.xls]inet1!D2-[run.xls]inet1!D4-[run.xls]inet1!D5-[run.xls]inet1!D6-[run.xls]inet1!D23
4	3	0.0942	=([run.xls]inet1!D4-[run.xls]inet1!D7
5	4	0.0478	=([run.xls]inet1!D5+[run.xls]inet1!D7-[run.xls]inet1!D8-[run.xls]inet1!D9-[run.xls]inet1!D10
6	5	0.0076	=([run.xls]inet1!D3+[run.xls]inet1!D6-[run.xls]inet1!D8-[run.xls]inet1!D11
7	6	0.0112	=([run.xls]inet1!D11-[run.xls]inet1!D12-[run.xls]inet1!D13-[run.xls]inet1!D14
8	7	0	=([run.xls]inet1!D9-[run.xls]inet1!D15-[run.xls]inet1!D16
9	8	0	
10	9	0.0295	=([run.xls]inet1!D10+[run.xls]inet1!D16-[run.xls]inet1!D17-[run.xls]inet1!D18
11	10	0.009	=([run.xls]inet1!D17-[run.xls]inet1!D19
12	11	0.0035	=([run.xls]inet1!D12-[run.xls]inet1!D19
13	12	0.0061	=([run.xls]inet1!D13-[run.xls]inet1!D20
14	13	0.0135	=([run.xls]inet1!D14-[run.xls]inet1!D20-[run.xls]inet1!D21
15	14	0.0149	=([run.xls]inet1!D18+[run.xls]inet1!D21
16	15	0	=([run.xls]inet1!D22-[run.xls]inet1!D2-[run.xls]inet1!D3
17	16	0	
18	Total	=SUM(B2:B17)	
19			
20	Calculated Tc		=SUM(C2:C19)
21			
22			
23	Actual Gen α		0.151
24	difference		=C23-C20
25	% difference		=100*C24/C23
26			

TABLE D.5 EXCEL CELL FORMULAS
GENERATION CONTRIBUTION TO BUS LOAD - TYPICAL

	D
1	
2	g16 cont
3	= (run.xls)line1!E2 - (run.xls)line1!E4 - (run.xls)line1!E5 - (run.xls)line1!E6 - (run.xls)line1!E23
4	= (run.xls)line1!E4 - (run.xls)line1!E7
5	= (run.xls)line1!E5 + (run.xls)line1!E7 - (run.xls)line1!E8 - (run.xls)line1!E9 - (run.xls)line1!E10
6	= (run.xls)line1!E3 + (run.xls)line1!E9 + (run.xls)line1!E8 - (run.xls)line1!E11
7	= (run.xls)line1!E11 - (run.xls)line1!E12 - (run.xls)line1!E13 - (run.xls)line1!E14
8	= (run.xls)line1!E9 - (run.xls)line1!E15 - (run.xls)line1!E16
9	
10	= (run.xls)line1!E10 + (run.xls)line1!E16 - (run.xls)line1!E17 - (run.xls)line1!E18
11	= (run.xls)line1!E17 - (run.xls)line1!E19
12	= (run.xls)line1!E12 + (run.xls)line1!E19
13	= (run.xls)line1!E13 - (run.xls)line1!E20
14	= (run.xls)line1!E14 + (run.xls)line1!E20 - (run.xls)line1!E21
15	= (run.xls)line1!E18 + (run.xls)line1!E21
16	= (run.xls)line1!E22 - (run.xls)line1!E2 - (run.xls)line1!E3
17	
18	
19	
20	=SUM(D2:D19)
21	
22	
23	0.04
24	=D23-D20
25	=100*D24/D23
26	

TABLE D.5 EXCEL CELL FORMULAS
GENERATION CONTRIBUTION TO BUS LOAD - TYPICAL

	E
1	
2	g8 cont
3	= (run.xls) \inet1\F2 - (run.xls) \inet1\F4 - (run.xls) \inet1\F5 - (run.xls) \inet1\F6 - (run.xls) \inet1\F23
4	= (run.xls) \inet1\F4 - (run.xls) \inet1\F7
5	= (run.xls) \inet1\F5 + (run.xls) \inet1\F7 - (run.xls) \inet1\F8 - (run.xls) \inet1\F9 - (run.xls) \inet1\F10
6	= (run.xls) \inet1\F3 + (run.xls) \inet1\F6 + (run.xls) \inet1\F8 - (run.xls) \inet1\F11
7	= (run.xls) \inet1\F11 - (run.xls) \inet1\F12 - (run.xls) \inet1\F13 - (run.xls) \inet1\F14
8	= (run.xls) \inet1\F9 - (run.xls) \inet1\F15 - (run.xls) \inet1\F16
9	
10	= (run.xls) \inet1\F10 + (run.xls) \inet1\F16 - (run.xls) \inet1\F17 - (run.xls) \inet1\F18
11	= (run.xls) \inet1\F17 - (run.xls) \inet1\F19
12	= (run.xls) \inet1\F12 + (run.xls) \inet1\F19
13	= (run.xls) \inet1\F13 - (run.xls) \inet1\F20
14	= (run.xls) \inet1\F14 + (run.xls) \inet1\F20 - (run.xls) \inet1\F21
15	= (run.xls) \inet1\F18 + (run.xls) \inet1\F21
16	= (run.xls) \inet1\F22 - (run.xls) \inet1\F2 - (run.xls) \inet1\F3
17	
18	
19	
20	=SUM(E2:E19)
21	
22	
23	0.07
24	=E23-E20
25	=100*E24/E23
26	

TABLE D.5 EXCEL CELL FORMULAS
GENERATION CONTRIBUTION TO BUS LOAD - TYPICAL

	F	G	H
1	Total cont	Difference	% diff
2			
3	=SUM(C3:E3)	=F3-B3	=100*G3/B3
4	=SUM(C4:E4)	=F4-B4	=100*G4/B4
5	=SUM(C5:E5)	=F5-B5	=100*G5/B5
6	=SUM(C6:E6)	=F6-B6	=100*G6/B6
7	=SUM(C7:E7)	=F7-B7	=100*G7/B7
8	=SUM(C8:E8)	=F8-B8	
9			
10	=SUM(C10:E10)	=F10-B10	=100*G10/B10
11	=SUM(C11:E11)	=F11-B11	=100*G11/B11
12	=SUM(C12:E12)	=F12-B12	=100*G12/B12
13	=SUM(C13:E13)	=F13-B13	=100*G13/B13
14	=SUM(C14:E14)	=F14-B14	=100*G14/B14
15	=SUM(C15:E15)	=F15-B15	=100*G15/B15
16	=SUM(C16:E16)	=F16-B16	
17	=SUM(C17:E17)	=F17-B17	
18	=SUM(F2:F17)		
19			
20	=SUM(C20:E20)		
21			
22			
23			
24			
25			
26			



